



This is a digital copy of a book that was preserved for generations on library shelves before it was carefully scanned by Google as part of a project to make the world's books discoverable online.

It has survived long enough for the copyright to expire and the book to enter the public domain. A public domain book is one that was never subject to copyright or whose legal copyright term has expired. Whether a book is in the public domain may vary country to country. Public domain books are our gateways to the past, representing a wealth of history, culture and knowledge that's often difficult to discover.

Marks, notations and other marginalia present in the original volume will appear in this file - a reminder of this book's long journey from the publisher to a library and finally to you.

Usage guidelines

Google is proud to partner with libraries to digitize public domain materials and make them widely accessible. Public domain books belong to the public and we are merely their custodians. Nevertheless, this work is expensive, so in order to keep providing this resource, we have taken steps to prevent abuse by commercial parties, including placing technical restrictions on automated querying.

We also ask that you:

- + *Make non-commercial use of the files* We designed Google Book Search for use by individuals, and we request that you use these files for personal, non-commercial purposes.
- + *Refrain from automated querying* Do not send automated queries of any sort to Google's system: If you are conducting research on machine translation, optical character recognition or other areas where access to a large amount of text is helpful, please contact us. We encourage the use of public domain materials for these purposes and may be able to help.
- + *Maintain attribution* The Google "watermark" you see on each file is essential for informing people about this project and helping them find additional materials through Google Book Search. Please do not remove it.
- + *Keep it legal* Whatever your use, remember that you are responsible for ensuring that what you are doing is legal. Do not assume that just because we believe a book is in the public domain for users in the United States, that the work is also in the public domain for users in other countries. Whether a book is still in copyright varies from country to country, and we can't offer guidance on whether any specific use of any specific book is allowed. Please do not assume that a book's appearance in Google Book Search means it can be used in any manner anywhere in the world. Copyright infringement liability can be quite severe.

About Google Book Search

Google's mission is to organize the world's information and to make it universally accessible and useful. Google Book Search helps readers discover the world's books while helping authors and publishers reach new audiences. You can search through the full text of this book on the web at <http://books.google.com/>



The Philatelic gazette



Philately
TVG

7 26 1915

THE PHILATELIC GAZETTE

VOLUME V

January, 1915

To December, 1915

PUBLISHED BY
NASSAU STAMP CO.
118 NASSAU STREET
NEW YORK

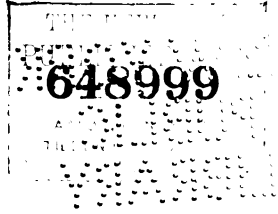

INDEX TO CONTENTS VOLUME V THE PHILATELIC GAZETTE

A

Advertisers,
 Bartels, J. M., Co.
 Belgian Relief Committee
 Brown, F. P.
 Clarke Stamp Co.
 Collectors Journal
 Dietrich, C. G.
 Economist Stamp Co.
 Empire Stamp Co. of Pennsylvania
 Everybody's Philatelist
 Houtzamer, W.
 Klein, Eugene
 Klemann, J. A.
 Kurth, Alfred
 Morgenthau, J. C.
 Mozian, Vahan
 Nassau Stamp Co.
 New England Philatelist
 Philatelic West
 Scott Stamp & Coin Co.
 Szekula, Bela
 Tuttle, G. R.
 Voorhees, B. L.
 Aeroplane Mail Service Data, 145,
 167.
 American Philatelic Society, 149,
 171, 201, 225.
 Argentine, 20p. 1891, Falsification
 of, 60.
 Association for Stamp Exhibitions,
 64.
 Auction Reports, 38, 61, 86, 112,
 148, 174, 278.
 Austria, The Postal Issues of, 5, 26,
 75, 100, 125, 163, 196, 209, 263.

B

Bagg, Egbert, 191.
 Bartels, J. M., 53, 58, 137, 187, 223,
 254, 263, 279, 299.
 Belgian Relief Committee, 226.
 Belgium, Line Engraved Stamps, 235,
 266, 293.
 Berthold, V. M., 132.
 Bolivar, Stamps of 1879-1889, 49, 95,
 140, 159, 180, 213, 239, 300.
 British North Borneo, 2c of 1883,
 188, 224, 238.
 Bulgaria, 261, 304.
 Bureau of Engraving & Printing, ex-
 tract Annual Report, 15.

C

Cancellations, Wesson Device, 275.
 Chase, Carroll, 13, 30, 73, 143.
 Chittenden, Dr. J. B., 5, 26, 75, 100,
 125, 163, 196, 209, 263.
 Chronicle, U. S. Envelopes, 35, 81,
 187, 223, 254, 263, 299.
 Collectors Club, 63, 89, 114.
 Communications, 37, 89.
 Confederate States of America, His-
 tory of the General Issues, 153,
 192, 231, 272, 289.

D

Die Proofs, U. S., 120, 269.
 Dole, W. H., 109, 136.
E
 Editorial, 14, 34, 54, 82, 104, 138,
 166, 190, 216, 244, 270, 298.
 Envelope, U. S.
 Chronicle, 35, 81, 137, 187, 223,
 254, 263, 299.
 Date of Issue, 132.

G

Garfield Perry Stamp Club, 55, 65,
 87.
 Government Collection of Postage
 Stamps, The U. S., 1, 21, 41, 69,
 177, 257.

H

Hatfield, A., Jr., 49, 95, 140, 159,
 180, 213, 239, 300.
 Hobby of Stamp Collecting, 139.
 Howes, C. A., 261, 304.

I

Ingram, Derek, 235, 266.
 International Society of Postage
 Stamp Dealers, Paris, 173, 201,
 293.

K

Kansas City Roulette, 25, 51.
 Kansas City Philatelic Society, 66.
 Klemann, J., Jr., 275.

L

Leavy, J. B., 1, 21, 41, 69, 93, 120, 177, 205, 229, 257, 285.
 Legg, Harry Wesley, 191.
 Locals, U. S., A Concise History, 84, 107, 131, 169, 245, 296.
 Loescher, W., 60.

M

Morgenthau, J. C., 38, 61, 86, 148, 174, 278.
 Museum Collection, 1, 21, 41, 69, 93, 177, 205, 229, 257, 285.

N

Nassau Stamp Co., 149.
 National Philatelic Society, 149, 173, 201.
 National Philatelic War Fund, 281, 308.
 Necrology, 191.
 Needham, H. C., 84, 107, 131, 169, 245, 296.
 New Issues, 17, 31, 47, 79, 106, 128, 198, 223, 251, 279, 307.
 New South Wales, 2p. 1853, 72, 132, 167.
 New York Philatelic Exchange Society, 150.
 New York Stamp Society, 66, 88, 150.

O

Owen, A. E., 13, 30, 73, 143.

P

Pacific Philatelic Society, 87, 150.
 Pack, Charles Lathrop, 72, 132, 139.
 Philadelphia Stamp Club, 114, 151.
 Plate Numbers, 11, 80, 170, 222, 269.
 Poole, B. W. H., 32, 49, 95, 140, 153, 159, 180, 188, 192, 213, 224, 231, 238, 239, 272, 289, 300.

R

Review, 66, 90, 115, 283, 311.
 Rhode Island Philatelic Society, 151.
 Rotary Webb Printing Press, 15.

S

Short Notes & News, 15, 35, 105, 145, 167, 217, 271, 299.
 Sprague, W. B., 13, 30, 73, 143.
 Society Notes, 38, 63, 87, 171, 201, 225.
 Southern Philatelic Society, 203.
 Staten Island Stamp Society, 66.
 Stewart, Melville, 191.

T

Texas Philatelic Society, 226.

U

United States
 1851 Issue, 53.
 1890 Issue, 105.
 A detailed History 1847-1890, 13, 30, 73, 143.
 Aeroplane Mail Service Data, 145, 167.
 Coils & Imperforates, 105.
 Confederate States of America, History of the General Issues, 153, 192, 231, 272, 289.
 Die Proofs, 120, 269.
 Envelopes,
 Chronicle, 35, 81, 137, 187, 223, 254, 263, 299.
 Discovery, Date of Issue, 132.
 Experimental Paper, 33.
 Government Collection, 1, 21, 41, 69, 93, 177, 205, 229, 257, 285.
 Kansas City Roulette, 25, 51.
 Locals, A Concise History and Memoranda, 84, 107, 131, 169, 245, 296.
 New Discovery
 on 10c 1898, 32.
 on \$1.00 1894, 5, 46.
 One cent green 1910, 36.
 Plate Numbers, 11, 80, 170, 222, 269.
 Postage Stamps, Number Issued 1914, 15.
 Postal Savings, 271.
 Stamp book, check list, 109, 136.
 Universal Postal Union, 217.

W

Ward, P. H., Jr., 36, 221.
 Washington Notes, 58, 221.
 Washington State Philatelic Society, 88, 149.

THE PHILATELIC GAZETTE

PUBLISHED MONTHLY FOR STAMP COLLECTORS

VOL. V.

NEW YORK, JANUARY, 1915.

No. 1.

The United States Government Collection of Postage Stamps.

BY JOSEPH B. LEAVY,
Philatelist, U. S. National Museum.

(Continued from last issue.)

- | | |
|---|---|
| 1895, wmk. \$1.00 black, gray black | — — 8c brown violet & black, deep brown violet & black |
| — — \$2.00 dark blue, bright blue, sapphire | — — 10c yellow brown & black, orange brown & black |
| — — \$5.00 dark green, dark yellow green | — — Inverted medallions, 1c green & black |
| — — Complete set handstamped "Specimen" in small type | — — 2c carmine & black |
| 1898-99, 1c deep green, yellow green | — — 4c yellow brown & black |
| — 2c orange red, rose carmine | 1902, 1c blue green, yellow green, gray green, green, dark green |
| — 4c rose brown, lilac brown, deep lilac brown, orange brown, pale orange brown | — 2c carmine, deep carmine, rose carmine |
| — 6c lake, purplish lake, claret, pale claret | — 3c bright violet, deep violet, dull violet, purple |
| — 10c orange brown, brown, yellow brown | — 4c brown, orange brown, red brown, chestnut |
| — 15c olive, yellow olive | — 5c dark blue, blue, pale blue |
| — Complete set handstamped "Specimen" in small type | — 6c claret, pale claret, brownish lake |
| 1898, Trans-Mississippi Issue, 1c dark yellow green, yellow green | — 8c violet black, gray black, gray lilac |
| — — 2c dull copper red, rosey copper red | — 10c pale red brown, red brown |
| — — 4c orange, pale orange | — 13c purple black, brown violet, deep brown violet |
| — — 5c dull blue, bright blue | — 15c olive, yellow olive |
| — — 8c violet brown, deep violet brown | — 50c orange, yellow orange |
| — — 10c gray violet, black violet | — \$1.00 black, gray black |
| — — 50c sage green | — \$2.00 dark blue |
| — — \$1.00 black | — \$5.00 dark green |
| — — \$2.00 orange brown | — Imperforate blocks of four, 1c dark green, green |
| — — Specimen, complete set handstamped in small type | — — 5c blue |
| 1901, Pan-American Issue, 1c green & black, blue green & black | 1903, 2c carmine, rose carmine, rose red, carmine lake, lake, scarlet |
| — — 2c carmine & black, scarlet & black | — Imperforate block of four, 2c rose red, carmine, lake |
| — — 4c chocolate & black, yellow brown & black | 1904, Louisiana Purchase Issue, 1c green, deep green |
| — — 5c ultramarine & black, deep ultramarine & black | — — 2c carmine, deep carmine |
| | — — 3c violet, deep violet |

- — 5c dark blue, deep blue
 — — 10c red brown, orange brown
 1907, Jamestown Exposition, 1c
 green, deep green, gray green
 — — 2c carmine, deep carmine
 — — 5c blue, deep blue
 1908-09, Wmkd. double line U S P S,
 1c green
 — — 2c carmine, lake
 — — 3c deep violet
 — — 4c orange brown, brown, pale
 brown
 — — 5c dark blue, deep blue, blue,
 pale blue
 — — 6c red orange
 — — 8c olive green
 — — 10c yellow, golden yellow
 — — 13c blue green
 — — 15c pale ultramarine
 — — 50c pale violet
 — — \$1.00 purple brown, brown
 violet
 — — Imperforate blocks of four, 1c
 yellow green, green, gray
 green
 — — — 2c carmine, lake
 — — — 3c deep bluish violet, deep
 reddish violet
 — — — 4c brown, pale brown
 — — — 5c bright blue, blue
 — Bluish rag paper, 1c green
 — — 2c carmine
 — — 3c deep violet
 — — 4c pale brown
 — — 5c blue
 — — 6c red orange
 — — 8c olive
 — — 10c yellow
 — — 13c blue green
 — — 15c pale ultramarine
 Lincoln Memorial Issue, 2c carmine
 — 2c carmine, bluish rag paper
 — 2c carmine, imperforate block of
 four
 Alaska-Yukon Issue, 2c carmine
 — 2c carmine, imperforate block of
 four
 Hudson-Fulton Issue, 2c carmine
 — 2c carmine, imperforate block of
 four
 1908-09, Government Coils, perf. 12
 vertically, 1c green
 — — — 2c carmine
 — — — 4c brown
 — — — 5c blue
 — — — 10c yellow
 — — Perf. 12 horizontally, 1c grn.
 — — — 2c carmine
 — — — 4c brown
 — — — 5c blue
 — U. S. Automatic Vending Co., 1c
 green
 — — 2c carmine
 — — 2c Hudson-Fulton
 1910, Wmkd. single line U S P S, 1c
 yellow green, green, deep grn.
 — — 2c carmine, carmine lake
 — — 3c violet, pale violet, deep
 violet
 — — 4c brown, yellow brown
 — — 5c blue, deep blue
 — — 6c red orange
 — — 8c olive
 — — 10c yellow
 — — 15c ultramarine, pale ultrama-
 rine
 — — Government Coils, perf. 12
 horizontally, 1c green
 — — — 2c carmine
 — — Perf. 12 vertically, 2c carmine
 Imperforate blocks of four, 1c
 green, deep green, yellow grn.
 — — 2c carmine, deep carmine
 — — Government Coils, perf. 8½
 vertically, 1c green
 — — — 2c carmine
 — — — 3c violet
 — — — 4c brown
 — — — 5c blue
 — — — perf. 8½ horizontally, 1c
 green
 — — — 2c carmine
 1912, 1c green, deep green
 — 2c carmine, rose carmine, lake
 — 8c olive, pale olive, pale yellow
 olive
 — 10c yellow
 — 15c gray
 — Imperforate blocks of four, 1c
 green
 — — 2c carmine
 — Government Coils, perf. 8½ hori-
 zontally, 1c green
 — — — 2c carmine
 — — — perf. 8½ vertically, 1c green
 — — — 2c carmine
 — Double impression, 2c carmine
 1912-13, Panama-Pacific, 1c green
 — — 2c carmine
 — — 5c blue
 — — 10c yellow, orange
 1914, 7c black
 — 9c salmon
 — 12c violet brown
 — 20c ultramarine
 — 30c deep orange
 — Perforated 10, 1c, 2c, 3c, 4c, 5c,
 6c, 7c, 10c, 12c
 — Government coils, perf. 10 verti-
 cally, cylindrical plates, 1c
 green
 — — — 2c carmine
 Parcel Post, 1912-13, 1c to \$1.00
 complete
 Registration stamp, 1911, 10c ultra-
 marine

POSTAGE DUE

- 1879, 1c yellow brown, brown
 — 2c yellow brown, brown
 — 3c yellow brown, brown
 — 5c yellow brown, brown
 — 10c yellow brown, brown
 — 30c yellow brown, brown
 — 50c yellow brown, brown

Specimen, overprint in small red capitals

- 1c to 50c yellow brown
 1880, Special printing, 2c deep brown
 — — 3c deep brown
 — — 5c deep brown
 — — 10c deep brown
 — — 30c deep brown
 — — 50c deep brown
 1889, 1c to 50c red brown
 1891-93, 1c claret, bright claret
 — 2c claret, bright claret
 — 3c claret, bright claret
 — 5c claret, bright claret
 — 10c claret, bright claret
 — 30c claret, bright claret
 — 50c claret, bright claret

Complete set in imperforate blocks of 4

- 1894, no wmk., 1c vermilion, deep claret
 — — 2c vermilion, deep claret
 — — 3c deep claret
 — — 5c deep claret
 — — 10c deep claret
 — — 30c deep claret, carmine
 — — 50c deep claret, carmine
 — — imperforate, 1c deep claret, pair

- 1895, Wmkd. double line U S P S, 1c to 50c
 — — Specimen handstamped in small type

- 1911-12, Wmkd. single line U S P S,
 1c deep claret
 — — 2c deep claret
 — — 3c deep claret
 — — 5c deep claret
 — — 10c deep claret

Parcel Post, 1912, 1c to 25c green

SPECIAL DELIVERY

- 1885, no wmk., 10c blue, dull blue
 — — 10c blue, Specimen overprint in small red capitals
 1888, 10c dull blue, deep blue
 1893, 10c orange, yellow orange
 1894, 10c blue, deep blue, dark blue
 1895, Wmkd. double line U S P S, 10c blue, indigo
 — — Specimen, handstamped in small type, 10c indigo

1902, 10c ultramarine, pale ultramarine

1908, 10c green

1911, Wmkd. single line U S P S, 10c pale ultramarine, deep ultramarine

1914, Perf. 10, 10c deep ultramarine

OFFICIAL STAMPS

Agriculture Department, Continental Bank Note Co., complete set 1c to 30c

— American Bank Note Co., 1c, 3c
 Executive Department, Continental Bank Note Co., 1, 2, 6, 10c
 — — carmine, 3c violet rose

Interior Department, Continental Bank Note Co., complete set, 1c to 90c

— American Bank Note Co., 1, 2, 3, 6, 10, 12, 15, 24c

Justice Department, Continental Bank Note Co., complete set, 1c to 90c purple

— — 3c, 6c bluish purple

— American Bank Note Co., 3c, 6c
 Navy Department, Continental Bank Note Co., complete set, 1c to 90c ultramarine

— — 1, 2, 3, 6, 7, 10, 24c dull blue

— — Trial colors, 2c green, 2c blk.

— American Bank Note Co., Specimen, 1c blue, overprint in red
 Post Office Department, Continental Bank Note Co., white paper, complete set, 1c to 90c
 — — Gray paper, 1, 3, 6, 10, 12, 24, 30, 90c

— American Bank Note Co., 3c
 State Department, Continental Bank Note Co., complete set, 1c to 90c dark green

— — 3c bright green, yellow green

— — 6c bright green

— — 10c bright green

— — \$2.00 green & black

— — \$5.00 green & black

— — \$10.00 green & black

— — \$20.00 green & black

Treasury Department, Continental Bank Note Co., complete set, 1c to 90c

— American Bank Note Co., 3, 6, 10, 30, 90c

War Department, Continental Bank Note Co., complete set, 1c to 90c

— American Bank Note Co., 1, 2, 3, 6, 10, 12, 30c rose red

— — 2c dull vermilion

POST OFFICE SEALS

Registered, 1872, National Bank Note Co., green on thin horizontally laid paper

| | |
|--|---|
| — 1873, Continental Bank Note Co., green on thin hard wove paper | — — — \$9.00 yellow |
| — 1879, American Bank Note Co., green on soft, porous, wove paper | — — — \$12.00 blue green |
| Officially Sealed, 1877, engraved, brown, (Post Obitum) | — — — \$24.00 dark gray violet |
| — 1879, engraved, brown | — — — \$36.00 brown rose |
| — 1888, typographed, imperforate pairs, light brown, chocolate | — — — \$48.00 red brown |
| — — — perforated 12, light brown, chocolate, bistre brown, gray brown | — — — \$60.00 violet |
| — 1892, typographed, rouletted, light brown, bistre brown | Special Printing, 2, 3, 4, 6, 8, 9, 10c black |
| — 1889-90, type-set, black, imperforate | — 12, 24, 36, 48, 60, 84, 96c pale rose |
| — — — black, rouletted, two types | 1879, American Bank Note Co., 2, 3, 4, 6, 8, 10c black |
| — 1901-03, lithographed, dark brown, red brown, gray brown, yellow brown | — 12, 24, 36, 48, 60, 72, 84, 96c red, rose red |
| — 1904, orange brown | — — — \$1.92 pale brown, brown |
| — 1907, blue | — — — \$3.00 vermilion, red vermilion |
| Postal Savings, 1911, wmkd. double line U S P S, 2c black | — — — \$6.00 blue, ultramarine |
| — — — 50c dark green | — — — \$9.00 orange, yellow orange |
| — — — \$1.00 ultramarine | — — — \$12.00 yellow green, deep yellow green, blue green |
| — — — Wmkd. single line U S P S, 1c dark violet | — — — \$24.00 dark violet, dull violet |
| — — — 2c black | — — — \$36.00 Indian red, pale Indian red |
| — — — 10c carmine | — — — \$48.00 yellow brown, pale yellow brown |
| | — — — \$60.00 purple, violet |
| | 1883, Special printing, 2c intense black |
| | 1885, 1c black |
| | — 12, 24, 36, 48, 60, 72, 84, 96c carmine |
| | 1889, Special printing, imperforate blocks of four, 1, 2, 3, 4, 6, 8, 9, 10c black |
| | — — — 12, 24, 36, 48, 60, 72, 84, 96c carmine |
| | — — — \$1.92 to \$60.00 |
| | 1894, Printed by the Bureau from American Bank Note Co. plates, 1, 2, 4, 6, 10c intense black |
| | — — — 12, 24, 36, 60, 96c pink |
| | — — — \$3.00 scarlet |
| | — — — \$6.00 pale blue |
| | 1895, no wmk. 1, 2, 5, 10c black |
| | — — — 25, 50c carmine |
| | — — — \$2.00 scarlet, \$5.00 ultramarine |
| | — — — \$10.00 green, \$20.00 slate |
| | — — — \$50.00 carmine, \$100.00 purple |
| | — Wmkd. double line U S P S, 1, 2, 5, 10c black |
| | — — — 25, 50c carmine |
| | — — — \$2.00 scarlet, \$5.00 dark blue |
| | — — — \$10.00 green, \$20.00 slate |
| | — — — \$50.00 carmine, \$100.00 purple |
| | Reprints, 1899, \$5.00, \$10.00, \$20.00, \$50.00, \$100.00 |
| | To be continued. |
| NEWSPAPER STAMPS | |
| 1865, National Bank Note Co., colored border, 5c dark blue, light blue | |
| — — — 10c green, blue green | |
| — — — 25c carmine red, orange red | |
| — — — Pelure paper, 10c green | |
| — — — — 25c orange red | |
| — — — White border, 5c dark blue, light blue | |
| — — — Pelure paper, 5c dark blue | |
| — — — Specimen overprint Gothic, 5c, white border | |
| — — — 10, 25c, colored border | |
| Reprints, 1875, Continental Bank Note Co., 5c dull blue, white border | |
| — — — 10c dark bluish green | |
| — — — 25c dark carmine red | |
| — American Bank Note Co., 1880, 5c dark blue, white border | |
| 1875, Continental Bank Note Co., 2, 3, 4, 6, 8, 9, 10c black | |
| — — — 12, 24, 36, 48, 60, 72, 84, 96c rose | |
| — — — \$1.92 brown | |
| — — — \$3.00 vermilion | |
| — — — \$6.00 ultramarine | |

THE POSTAL ISSUES OF AUSTRIA.

BY J. BRACE CHITTENDEN, Ph. D.

(Continued.)

SECOND ISSUE.



III. 65



III. 66



III. 67



III. 68



III. 69

Designed by Prof. Meissner and engraved by Messrs. Schmidt and Schrepper at the State Printing Office. Vienna.

From Nov. 1, 1858 until entirely exhausted (1861-62).

Head of Franz Joseph I. to left, embossed in white.

Illustrations 65 to 69.

TABLE 9.

1858-62.

| | | Type I. | Type II. | Transp. Paper. | Cheapest Var. T 2. | Re-marks. |
|-----|------------------|-----------|------------|----------------|--------------------|-----------|
| 6 | 2kr. yellow (3s) | 10.00 | 12.00 .75 | — | — .35 | S. |
| 6a | 2kr. orange (2s) | — | 87.50 3.00 | — | — 2.50 | S. |
| 7 | 3kr. black (2s) | 6.25 2.50 | 6.25 2.00 | — 3.00 | — 1.50 | S. |
| 8 | 3kr. green | — | 5.00 1.25 | — | — 1.25 | |
| 8a | 3kr. blue green | — | 10.00 1.75 | — 2.50 | — 1.75 | |
| 9 | 5kr. red (3s) | 20.00 .04 | 10.00 .03 | — 1.25 | — .02 | S., Senf |
| 10 | 10kr. brown (4s) | 22.50 .05 | 15.00 .04 | — 1.85 | — .05 | |
| 11 | 15kr. blue (2s) | 25.00 .05 | 17.50 .04 | — 1.85 | — .02 | S., Senf |
| 11a | 15kr. sky blue | 30.00 .06 | — | — | — .06 | K. |

Note 1. All the stamps of the first issue had been distributed to the Post Offices and were good for postage until Jan. 1st, 1859. The new issue began to be distributed Nov. 1st, 1858 and covers can be found with stamps of both issues used during one month only. The remainders in the hands of the Post Offices were returned after this date from time to time to the Central Station and the first lot received was burned June 15, 1859. In Nov. 1862 the French dealers sought to obtain remainders for collectors and were then advised by the K. K. Hof and Staatsdruckerei that they possessed no copies of the first two issues, having destroyed all that came into their possession. These facts sufficiently account for the rarity of original unused copies.

Note 2. **Paper.** A study of the paper used in this issue no longer rewards the student with the many varieties described in connection with the first issue. It is always machine made paper and no ribbed or laid varieties exist and the distinction made between thick and thin is by no means marked. Occasionally on the very thin varieties, however, through shining specimens may be discovered which are highly prized.

Note 3. A complete exhibit requires nine sets as follows:

- A. Thick paper (0.1-0.125 mm.) clear impression, Type I.
- B. Thick paper (0.1-0.125 mm.) clouded impression, Type I.
- C. Thin paper (0.075-0.09 mm.) clear impression, Type I.
- D. Thin paper (0.075-0.09 mm.) clouded impression, Type I.
- E. Thick paper (0.1-0.125 mm.) clear impression, Type II.
- F. Thick paper (0.1-0.125 mm.) clouded impression, Type II.
- G. Thin paper (0.075-0.09 mm.) clear impression, Type II.
- H. Thin paper (0.075-0.09 mm.) clear impression, Type II.
- I. Thin paper (0.075-0.09 mm.) Through shining. Both types.

F is the ordinary variety. The clear impressions are by no means common and are distinguished as follows: The embossing of the head is raised and sharp and the lines of the designs are sharp and clean cut. In the 3K. the bee hives show line shading. In the 5K. the leaves in the wreath below the head are distinct. In the 15K. the dots under the upper crown are distinct. Good clear impressions are worth full catalogue and it must be remembered that the series was in use but little over a year.

Note 4. **Varieties.** In addition to the above, a set may be obtained showing a line, part of St. Andrews Cross like an outline, either above or below the stamp. The 2k. No. 6 cut in halves and used as 1K. (2 plus 2 plus 1 equals 5) and No. 10 halved and used as 5K., esteemed by Kohl anywhere from \$30.00 to \$40.00 may exist, while pairs and strips soar skyward in the estimation of an Austrian collector. A booby head showing much larger and wider is interesting; also colored spots on the white, and white spots on the colored parts indicative of faulty impressions. A double impression is known of the 5K. (Kohl) and also of the 10K, while at least one copy of the 15K. has a double head, one reversed.

Note 5. **Perforations.** This issue is historically interesting, as marking the introduction of the line perforating machine designed first by Grunberger and perfected by Andreas Gotthardt, to perforate an entire sheet of stamps in one direction only. At first they corresponded to sheets of 64 stamps and later to those of a hundred and were used exclusively until 1898 when machines were introduced to perforate the sheets horizontally as well as vertically at the same time and were thereafter used in conjunction with the former. The difference in the paper alone, would have rendered it necessary to employ the line perforating machine exclusively during this issue and three machines were in use until 1898. The stamps were therefore perforated with considerable regularity but not as a rule well centered; indeed, often showing part of the next stamp or the Cross.



Ill. 70



Ill. 71

Note 6. **Types.** Except in case of the 2K. the two types are easily distinguished as follows:

Type I. (Ill. 70). The loops of the bow at the back of the head are broken, forming a resemblance to the figure 3, the profile of the wreath at the top of the head is blunted and the ends of the bow are short and blurred.

Type II. (Ill. 71). The loops of the bow at the back of the head are complete, forming a resemblance to the figure 8, the ends are longer and more distinct and the profile of the wreath at the top of the head shows sharp points. The two types of the 2k. are much harder to distinguish, the foregoing distinctions being as a rule conspicuous by their absence. The lines in the throat are sharp and clearly defined in Type I. Dr. Levith (ILL. B. J. p. 255, 1908) says Type I may show color in the eye and ear points or on the neck whereas the bust in Type 2 is perfectly white. It is a much prized variety if you are certain of it, and a rarity when unused.

Aside from the above the 15K. Type I has a large period after the R which is absent in Type 2. The 2K. orange and 3K. green exist only in Type 2. The 3K. value was changed from black to green to conform to the rule adopted by the Postal Union, Mar. 16th, 1859 which should account for the failure to find their colors in Type I.

Note 7. **Errors in Printing** may be detected, such as points or spots of color on the face and neck, and in particular, a great difference exists with respect to the clearness of the impression in shade and quantity of color retained on the stamp to be traced to the use of clean or soiled machinery. One variety in particular, shows a much larger bust, resembling the "Booby-head" on the U. S. envelopes.

Note 8. **St. Andrews Crosses** continued to be used in this issue and they form when all have been obtained, a handsome exhibit, furnishing a more interesting study because of their variations than do those of the issue of 1850. American collectors would be amazed to know how scarce they are and how highly they are prized in Europe. They may be described as two white lines forming a cross of varying thickness, on a background of the same coloring as the stamp to which it belongs, with or without a white border, and with or without from one to four white dots on the left border. They are perforated 15. The crosses fall into two Types, corresponding to those of the stamps.

Type I. The colored background measures 20 by 24 mm. and is without a white border.

Type II. The colored background measures 17 by 20½ mm. and is framed with a white border. All the values occur in Type I. but the 3K. black or green have yet to be discovered in Type 2. In Type I and also Type 2, one finds (a) no white dots; (b) one dot; (c) two dots in the left side. Type 2 in addition shows (d) three dots and (e) four dots. These dots are comparatively large and must not be confused with irregular white spots that occur in Type I, due to failures in printing. Kohl quotes the following prices making no distinction as to Type.

TABLE 10.

| St. Andrews Cross. (1858-62). | | | |
|-------------------------------|-------------|--------------------------|-------------|
| Cross without stamp. | | Cross attached to stamp. | |
| 2K. Yellow |\$.50 | 2K. Yellow | ——— |
| 2K. Orange | 5.00 | 2K. Orange | ——— |
| 3K. Black | 2.50 | 3K. Black | ——— |
| 3K. Green | 1.90 | 3K. Green | ——— |
| 5K. Red |25 | 5K. Red | 25.00 |
| 10K. Brown |25 | 10K. Brown | 37.50 |
| 15K. Blue |25 | 15K. Blue | 62.50 |

Stamps with traces of the Cross, appearing like an outer line are prized and bring increased values; and specimens with one or more entire crosses adhering, are rarities. On covers they are of course the rarest of all and very highly prized, especially when cancelled. The Crosses themselves will not be obtained easily. Apparently to remedy this defect they have been liberally counterfeited, including the white dots and those I have seen are in different shades from the originals and on modern machine made paper.

Note 9. **Statistics.** Records show the following deliveries at the Post Office.

| | | | |
|------------|-------------------|------------|--------------------|
| 2K. yellow |22,080,000. | 5K. red | 108,000,000. |
| 3K. black | 14,400,000. | 10K. brown | 98,400,000. |
| 3K. green | 40,800,000. | 15K. blue | 96,400,000. |

All of them were distributed but notice was given of their approaching demonetization and the postmasters and the public were permitted to exchange them for new issues for a short period. All that were thus returned were destroyed by burning, one record alone mentioning 65000 of the several varieties including doubtless many of the first issue. As early as 1862 efforts were made by a dealer in France, to secure remainders of the first two issues, but was advised that all that had ever been returned to the bureau had been

burned. True uncanceled specimens are therefore those, comparatively few in number, that remained in the hands of the public unredeemed. This method was, I understand, continued for a long time and differs from that of other countries. Austria has manufactured and sold reprints without limit but has destroyed the originals, and demonetized them to insure a maximum profit. Since the reprints of Austria are unmistakable in most cases, this practice has much to commend it especially from the standpoint of the collector. The United States demonetized issues made prior to the Civil War only and caused all reprints of stamps of later date to be good for postage, creating practically new issues. The worst practice followed by many countries, for example Spain and Portugal, is to sell the remainders at a reduced price.

TABLE 11.

Reprints of the Issue of 1858-9.**Reissue of 1866—480 sets.**Smooth white p. T II white gum. P. 12 (11 $\frac{3}{4}$ -12 $\frac{1}{4}$)

| | | |
|----|------------------|------|
| 6 | 2K. dark yellow | 4.00 |
| 7 | 3K. black | 4.00 |
| 8 | 3K. green | 4.00 |
| 9 | 5K. red | 4.00 |
| 10 | 10K. gray brown | 4.00 |
| 11 | 15K. bright blue | 4.00 |

Reissue of 1870—5000 sets.Thick hard white p., T. II, yellow gum, p. 10 $\frac{1}{2}$ (10 $\frac{1}{4}$ -11)

| | | |
|----|--------------------|-----|
| 6 | 2K. light yellow | .40 |
| 7 | 3K. black | .60 |
| 8 | 3K. light green | .60 |
| 9 | 5K. red | .08 |
| 10 | 10K. reddish brown | .12 |
| 11 | 15K. bright blue | .18 |

Reissue of 1884—2500 sets.

Thin white paper, T. II, white gum, p. 13 and imperf.

| | | |
|----|-----------------------|------|
| 6 | 2K. bright yellow | .60 |
| 7 | 3K. black | 1.25 |
| 8 | 3K. light olive green | 1.25 |
| 9 | 5K. red | .38 |
| 10 | 10K. reddish brown | .45 |
| 11 | 15K. bright blue | .50 |

Reissue of 1887-89—10,000 sets.

| | | |
|---|------------------------------------|-----|
| Thin white p., white gum, T. II, P. 12 (11 $\frac{3}{4}$ -12 $\frac{1}{4}$ -12 $\frac{1}{2}$.) 2K. and 3K. only. | | |
| | 2K. yellow | .10 |
| | 2K. yellow imperf. | — |
| | 2K. orange | .10 |
| | 2K. orange imperf. | — |
| | 3K. black (12 $\frac{1}{2}$) | .12 |
| | 3K. black imperf. | — |
| | 3K. light green | .12 |
| | 3K. light green imperf. | — |
| | 2K. orange (12 $\frac{1}{2}$) '89 | .10 |

Note 10. None of the reprints are perforated 15 like the originals and are therefore easily detected. The 2K. and the 3K. will be found in most of the old collections and in but few of the late ones; a silent reminder of the new code of honesty now prevailing. The issue of 1888 is the most dangerous because of the perforations. Other than these Government examples of the difficulties not successfully overcome even when you possess original plates and attempt to reproduce a stamp, counterfeits of this issue are rare enough to be prized. I possess two of the green and one of the black that are good enough to be remarkable if it were not for the perforations and the outrageous fake cancellations; they are both of the Lombardy Venice Type.

THIRD ISSUE.



III. 72

Engraved by J. Radnitzki, Vienna.

From Jan. 15, 1861 until May 31st, 1864.

Bust of the Emperor to right, embossed in white on smooth paper and framed with a double ellipse filled with elliptical interlacing lines. Above Kreuzer, below, the cliche of value: per. 14. (14¼) No Wmk.

Illustration 72.

TABLE 12. (1861-64).

| | | A.B.C.D. | E. | Cheapest quotation | Remarks |
|----|-----------------|----------|--------|--------------------|---------|
| 12 | 2K. Yellow (3s) | 1.50 .38 | — | — | .35 S. |
| 13 | 3K. green (3s) | 1.50 .38 | — 1.85 | — | .15 S. |
| 14 | 5K. red (3s) | 1.25 .01 | — 1.25 | — | .01 K. |
| 15 | 10K. brown (4s) | 3.00 .04 | — 1.25 | — | .03 S. |
| 16 | 15K. blue | 3.00 .02 | — 1.25 | — | .02 K. |

Note 1. Five sets may be exhibited in this issue.

- A. Clear impression, raised embossing, paper thickness less than 1 mm.
- B. Clouded impression, flat embossing, paper thickness less than 1 mm.
- C. Clear impression, raised embossing, paper thickness greater than 1 mm.
- D. Clouded impression, flat embossing, paper thickness greater than 1 mm.
- E. Through shining impression.

Varieties C and D on thick paper are scarcer than A and B. The 3K. No. 13 is known with a double impression, once on the back. The 5K. No. 14 with the head struck twice, once reversed, and also the 15K. No. 16 (ILL. B. J. '08 p 290). The 10K. No. 15 is also known halved and used as 5K.

At first the embossing was very high and sharp but in the later impressions flat and clouded. Failures of printing are known such as colored points on the white and white points on the colored portions. The blue, ultramarine and the yellow brown shades are much scarcer than the others.

Note 2. **Outer lines** in the color of the stamps exist on the sheets of all the values but are very scarce as only the very poor centering on the border stamps will show them, the perforating as a rule serving to remove them. They are as follows:

- 2K. yellow with 3 parallel lines.
- 3K. green with 1 thick line.
- 5K. red with 3 parallel lines.
- 10K. brown with 3 parallel lines.
- 15K. blue with 3 parallel lines.

Note 3. Envelope stamps cut and used as postage stamps were by a decree of the Post Office Dept. prohibited (April 10, 1866) but prior to this date and occasionally thereafter they were so used and passed through the post. Prior thereto in 1862 the envelopes might be so used with permission of the government provided they were not cut out but left with the flap attached. They were supposed to be stamped thereon, with a special mark of the postmaster, and were nearly all used exclusively in Hungary.

Envelope Stamps Cut and Used as Postage Stamps in 1861.

| | | | |
|-------|-------------------|--------|-------|
| I. | 3K. green | 11.00 | 5.00 |
| II. | 5K. red | 2.50 | 1.25 |
| III. | 10K. brown | 3.75 | 2.50 |
| IV. | 15K. blue | 3.75 | 2.50 |
| V. | 20K. orange | 62.50 | |
| VI. | 26K. dark brown | 50.00 | 18.75 |
| VII. | 30K. violet | — | 33.75 |
| VIII. | 35K. ginger brown | 110.00 | — |

TABLE 13.

Reprints of the Issue of 1861.

Reissue of 1866—500 sets.

Smooth white paper, white gum, p. 12.

| | | |
|----|------------------|------|
| 12 | 2K. light yellow | 4.00 |
| 13 | 3K. yellow green | 4.00 |
| 14 | 5K. red | 4.00 |
| 15 | 10K. red brown | 4.00 |
| 16 | 15K. dark blue | 4.00 |

Reissue of 1870—5000 sets.

Thick, white paper, yellowish gum, p. 10½ (9-10¾).

| | | |
|----|-------------------|-----|
| 12 | 2K. orange yellow | .25 |
| 13 | 3K. yellow green | .50 |
| 14 | 5K. red | .08 |
| 15 | 10K. red brown | .12 |
| 16 | 15K. dark blue | .18 |

Reissue of 1884—2500 sets.

Thin smooth white paper, white gum, p. 13 or imperf.

| | | |
|----|-----------------------|-----|
| 12 | 2K. citron yellow | .25 |
| 13 | 3K. light olive green | .25 |
| 14 | 5K. light orange | .12 |
| 15 | 10K. light red brown | .18 |
| 16 | 15K. bright blue | .25 |

Reissue of 1887—10000 sets.

Thin smooth white paper, white gum, P. 12-12½ or imperf.

| | | |
|----|----------------------|-----|
| 12 | 2K. yellow or orange | .06 |
| 13 | 3K. green | .06 |

(To be continued.)

NEW PLATE NUMBERS.

Through the courtesy of Mr. J. E. Ralph, Director of the Bureau of Engraving and Printing, we are enabled to furnish our readers with the full list of plate numbers to January 1, 1915:

| No. | Den. | Class. | No. | Den. | Class. |
|------|------|----------|------|------|----------|
| 7182 | 1c | Ordinary | 7231 | 2c | " |
| 7183 | 1c | " | 7232 | 2c | " |
| 7184 | 2c | " | 7233 | 2c | " |
| 7185 | 2c | " | 7234 | 2c | " |
| 7186 | 2c | " | 7235 | 5c | " |
| 7187 | 2c | " | 7236 | 5c | " |
| 7188 | 2c | " | 7237 | 5c | " |
| 7189 | 2c | " | 7238 | 5c | " |
| 7190 | 2c | " | 7239 | 5c | " |
| 7191 | 2c | " | 7240 | 5c | " |
| 7192 | 2c | " | 7241 | 5c | " |
| 7193 | 2c | " | 7242 | 5c | " |
| 7194 | 2c | " | 7243 | 2c | Book |
| 7195 | 2c | " | 7244 | 2c | Ordinary |
| 7196 | 2c | " | 7245 | 2c | " |
| 7197 | 2c | " | 7246 | 2c | " |
| 7198 | 2c | " | 7247 | 2c | Book |
| 7199 | 2c | " | 7248 | 2c | Ordinary |
| 7200 | 2c | " | 7249 | 2c | Book |
| 7201 | 2c | " | 7250 | 2c | " |
| 7202 | 2c | " | 7251 | 2c | Ordinary |
| 7203 | 2c | " | 7252 | 2c | " |
| 7204 | 10c | " | 7253 | 3c | " |
| 7205 | 10c | " | 7254 | 3c | " |
| 7206 | 2c | " | 7255 | 2c | " |
| 7207 | 2c | " | 7256 | 2c | Book |
| 7208 | 2c | " | 7257 | 2c | Ordinary |
| 7209 | 2c | " | 7258 | 3c | " |
| 7210 | 2c | " | 7259 | 2c | " |
| 7211 | 2c | " | 7260 | 2c | Book |
| 7212 | 2c | " | 7261 | 2c | Ordinary |
| 7213 | 10c | " | 7262 | 3c | " |
| 7214 | 2c | " | 7263 | 4c | " |
| 7215 | 10c | " | 7264 | 2c | " |
| 7216 | 2c | " | 7265 | 2c | " |
| 7217 | 2c | " | 7266 | 3c | " |
| 7218 | 2c | " | 7267 | 3c | " |
| 7219 | 2c | " | 7268 | 1c | Book |
| 7220 | 2c | " | 7269 | 4c | Ordinary |
| 7221 | 2c | " | 7270 | 2c | " |
| 7222 | 2c | " | 7271 | 2c | " |
| 7223 | 2c | " | 7272 | 3c | " |
| 7224 | 2c | " | 7273 | 4c | " |
| 7225 | 2c | " | 7274 | 3c | " |
| 7226 | 2c | " | 7275 | 1c | Book |
| 7227 | 2c | " | 7276 | 4c | Ordinary |
| 7228 | 2c | " | 7277 | 1c | Book |
| 7229 | 2c | " | 7278 | 1c | " |
| 7230 | 2c | " | | | |



Fig 1



Fig 2



Fig 3



Fig.4



Fig.5



Fig.6



Fig.7



Fig.8



Fig 9



Fig 10



Fig.11.



Fig 12



Fig.13



Fig.14



Fig.15

A Detailed History of the General Issues of United States Postage Stamps from 1847 to 1890.

BY

CARROLL CHASE, ARTHUR E. OWEN AND WILLIAM B. SPRAGUE.

Picture Cancellations.

The accompanying cut shows a number of cancellations which have been found on United States postage stamps between the years 1860 and 1885. The variety of cancellations of this character during this period was so great that we believe it impracticable to illustrate or even to describe all that have come to our notice, and we attempt here merely to list those which are peculiarly striking and which have become somewhat famous among collectors.

- Fig. 1. Soldiers head, in black, seen on 30c 1861.
- Fig. 2. Flying chicken, in black, seen on 1c, 1869, used in Waterbury, Conn.
- Fig. 3. Anchor, in black, seen on 3c 1861, (one other type of anchor seen on this stamp).
- Fig. 4. Flying bird, in blue, seen on 3c 1861, (one other type of flying bird, also in blue, seen on this stamp).
- Fig. 5. National shield, in black, seen on 3c 1861, used in Boston, Mass. (fifteen other types of national shield seen on this stamp, also a different type on 3c 1873).
- Fig. 6. Rooster, in black, seen on 3c, 1861.
- Fig. 7. Flag, in black, seen on 3c 1861 (one other type of flag (in circle) seen on this stamp).
- Fig. 8. Shield with "bar sinister" in blue, seen on 2c 1882 also on Department stamps, used in Woodsburgh, N. Y.
- Fig. 9. Caricature, in black, known as the "Jeff. Davis cancellation" seen on 3c 1861, (two other types of caricature seen on this stamp, and three different ones on 1873 issue).
- Fig. 10. Honey bee, in black, seen on 3c, 1861.
- Fig. 11. Devil with pitchfork, in black, seen on 3c 1861, used in Meriden, Conn.
- Fig. 12. Eagle and shield, in black, seen on 3c 1861 (one other type of eagle and shield, with U. S., seen on this stamp).
- Fig. 13. Skull and crossbones, in black, seen on 3c 1873, (3 other types of skull and crossbones seen on this stamp, and one of skull only, on 3c 1861).
- Fig. 14. Padlock, in black, seen on 3c 1861.
- Fig. 15. Kicking mule, in black, seen on 3c 1879, 1c 1882 and on Department stamps, used in Port Townsend, Washington.

The writers would be grateful for any additional information in regard to the above, and all such communications should be addressed to Wm. B. Sprague, 54 William St., New York. We wish to make grateful acknowledgement to Senator E. R. Ackerman for his loan to us of the originals of Figs. 2 and 15.

(To be continued).

 The logo for 'THE PHILATELIC GAZETTE' is enclosed in a rectangular border. The word 'THE' is in a smaller font above 'PHILATELIC', and 'GAZETTE' is to the right of 'PHILATELIC'.

Published the 15th day of each month

J. KLEMANN, Jr., Editor.

CLIFTON A. HOWES, Special Contributing Editor.

JOHN A. KLEMANN, Managing Editor.

Staff Writers.

CHARLES LATHROP PACK

VICTOR M. BERTHOLD

J. MURRAY BARTELS

DR. CARROLL CHASE

A. E. OWEN

W. B. SPRAGUE

B. W. H. POOLE

SUBSCRIPTION \$1.00 A YEAR, SINGLE NUMBERS 10c.

Advertising Rates: 20c a line; one inch, \$1.80; ¼ page \$6.00; ½ page \$10.; page \$18.

NASSAU STAMP CO., Publishers, 118 NASSAU ST., NEW YORK.

VOL. V.

NEW YORK, JANUARY, 1915.

No. 1.

EDITORIAL.

With the advent of the new year and the beginning of a new volume, resolutions and purposes seem to be in order, but these we will dismiss with practically a word—progress and growth.

The past year has been one of experiment with us and it has proved to us conclusively that there is a strong demand for a publication like the GAZETTE.

But in order to secure this growth and progress it is necessary that we have the help and co-operation of our readers, on whom we have to depend largely for news and items of interest, keeping in mind always, that the policy of the GAZETTE from the beginning has been to publish original articles. We look to the dealers for their support in our advertising department and we believe that our policy in this regard during the year has been such as to establish confidence even in the minds of the most skeptical.

Announcement.

Through the courtesy of the J. M. Bartels Co., the Editor of the PHILATELIC GAZETTE offers a mint copy of an entire envelope, priced at \$50.00 by Bartels Catalogue, for the best communication by a reader of the GAZETTE on the desirability and need of supplying collectors of cut square envelopes with a special cut square envelope album. All communications must be addressed to the Editor of the PHILATELIC GAZETTE and reach this office not later than February 1.

SHORT NOTES AND NEWS.

From the Annual Report of Mr. J. E. Ralph, Director of the Bureau of Engraving and Printing, for the fiscal year ended June 30, 1914, we print the following items which we believe will be of interest to our readers.

Postage Stamps.

In the first month of the fiscal year the balances of postage stamps on hand in the vault of this bureau were counted by inspectors of the Post Office Department, who found a balance of 1,322,375,053 stamps, which tallied exactly with the record of balances of stamps then on hand. Due to the large orders for these stamps in the latter part of the year, the vault stock at the close of the year had fallen to 1,180,026,680 stamps. The depleted stock, however, has since been brought up to normal.

Rotary Plate Printing Press.

A rotary web plate printing press was constructed from plans designed by the mechanical expert of this bureau, and after several years experimenting it is now working satisfactorily. Postage stamps printed in rolls on this press have been made into coils which have for several months been issued to postmasters for sale for use in stamp-vending and stamp-affixing machines. A device for gumming postage stamps has been attached to the press. Four more of the presses have been ordered to be used in printing postage and revenue stamps. It is expected that an annual economy of several hundred thousand dollars will be effected when the printing of postage stamps and of certain revenue stamps has been transferred to these machines.

Statement showing the United States postage stamps delivered to postmasters, during the fiscal year 1914.

| | | | |
|------------------|----------------|--|-------------|
| Ordinary: | | Series of 1914— | |
| Series of 1902— | | 7-cent | 9,524,400 |
| 2-dollar | 506 | 9-cent | 8,554,500 |
| 5-dollar | 1,100 | 12-cent | 7,858,500 |
| | | 20-cent | 4,158,800 |
| Total | 1,616 | 30-cent | 2,852,300 |
| Series of 1908— | | Total | 32,948,500 |
| 3-cent | 80,212,797 | 10-cent special delivery, series of 1902 | 19,493,500 |
| 3-cent (Coils) | 1,997,500 | 10-cent registry, series of 1911 | 3,223,620 |
| 4-cent | 128,767,997 | Postage due, series of 1894: | |
| 4-cent (Coils) | 2,617,500 | 1-cent | 6,198,197 |
| 5-cent | 157,539,097 | 2-cent | 25,603,397 |
| 5-cent (Coils) | 1,216,000 | 3-cent | 545,397 |
| 6-cent | 57,861,097 | 5-cent | 1,041,297 |
| Total | 430,211,988 | 10-cent | 6,175,747 |
| Series of 1911— | | 30-cent | 207 |
| 1-cent | 3,553,563,200 | 50-cent | 217 |
| 1-cent (Books) | 244,040,400 | Total | 39,564,459 |
| 1-cent (Coils) | 194,496,000 | Panama-Pacific commemorative stamps, series of 1912: | |
| 1-cent } (Books) | 27,185,760 | 1-cent | 84,818,370 |
| 2-cent } | 27,185,760 | 2-cent | 138,369,700 |
| 2-cent | 5,271,846,100 | 5-cent | 3,965,150 |
| 2-cent (Books) | 308,876,760 | 10-cent | 3,047,729 |
| 2-cent (Coils) | 496,189,000 | Total | 230,200,949 |
| 8-cent | 40,616,300 | | |
| 10-cent | 103,420,197 | | |
| 15-cent | 23,038,120 | | |
| 50-cent | 1,148,997 | | |
| 1-dollar | 67,331 | | |
| Total | 10,291,673,925 | | |

| Parcel post, series of 1912: | | Parcel post dues, series of 1912: | |
|------------------------------|--------------------|--|------------------|
| 1-cent | 28,388,705 | 1-cent | 648,045 |
| 2-cent | 45,039,199 | 2-cent | 721,534 |
| 3-cent | 9,468,634 | 5-cent | 140,805 |
| 4-cent | 10,849,594 | 10-cent | 878,584 |
| 5-cent | 13,853,974 | 25-cent | 100 |
| 10-cent | 5,612,224 | Total | 2,389,068 |
| 15-cent | 4,041,589 | Postal-savings stamps for official mail: | |
| 20-cent | 2,881,129 | 1-cent | 267,499 |
| 25-cent | 3,071,565 | 2-cent | 365,699 |
| 50-cent | 758,615 | 10-cent | 287,749 |
| 75-cent | 3,380 | 50-cent | 7,524 |
| 1-dollar | 24,975 | 1-dollar | 6,249 |
| Total | 123,993,583 | Total | 934,720 |

**Statement showing the postage stamps delivered to Canal Zone government
during the fiscal year 1914.**

| Postage due, series of 1894, surcharged Canal Zone: | |
|--|----------------|
| 1-cent | 100,000 |
| 2-cent | 100,000 |
| 10-cent | 100,000 |
| Total | 300,000 |

**Statement showing the Philippine postage stamps delivered to the government
of the Philippine Islands during the fiscal year 1914.**

| | | | |
|----------------------|------------|------------------------------|-------------------|
| Philippine ordinary: | | 16-centavo | 500,019 |
| 2-centavo | 12,000,019 | 20-centavo | 1,000,019 |
| 2-centavo (Books) | 1,680,480 | 30-centavo | 100,019 |
| 4-centavo | 3,000,019 | 1-peso | 200,019 |
| 4-centavo (Books) | 336,240 | 10-peso | 10,019 |
| 6-centavo | 1,000,019 | Total | 22,326,929 |
| 8-centavo | 500,019 | Philippine special delivery, | |
| 10-centavo | 1,500,019 | 20-centavo | 100,019 |
| 12-centavo | 500,019 | | |

**Statement showing the annual deliveries in sheets of stamps by the Bureau of
Engraving and Printing from 1895 to date.**

| Fiscal year— | Postage stamps | Parcel-post stamps | Fiscal year— | Postage stamps | Parcel-post stamps |
|--------------|----------------|--------------------|--------------|----------------|--------------------|
| 1895 | 21,873,682 | | 1905 | 58,382,629 | |
| 1896 | 30,647,771 | | 1906 | 62,572,568 | |
| 1897 | 31,029,882 | | 1907 | 69,884,713 | |
| 1898 | 35,110,730 | | 1908 | 75,714,023 | |
| 1899 | 39,522,973 | | 1909 | 86,896,236 | |
| 1900 | 40,274,977 | | 1910 | 89,714,620 | |
| 1901 | 42,350,880 | | 1911 | 97,734,242 | |
| 1902 | 46,058,595 | | 1912 | 96,653,398 | |
| 1903 | 52,738,681 | | 1913 | 100,708,964 | 14,223,835 |
| 1904 | 55,244,616 | | 1914 | 107,488,047 | 2,808,654 |

NEW ISSUES.

Mr. Laurence B. Mason informs us that the postal authorities at Lisbon have decided to put in circulation all the old issues still to be found at the mint, and in order to use up these remainders purpose issuing 108 stamps surcharged with a new rate, apportioned among the following 12 colonies, with a total face value of \$9.72. The number of each issued is not given but the assurance is given that this is the end of these provisional surcharges.

List of postage stamps of the Portuguese Colonies printed with the various surcharges created by the decrees of April 24, 1903 and March 20, 1905.

Surcharged on Don Luis Issue.

Angola, 115 on 10r, 115 on 200r, 130 on 100r.
 Cape Verde, 115 on 10r, 115 on 20r, 130 on 50r, 130 on 100r.
 Guinea, 115 on 40r, 115 on 50r, 130 on 80r, 130 on 100r.
 India, 5T on 8T.
 Macao, 6 on 10r.
 St. Thomas, 115 on 10r, 115 on 300r, 130 on 5r, 130 on 200r.

Surcharged on Don Carlos Issue.

Angola, 115 on 80r, 115 on 100r, 115 on 150r, 130 on 15r, 130 on 75r, 130 on 300r.
 Cape Verde, 115 on 5r, 115 on 25r, 115 on 150r, 130 on 75r, 130 on 80r, 130 on 200r.
 Congo, 115 on 2½r, 115 on 10r, 115 on 50r, 130 on 5r, 130 on 75r, 130 on 100r. 50 and 15 Provisorio, 50 on 65r.
 Guinea, 115 on 2½r, 115 on 5r, 115 on 25r, 130 on 150r, 130 on 200r, 130 on 300r, 15 and 50 Provisorio, 50 on 65r.
 India, 2T Provisorio, 2T on 2½r.
 Inhambane, 50 on 65r.
 Lourenço Marques, 115 on 10r, 115 on 200r, 115 on 300r, 130 on 150r.
 Macao, 6 on 5r, 6 on 10r, 6 on 15r, 6 on 25r, 6 on 80r, 6 on 100r, 6 on 200r, 18 on 2½r, 18 on 20r, 18 on 50r, 18 on 75r, 18 on 150r, 18 on 300r, 8 and 10 Provisorio, 10 on 12r. 130 on 200r, 50 Provisorio, 50 on 65r.
 Mozambique, 115 on 2½r, 115 on 5r, 115 on 25r, 130 on 75r, 130 on 150r, 130 on 300r, 50 Provisorio, 50 on 65r.
 St. Thomas, 115 on 25r, 115 on 150r, 115 on 200r, 130 on 75r, 130 on 100r, 130 on 300r, 50 Provisorio, 50 on 65r.
 Timor, 5 on 5r, 5 on 25r, 5 on 50r, 6 on 2½r, 6 on 20r, 9 on 15r, 9 on 75r, 15 on 10r, 15 on 100r, 15 on 300r, 22 on 80r, 22 on 200r, 3 avos Provisorio, 10 on 12r.
 Zambesia, 115 on 5r, 115 on 25r, 115 on 80r, 130 on 2½r, 130 on 75r, 130 on 150r, 50 Provisorio, 50 on 65r.

Bound Volumes of The Philatelic Gazette.

Subscribers desiring bound volumes of the GAZETTE may forward their loose copies to us and we will have them bound in blue cloth, uniform with the previous volumes. Missing numbers will be furnished at 15 cents each. Applications for binding must reach us by February 15 to insure the minimum charge.

NOTE:—Through an error, the pages of the July and August issues were numbered alike, and in order to distinguish between them we have added the letter A after those pages referring to the August issue.

NASSAU BLANK ALBUMS.

The Nassau Album.

A blank, loose leaf album gotten up regardless of expense, in the best possible manner and at the lowest price consistent with the production of a superior article.

This album can be had with either method of fastening, peg type or spring back, bound in maroon or green morocco leather, with protecting sheets of Japan or "glass" paper, the latter especially adapted for the chalky British Colonials. Size of pages, 10 3/8 x 8 3/8 inches.

Price in any quantity \$7.00 net. Additional pages, 8c each.

The Popular Blank Album.

The cheapest blank album on the market, contains 80 pages, 11 1/8 x 8 1/2 inches, linen hinged, quadrille ruled, handsomely bound in green cloth with spring back and the latest patented devices for preventing the leaves from slipping to the bottom when the album is kept in an upright position.

Price\$3.75 net.

The Larger Popular Blank Album.

Similar in every respect to our Popular Blank Album above described but containing 50 leaves, 14x10 1/2 inches of heavier quality. This album is especially desirable for complete and reconstructed sheets of stamps.

Price\$3.75 net.

Additional pages can be supplied at 5c each.

PHILATELIC ACCESSORIES.

A full line of these necessary articles always on hand.

Watermark detector, 20c

Compass & divider, \$1.50

TWEEZERS.

Seven different kinds to select from to suit every touch.

- No. 1, the cheapest 15c
- No. 2, narrow rounded points ... 30c
- No. 3, broad square points 35c
- No. 4, narrow rounded points ... 50c
- No. 5, narrow rounded points ... 50c
- No. 6, broad rounded points ... 50c
- No. 7, broad rounded points 50c

These are all highly finished, nickel plated with rough finger grip and smooth points. Leather sheath for any of the above supplied at 5c.

Hinges.

The Nassau hinge, a perfect peelable hinge on thin white transparent paper, pure and tasteless gum. In envelopes of 1,000 10c. In tin boxes with utility watermark detector on the bottom 15c

Add 5c postage for accessories ordered by mail.

NASSAU STAMP CO.

118 Nassau St.

New York, N. Y.

Our next sale will take place
MONDAY, JANUARY 25, 1915
in Philadelphia
19th and 20th Century

Empire Stamp Co. of Pennsylvania
Empire Bldg.,
13th and Walnut Sts., Philadelphia, Pa.

WHEN REMOUNTING

Your Collection, especially when working on your *favorite countries*, be sure to send for our *specialized selections* of same. Some 300 books holding 175 to 300 stamps each are now ready to be submitted. These contain our very *choicest stock* with special attention to items likely to interest the specialist. They generally include *blocks, shades* and *minor varieties*, strongest in early issues.

Our Pink List gives full information regarding these books. Moderate prices.

J. M. BARTELS CO.
99 Nassau Street, New York.

WAR-STAMPS 1914

Offer of war Stamps used or unused, one price.

| | | |
|--|--------|---------|
| France: 10 cts. Red Cross 2 diff. incl. one Provisional. | \$.13 | per set |
| Monaco: 10 cts. Red Cross 1 value Provisional. | .10 | piece |
| Belgium-German complete 3, 5, 10, 25 cts. surcharged, unused only | .12 | set |
| Austria: Charity-stamps 5 & 10 H. for war | .06 | set |
| Hungary: Charity-stamps 1, 2, 3, 5, 6, 10 Filler, previous issue for war | .14 | set |
| Hungary: complete, 1, 2, 3, 5, 6, 10, 12, 16, 20, 25, 30, 35, 50, 60 Filler, 1, 2, 5 Krone, previous issue for war | 2.80 | set |
| Bosnia: Charity-Stamps 5 & 10 H, provisional issue for war | .06 | set |

Payments can be made in Cheques or Bank-notes
Small amounts can be paid in unused stamps

Collectors may demand a specimen of my newspaper which counts 56 pages, gratis and post-paid.

To dealers I send on request my new wholesale Price-list gratis and post-paid.

Bela Szekula,

Lucerne, Switzerland

I hold one of the

Finest Stocks

of rare and medium stamps in Europe.
My Specialties are

High Class Selections

of stamps of all countries and filling of want lists a/c to any catalogue. Owing to my systematic and continual fresh purchases, serious collectors have a good opportunity of acquiring "hard to get" stamps at moderate prices.

FOR SPECIALISTS,

interesting items in great variety.

W. HOUTZAMER,

368, Strand,

London, England.

(Formerly of The Hague, Holland)

(Member of the Chicago Phil. Society, and of the American Phil. Society.)

In order to show my low prices, I offer the following all in fine condition.

BRITISH GUIANA.

| | |
|---------------------------------|---------|
| *1875, 4c ultram. perf. 12½ | \$37.50 |
| 4c ultram. perf. 12½ | 11.00 |
| 1ct slate 14x12½ | 12.00 |
| *1878, 2c on 8c official (84) | 15.00 |
| * 2c on 8c official (90) | 7.50 |
| *1881, 1ct on 48c official (95) | 2.00 |

Officials.

| | |
|----------------------|-------|
| *1875, 2cts orange | 5.00 |
| 8cts rose | 4.50 |
| * 12cts lilac | 37.50 |
| 12cts lilac | 24.00 |
| * 24cts green | 30.00 |
| 24cts green | 15.00 |
| 1877, 6cts chocolate | 20.00 |

UNITED STATES.

| | |
|----------------------------|-------|
| 1857-60, 24cts grey lilac | 2.50 |
| 30cts orange | 3.00 |
| * 90cts blue | 12.00 |
| 1861, 10cts dark green | 5.00 |
| 5cts buff | 3.75 |
| 24cts red lilac | .50 |
| 30cts orange | .50 |
| *1862-6, 3cts scarlet (74) | 45.00 |
| 5cts red brown | 1.75 |
| 15cts black | .50 |
| 1867, 3cts rose (79) | 6.00 |
| 24cts grey lilac (99) | 3.00 |
| 30cts orange (100) | 2.00 |
| 90cts blue (101) | 5.00 |
| 1869, 24cts green & violet | 2.50 |
| 90cts black & carmine | 9.00 |

THE PHILATELIC GAZETTE

PUBLISHED MONTHLY FOR STAMP COLLECTORS

VOL. V.

NEW YORK, FEBRUARY, 1915.

No. 2.

The United States Government Collection of Postage Stamps.

BY JOSEPH B. LEAVY,
Philatelist, U. S. National Museum.

STAMPED ENVELOPES

- 1853-55, 3c red, type I
Heads 1, 2, 4, 7, 8, 9 and 10 on buff, used
Heads 3, 5 and 6 on white, used
— 3c red, type II
Heads 1 and 11 on buff
Head 12 on white
— 3c red, type III
Heads 13 and 14 on buff
— 3c red, type IV
Head 1 on white
— 3c red, type V, head 15
Varieties 1, 5, 8, 10, 12, 13, 15, 16, 17, 18, 19, 20, 21, 23, 24, 25, 26, 27 and 29 on buff
Varieties 2, 3, 4, 6, 7, 9, 11, 14, 22, 28 and 30 on white
— 6c red, type I
Heads 1 and 16 on white and buff
— 6c red, type II
Head 17 on white and buff
— 6c red, type III
Head 1 on white and buff, used
Head 18 on white
— 6c green, type I
Head 16 on white
Head 1 on buff, used
— 6c green, type II
Head 17 on white and buff
— 10c green, type I
Head 15 on white and buff
— 10c light green, type I
Head 15 on white and buff
— 10c green, type II
Head 19 on white and buff
— 10c light green, type II
Head 19 on white and buff
Reprints, 3c on white and buff
— 6c red on white and buff
— 6c green on white and buff
— 10c on white and buff
- 1857-61, 1c blue, type I, bust points at G
Varieties 1 and 2 on buff
Variety 3 on orange, buff, manila
— 1c blue, type II, bust points between A & G
Varieties 4, 6 and 8 on buff
Varieties 4 and 7 on manila
— 1c blue, type III, bust points at A
Variety 9 on manila
Variety 10 on orange
— 1c blue, type IV, no period after Postage
Varieties 11 and 12 on buff
— 3c red, type I, queue in line with G
Varieties 2, 4 and 5 on buff
Varieties 1, 3, 6 and 7 on white
— 3c red, type II, queue between G & E
Varieties 8 and 9 on white
— 4c red and blue
Variety 4 on buff
— 6c red on white
— 10c green on buff
Reprints, 3c on white and buff
— 6c red on white and buff
— 10c green on white and buff
1861, Narrow die, 3c rose, head A
Varieties 2 and 3 on white
Varieties 1 and 7 on buff
— — 3c rose, head B
Varieties 5 and 6 on white
Variety 4 on buff
— Wide die, 3c rose, head A
Varieties 8, 9, 14; 16 (used) on white
Variety 13 on buff
— — 3c rose, head B
Varieties 10 and 12 on white
Varieties 15 (used), and 17 on buff
Variety 10 on blue

- 6c on white and buff
- 10c green, dark green, blue green and yellow green, on white
- 10c yellow green and pale yellow green on buff
- 10c green and yellow green on salmon
- 12c brown and red on buff and manila buff
- 20c blue and red on buff and manila buff
- 24c green and red on buff and manila buff
- 24c green and violet on salmon
- 40c red and black on buff and salmon
- Reprints, 6c rose on white and buff
- 1863-66, U. S. Postage, 2c black, die A
 - Varieties 1, 2, 4 and 6 on manila
 - Varieties 2 and 5 (used) on buff
 - 2c black, Die B
 - Variety 8 on orange and buff
- U. S. Post, narrow, die C
 - Varieties 1, 3, 5, 7, 12 and 16 on buff
 - Varieties 2, 4, 6, 8, 10, 14 and 15 on manila
 - Varieties 9 and 11 on orange
- Wide, die D
 - Varieties 18, 36 and 40 on buff
 - Varieties 19, 21, 26, 29, 30, 31, 32, 34 and 39 on manila
 - Varieties 17, 24, 25, 28, 33, 35, 37 and 38 on orange
- 1864, 3c rose, die A, head I
 - Varieties 4, 8, 9, 13, 15, 16, 18, 19, 24, 25, 29, 33, 35, 39, 40, 41, 42, 43 and 44 on white
 - Varieties 2, 3, 5, 6, 7, 10, 12, 17, 21, 22, 23, 26, 27, 30, 31, 32, 34, 38, 45 on buff
 - Varieties 1, 11 and 14 on amber
- 3c rose, die A, head II
 - Varieties 46, 48, 51 and 56 on white
 - Varieties 47, 50, 52, 53 and 54 on buff
 - Variety 49 on amber
- 3c rose, die A, head III
 - Varieties 57, 58, 59, 61 (used), 62, 63, 68, 69 and 70 on white
 - Varieties 60, 64, 65, 66, 67 (used), 71 and 72 on buff
- 3c rose, die A, head IV
 - Varieties 73, 74, 76, 77, 81, 83, 85, 86, 88, 91 (used), and 92 on white
 - Varieties 82, 84, 89 and 90 on
 - Varieties 78, 79, 80, 82, 84, 89 and 90 on buff
- 3c rose, die A, head V
 - Variety 95 on buff
- 3c rose, die B, head I
 - Varieties 96 and 98 on white
 - Variety 97 on amber
- 3c rose, die B, head IV
 - Varieties 99 and 100 on white
- 3c brown, die A, head I
 - Variety 31 on buff
- 3c brown, die A, head IV
 - Varieties 80, 83 and 88 on white
 - Variety 73 on buff
- 3c brown, die B, head I
 - Varieties 96 and 97 on buff
 - Variety 98 on amber
- 6c rose, die A
 - Head 1 on white and amber
- 6c rose, die B
 - Head 3 on white and buff
- 6c purple, die A
 - Head 1 on white and buff
- 6c purple, die B
 - Head 3 on white and buff
- 9c yellow, olive yellow and orange on buff
- 12c dark brown, red brown and cinnamon on buff
- 18c vermilion and dull vermilion on buff
- 24c dull blue and greenish blue on buff
- 30c yellow green and blue green on buff
- 40c pink on buff
- 1870-74, Geo. H. Reay, 1c blue, die A on white, orange and amber
 - 1c blue, die B on white, amber, manila and orange
 - 1c dark blue, die B on white and orange
 - 1c ultramarine, die B on amber and manila
 - 2c brown on white, amber and manila
 - 2c red brown on white, amber, manila and orange
 - 3c green on white, amber, salmon and cream
 - 3c dark green on white and amber
 - 3c blue green on white
 - 6c dark red on white, amber and cream
 - 6c red on white and cream
 - 6c bright red on white and cream
 - 7c vermilion on amber
 - 7c vermilion on white (probably faded)
 - 10c black on white
 - 10c brown on white and amber
 - 12c plum on white, amber and cream
 - 12c purple slate on white and cream
 - 15c red orange on white, amber and cream
 - 15c orange on white
 - 15c yellow orange on cream

- — 24c purple on white, amber and cream
- — 30c black on white, amber and cream
- — 90c carmine on white, amber and cream
- 1874-76, Plimpton Mfg. Co., 1c, die A, dark blue on white, amber, manila, cream and orange
- — 1c, die A, light blue on orange
- — 1c, die A, blue on manila
- — 1c, die B, blue on white, amber, orange and manila
- — 1c, die B, pale blue on white amber and orange
- — 1c, die B, dark blue on amber, orange and manila
- — 1c, die B, light blue on orange
- — 2c, die A, brown on white, amber and manila
- — 2c, die A, red brown on cream and manila
- — 2c, die A, vermilion on manila
- — 2c, die B, brown on white, amber and manila
- — 2c, die B, red brown on amber and white
- — 2c, die B2, brown on white and amber
- — 2c, die B3, brown on white, orange and manila
- — 2c, die B3, red brown on amber
- — 2c, die C, brown on white, amber and manila
- — 2c, die C, red brown on amber
- — 2c, die C, red on white, amber, fawn, blue and manila
- — 2c, die C, orange red on amber and cream
- — 2c, die C, vermilion on cream and manila
- — 2c, die C2, red on amber, blue and fawn
- — 2c, die C2, pink on white
- — 2c, die C3, red on manila and amber
- — 2c, die D, red on manila
- — 3c, die A, green on white, amber and cream
- — 3c, die B, green on white, amber and cream
- — 3c, die B, dark green on white, amber, cream, fawn and blue
- — 3c, die B, pale green on amber
- — 3c, die C, green on white, used, and amber
- — 6c dark red on white, amber and cream
- — 6c red on white and fawn
- — 6c pale red on white
- — 6c light red on amber
- — 7c red on white and amber
- — 7c dark red on amber
- — 10c, die A, deep brown on amber
- — 10c, die A, light brown on amber and white
- — 10c, die B, deep brown on white and amber
- — 10c, die B, gray brown on white and amber
- — 10c, die B, light brown on amber
- — 12c plum on white, amber and cream
- — 15c yellow on white
- — 15c orange on white, amber and cream
- — 24c deep violet and pale violet on white
- — 24c purple on amber and cream
- — 30c black on white, amber and cream
- — 90c carmine on white, amber and cream
- — 90c carmine on white (specimen)
- Centennial, Hartford die, 3c vermilion on white
- — — 3c red and pale red on white
- — — 3c green and deep green on white
- Philadelphia die, 3c green, deep green on white
- 1879, Specimen sheet showing all the values, sizes and colors of entire stamped envelopes, issued by the Post Office August 1, 1879
- — 5c, die A, blue on white, amber, cream, blue and fawn
- — 5c, die B, blue on white, amber, blue and fawn
- — 5c, die B, light blue on amber
- 1c, die B, dark blue on white, amber and cream
- 1c, die B, blue on fawn
- 1c, die B, light blue on cream
- 1882, 1c, die B, blue and pale blue on blue
- 1c, die B, dark blue on dull orange
- 1c, die B, light blue on dull orange and manila
- 1882-86, 5c brown on white, amber, blue and fawn
- 5c brown lilac on blue
- 1883, October, 2c vermilion on white, amber, fawn and blue
- November, 2c red on white, amber, blue, fawn and manila
- — 4c, die A, green on white, amber, amber manila; manila blue and oriental buff

- — 4c, die B, green on white, amber manila; manila
- 1884, May, 2c brown on white, amber, blue, fawn and manila
- — 2c red brown on amber and fawn
- retouched, 2c red on white, amber, blue and fawn
- 2c brown on white, amber, blue, fawn and manila
- 2c light brown on white, amber and manila
- retouched, two links under right 2, 2c red on white
- retouched, 3 ½ links over left 2,
- 2c red on white
- July, 2c, die A, brown on white, amber, oriental buff, fawn, blue and manila
- — 1c, die B, on manila
- — 2c die B, brown on amber, fawn, blue (specimen)
- — 4c, die A, on white, amber, blue, oriental buff and manila
- — 4c, die B, on white, amber, manila and amber manila
- 1886, 10c deep brown on blue, oriental buff, manila and amber manila
- 10c reddish brown on blue, oriental buff, manila and amber manila
- 10c gray brown on blue, oriental buff, manila and amber manila
- 30c on manila, amber manila, blue and oriental buff
- 90c on oriental buff, manila and amber manila
- 1887-94, 1c blue on white, amber, manila and amber manila
- 1c dark blue on white, amber, manila and amber manila
- 1c pale blue on white
- 1c greenish blue on manila
- 2c, die A, on white, amber, and oriental buff
- 2c, die B, green on white, amber, oriental buff, manila and amber manila
- — — Dark green on white, amber, blue, manila and amber manila
- 2c die B2, green on white, amber, blue, oriental buff, manila and amber manila
- 2c die C, green on white, amber, blue, oriental buff, manila and amber manila
- 2c die D, green on white, amber, blue, oriental buff, manila and amber manila
- 4c carmine on white, amber, blue, oriental buff, manila and amber manila
- 4c pale carmine on amber manila
- 4c rose carmine on white, amber, manila and amber manila
- 5c die A, dark blue on white, amber, blue and oriental buff
- — — Blue on white and amber
- 30c brown on white, amber, blue, oriental buff, manila and amber manila
- 30c red brown on white, amber, blue, oriental buff, manila and amber manila
- 30c yellow brown on white
- 90c purple on white, amber, blue, oriental buff, manila and amber manila
- Albino, 1c on manila
- — 2c on white and amber
- 1893, Columbian, die A. 1c blue on white
- — — 2c deep red violet
- — — 5c gray brown, brown, yellow brown
- — Die B, 1c blue, dark blue and pale blue on white
- — — 2c deep red violet, red violet
- — — 5c gray brown, brown, yellow brown
- — Die C, 1c blue, dark blue
- — — 2c deep red violet, red violet and gray lilac
- — — 10c slate brown
- — Die D, 2c pale red violet and deep violet on white
- — — 5c brown on white
- 1894-95, Printed by James Purcell from Plimpton dies, 1c dark blue, deep blue, blue, bright blue, pale blue on white, amber and manila
- — 1c blue on blue and oriental buff (entire)
- — 2c die B, green on white, amber, oriental buff and amber manila
- — — Pale green on white
- — — Very dark green on amber
- — 2c die B2, green on white, amber and amber manila
- — — Dark green on white
- — 2c die D, green on white, amber, blue and fawn
- — 4c pale red on white and amber
- — — Rose red on white and amber
- — 2c die E, green on white, amber, blue, oriental buff and manila
- — — Dark green on white, amber and manila
- — — Blue green on white
- — — Gray green on white
- (To be continued.)

THE KANSAS CITY ROULETTE.

Early in December 1914, the Postmaster at Kansas City found that he had on hand a number of unperforated sheets of the current 1c and 2c stamps.

These unperforated sheets had been ordered by him for the use of The National Bank of Commerce in that city, and when the bank suddenly stopped using them, the postmaster had no other outlet for them.

There were not sufficient, in the opinion of the postmaster, to return to the Post Office Department at Washington and unperforated, they could not be sold at the stamp window. The size of the sheet (400 stamps) also made it difficult to keep them properly in the safe.

Therefore, in order to put these stamps in such condition that they could be readily sold, the postmaster had the remaining sheets ROULETTED in his office, making them an official issue, though not authorized by the Department at Washington.

The Department, however, took cognizance of the issue and the postmaster was strictly forbidden to issue any more of the 1c and 2c rouletted stamps, or to manufacture any so-called provisional issue. Orders were also given to report the number of 1c and 2c rouletted stamps still on hand.

As however all of the 2c stamps had been sold, and but 4½ sheets of the 1c stamps remained, permission was granted to sell these stamps in panes of 100 or less, over the counter, locally only.

An affidavit covering the important points in regard to this most interesting issue is printed herewith:

CITY OF CHICAGO }
 COUNTY OF COOK } ss.
 STATE OF ILLINOIS }

TO WHOM IT MAY CONCERN:

Before me the undersigned Notary Public, appeared this day E. Hoffman, personally known to me to be said person which deposes as follows:

I am Secretary of the Newfoundland Stamp Exchange and as such have in due course of business received the following letter through the U. S. Mail:

UNITED STATES POST OFFICE First Class

Kansas City, Missouri.

Dec. 7, 1914.

Sir:—

In reply to your inquiry of the 5th inst., will say that a local firm formerly purchased of us unperforated stamps in sheets of four hundred have discontinued purchasing same, leaving us supplied with this stock.

In order to dispose of them the perforation you speak of was executed at this office and is therefore a purely local matter.

Respectfully,

(signed) J. H. Harris, O. W.,

Postmaster.

The above letter relates to regular one and two cent U. S. Postage stamps of the 1914 type, rouletted (not perforated), and this letter proves that stamps thus issued are a regular and bonafide official issue.

I further declare that the stamps which this affidavit accompanies are taken from such original sheets, issued by said U. S. Post Office, Kansas City. They bear our mark on the back of each block which constitutes a formal guarantee on behalf of the Newfoundland Stamp Exchange.

(signed) E. Hoffman.

And said E. Hoffman further acknowledged the foregoing statement to be correct in every respect. Said E. Hoffman further exhibited to me the original letter from the U. S. Post Office, or Kansas City, and I certify that the above is a true and correct copy made from the original.

WITNESS WHEREOF I have hereunto set my name and notarial seal the 16th day of DECEMBER 1914.

(signed) L. B. LINCOLN,

Notary Public.

SEAL

THE POSTAL ISSUES OF AUSTRIA.

BY J. BRACE CHITTENDEN, Ph. D.

(Continued.)



Ill. 73.

Engraved by Tautenheim, Vienna.

From May 15, 1863 until April 18, 1864.

Imperial double eagle, embossed in white in a colored elliptical frame shaded with an irregular elliptical network; above, Kreuzer, below, cliche of value, Perf. 14. No wmk. Illustration 73.

TABLE 14. 1863-1864.

| | | A or B | | C | Cheapest Quotation | |
|-----|-------------------|--------|-----|------|--------------------|--------|
| 17 | 2K. yellow | 3.75 | .63 | — | 1.25S. | .63 K. |
| 17a | citron yellow | 3.75 | .63 | — | — | .63 K. |
| 18 | 3K. light green | 3.00 | .50 | — | 1.25S. | .50 |
| 18a | yellow green | 3.00 | .50 | — | — | .50 |
| 18b | blue green | 6.25 | .50 | 2.50 | — | .50 |
| 19 | 5K. rose | 3.00 | .03 | — | 1.50S. | .03 |
| 19a | light rose | 3.00 | .03 | 1.25 | — | .03 |
| 19b | deep rose | 3.00 | .03 | — | — | .03 |
| 20 | 10K. blue | 6.25 | .08 | 3.75 | 3.00S. | .06 S. |
| 20a | light blue | 6.25 | .08 | — | — | .06 S. |
| 20b | dark blue | 7.50 | .08 | — | — | .06 S. |
| 21 | 15K. yellow brown | 12.50 | .08 | — | — | .05 S. |
| 21a | light brown | 12.50 | .08 | — | — | .05 S. |

Note 1. Three sets are sufficient to illustrate this issue, which printed on uniformly comparatively thick papers, unwatermarked and perforated with the old machines, are as follows:

- A. Clear, sharp impressions.
- B. Clouded, blurred impressions.
- C. Through shining paper.

In the clear impressions, colored details in the central shield and in the wings and feet of the eagle are defined, whereas in the clouded worn plates they disappear and at last become a white blur.

Note 2. Outer lines 2mm. wide may be found on poorly centered specimens as in the previous issues, usually two, but occasionally with one only. They are known on the 2, 5, 10, 15K. values. They are doubtless very scarce indeed and bring fancy prices.

FIFTH ISSUE.

Engraved by Tautenheim, Vienna.

From April 18, 1864 until August 31, 1869.

Same types and plates as in the 4th issue but perf. 9½. Watermarked in the sheet "BRIEF-MARKEN", Wmk. 2, Illustration 74.

BRIEF-MARKEN.

III. 74.

TABLE 15. 1864-69.

| | A or B | C (Wmk.2) | D | Cheapest quotation & variety. |
|----|---------------------------|--------------|----------|-------------------------------|
| 2 | 2K. yellow (4s.) | .63 .15 | 3.15 .75 | — 3.75 .30 Sf. .12 S. |
| 2a | " vert. laid p. | — 37.50 | — — | — — 25.00 C.S.F.'05 |
| 3 | 3K. light green | .50 .09 | 2.50 .45 | 6.25 1.85 .50 .04 G. |
| 3a | " yellow green | 1.25 .12 | — — | — — — .05 S. |
| 3b | " blue green | 1.25 .09 | — — | — — — .05 S. |
| 4 | 5K. carmine | .50 .01 | — — | — — — — |
| 4a | " carmine rose | .30 .01 | — — | — — — — |
| 4b | " dark rose | .30 .01 | 1.50 .05 | — 1.00 .18 Sf. .01 |
| 4c | " light rose | .75 .01 | — — | — — — — |
| 4d | " violet rose | .75 .01 | — — | — — — — |
| 4e | " vert. laid p. | — 87.50 | — — | — — — 5.00 C.S.F.'05 |
| 5 | 10K. blue | .75 .04 | — — | — — — — |
| 5a | " light blue | 1.00 .04 | 5.00 .20 | — 1.00 .56 Sf. .04 K. |
| 5b | " dark blue | 1.00 .04 | — — | — — — — |
| 6 | 15K. yellow brown | .87 .02 | 4.35 .10 | — 1.25 .75 Sf. .02 K. |
| 6a | " light brown | .87 .02 | — — | — — — — |
| 6b | " red brown | 1.25 .02 | — — | — — — — |
| 6c | " double sided impression | — — | — — | — — — — |

Note 1. Varieties. The 2K. No. 22 is known (one copy) tete beche. The 5K. No. 24 on blue paper. The 10K. No. 25 halved and used as 5K. valued entire 8.75 (K). All values come with one outerline but are very scarce, bringing fancy prices.

Note 2. The watermark in illustration 74 was first employed in the paper used in this issue consisting of the letters BRIEF-MARKEN covering portions of stamps in each of four rows in the middle of each sheet. The letters are 24mm. high and portions of the same letter frequently appear in four different stamps. In each sheet of 100 stamps about 20 on the average would show traces of the watermark making them five times as scarce as those unwatermarked. Occasionally the paper was printed so all of a letter or enough of a letter to be legible appears on one stamp and such specimens bring fancy prices in Europe. This watermark was used from (1864-1883) appearing exclusively on the fifth issue and on the sixth issue with the exception of the very last delivery in 1883.

Note 3. Envelope stamps corresponding to this issue in design and values were cut and occasionally used for postage stamps and are valued as follows.

| | | | |
|------|------------|------|------|
| IX. | 3K. green | 3.75 | 1.50 |
| X. | 5K. red | 1.75 | 1.00 |
| XI. | 10K. blue | 2.50 | 1.25 |
| XII. | 15K. brown | 3.75 | 1.50 |

So far as known, they were never authorized to be used in this manner but passed the post without subjecting the recipient to postage due charges.

TABLE 16.

Reprints of the Issue of 1863-1864.

Reissue of 1884—2500 sets.

Smooth white paper, white gum, perf. 13, also imperf.

| | | |
|----|-----------------------|-----|
| 17 | 2K. pale yellow | .38 |
| 18 | 3K. light olive green | .38 |
| 19 | 5K. rose red | .25 |
| 20 | 10K. dark blue | .25 |
| 21 | 15K. yellow brown | .25 |

Reissue of 1887—10,000 sets.

Thin smooth white paper, white gum, perf. 10-10 $\frac{3}{4}$, also imperf.

| | | |
|----|--|-----|
| 17 | 2K. yellow or orange (10 $\frac{1}{2}$) | .06 |
| 18 | 3K. yellow green (10 $\frac{1}{2}$ -10 $\frac{3}{4}$) | .06 |

The orange of 1887 is a fanciful color.

Reissue of 1892.

Thin smooth white paper, white gum.

| | | |
|----|---|-----|
| 19 | 5K. aniline rose (10700 copies), (13 $\frac{1}{2}$) | .12 |
| 20 | 10K. blue (10800 copies), (13 $\frac{1}{4}$) | .18 |
| 21 | 15K. light yellow brown (10000 copies), (11 $\frac{1}{2}$) | .25 |

SIXTH ISSUE.



Ill. 75.



Ill. 76.

Designed by Scharf and Breneller.

Engraved by Breneller and Marklowsky, Vienna.

From June 1867 until Oct. 31, 1884.

Bust of the Emperor to right with wreath in a circle of 90 pearls framed in a rectangle ornamented with scrolls; and beneath it the cliché of value; perf. (8 $\frac{1}{2}$ -13).

Watermarked in the sheet Wmk. 2 Illustration 74, until 1883 and Wmk. 3 Illustration 77 (1883-1884).

Four plates for each value and several subtypes of the 5K. in each plate, the first two plates known as coarse beards and the last two plates as fine beards. Illustrations 75, and 76.

TABLE 17. Coarse Beard. Fine Beard.

| | A. p. 9 1/2 | B. p. 9 1/2 | B. * p. 9 | C. p. 10 1/2 | D. p. 12-13 | E. p. Comp. | F. Through shining |
|------------------------|-------------|-------------|-----------|--------------|-------------|-------------|--------------------|
| 27 2K. citron yellow | .50 | .04 | .02 | .01 | | | |
| a " brownish yellow | .06 | | | | | | |
| b " dark orange | .50 | .04 | | | | | |
| c " yellow orange | | .06 | .01 | | 7.50 | 7.50 | .85 |
| d " yellow gold | .75 | .04 | .12 | .01 | 20.00 | 8.75 | |
| e " pale yellow | | .12 | .01 | | | | |
| 28 3K. light green | .60 | .04 | .06 | .01 | | | |
| a " dark green | .60 | .04 | | | | | |
| b " yellow green | 1.25 | .04 | .07 | .01 | 5.00 | .75 | .65 |
| c " blue green | 3.75 | .04 | | | | | |
| 29 5K. carmine | .75 | .01 | | | | | |
| a " rose | .75 | .01 | | | | | |
| b " violet rose | 3.75 | .02 | | | | | |
| c " red | 1.85 | .01 | .05 | .01 | 3.75 | .25 | .45 |
| d " purple red | 3.75 | .01 | | | | | .20 |
| e " pale rose | | .05 | | | | | |
| 30 10K. dark blue | 2.00 | .01 | | | | | |
| b " ultramarine | 2.50 | .01 | .50 | .01 | | | |
| c " sky blue | 2.50 | .01 | 1.25 | .01 | | | |
| d " Prussian blue | 3.00 | .06 | | | 5.00 | 6.25 | .65 |
| e " Indigo blue | | .50 | | | | | |
| 31 15K. yellow brown | 1.25 | .06 | | | | | |
| a " reddish brown | 2.00 | .06 | .18 | .02 | | | |
| b " gray brown | 2.00 | .06 | | | | | |
| c " dark brown | 3.00 | .06 | | | | | |
| d " pale brown | | .12 | | | | | |
| 32 25K. gray lilac | 1.25 | .40 | | | | | |
| a " blue lilac | 1.25 | .45 | | | | | |
| b " brown violet | 1.85 | .50 | | | | | |
| c " red lilac | | .15 | | | | | |
| d " blue gray | | .30 | | | | | |
| 33 50K. brown (p. 12) | 1.12 | .75 | | | | | |
| a " brown (p. 13) | | | | | 62.50 | .75 | 1.25 |
| b " brown rose (p. 12) | 3.00 | 1.25 | | | 5.00 | 2.00 | |

*priced for used copies only.

(To be continued.)

A Detailed History of the General Issues of United States Postage Stamps from 1847 to 1890.

BY

CARROLL CHASE, ARTHUR E. OWEN AND WM. B. SPRAGUE.

Rare Year-dated Town Cancellations.

Three lists of "Early United States Year-dated Cancellations" have already been published—two in the *Philatelic Gazette* (for April 1913 and August 1913) and one in the *American Philatelist* (for June 1914) by one of the writers, but as far as we know no list of later rare year dates has appeared. All year dated postmarks of this country prior to 1857 are rare. For a series of 11 years (1857 to 1867 inclusive) year dates were so commonly included in the postmarks that anything like a complete list is impossible, as hundreds of towns and cities were using them during this period. For some unexplained reason year-dated postmarks almost went out of use after 1867 for several years, for not until 1878 were they again commonly used.

In this article we will attempt to list only those prior to 1857 and from 1868 to 1877 inclusive. A few isolated year dated cancellations that have been noted (used before the issue of postage stamps) are given first. Of these we have seen five as follows:

"Wilkesbarre Aug 31 1796" in brownish black in one straight line

"Reading Pa. Sept 17 1831" in red in the ordinary circular form

"Tallahassee Floa. Jan 3 1839" in red in oval form.

"Pt. Isabel [Texas] Feb 4 1847" in black in two lines

"Brazos [Texas] June 9 1847" in black in two lines.

The later year dated cancellations are put in the form of a table, for convenience. The 1853 New York City postmark was evidently in use only about fifteen days. Seemingly it was only an experiment but we have been unable to find any reason why it was discontinued. We have seen eleven of these postmarks, July 11, 1853 being the earliest and July 25, 1853 the latest. New York did not again use the year-date until 1856 and then only in one or two of the several hand stamps in use at that time. These "1856" New York postmarks have been seen in both black and red. The earliest in black seen being January 5th and the earliest in red April 1st. Rutland, Vt. has also been seen in both red and black in 1856.

We are indebted for new year dates, and earlier dates of those previously noted, since the previous list appeared, as follows. To Mr. John D. Cremer for the "Henderson Ky. June 21 1855," the "Trenton, N. J. Apr 7 1856," the "Sumter S. C., May 21, 1856," the "Burlington Iowa Aug 28 1856" and the "E. Saginaw Mich. Nov. 12 1856." To Mr. R. J. Tarp for the "Marshall, Mich Jan 10 1856", the "Huntsville Ala. Mar. 8 1856", the "Freehold N. J. Sep. 12 1856" and the "Columbus O. Nov. 16 1856".

All the postmarks from 1853 on, are in black except as otherwise noted. The month and day given is the earliest date noted in each year.

Year dated railroad, steamboat and fiscal cancellations are occasionally found during the latter period but are foreign to this list.

This list is still far from complete and the writers will be pleased to add to it any year-dated United States town postmarks prior to 1857 or from 1868 to 1877 inclusive. Those prior to 1857 should be sent to Dr. Carroll Chase, 1050 Park Place, Brooklyn, N. Y., and those later to Mr. Arthur E. Owen, 81 Grove St., Montclair, N. J.

1853

New York Jul 11 to 25 inclusive

1855

Washington D. C. Jun 11
Henderson Ky. Jun 21

Pittsburgh Pa. Aug 19
New Haven Con. Sep 17
Farmville Va. Sep. 28
Ann Arbor Mich. Nov 3
Memphis Ten. Dec 15 (blue)
Newburyport Ms. Dec 21 (red)

1856

All those listed in 1855 and the following

New York Jan 5
 Marshall Mich. Jan 10
 Sonora Cal. Feb 1
 Galveston Tex. Feb 24
 Huntsville Ala. Mar 8 (blue)
 New York Apr 1 (red)
 Trenton N. J. Apr 7
 Ithaca N. Y. Apr. 10
 Syracuse N. Y. May 3
 Nashua N. H. May 16 (blue)
 Richmond Va. May 19
 Chicago Ill. May 20
 Hudson N. Y. May 20
 Augusta Ga. May 21
 Sumter S. C. May 21 (red)
 Helena Ark. May 26
 DuBuque Iowa Jun 2
 St Louis Mo. Jun 2
 Rutland Vt. Jun 5 (red)
 Norwich Ct. Jun 7
 Emira N. Y. Jul 21 (blue)
 Keokuk Iowa Aug 1
 Burlington Iowa Aug 28
 Worcester Ms. Sep 5
 Freehold N. J. Sep 12
 Westchester Pa. Sep 16
 Newark N. J. Sep 17

Rondout N. Y. Oct 7
 Troy N. Y. Oct 12
 E. Saginaw Mich Nov 12
 Columbus O. Nov 16
 Sacramento City Cal. Nov 19
 Rutland Vt. Nov. 26
 Manchester N. H. Dec 17

1868

Glens Falls N. Y. Apr 9
 New Mt. Pleasant Pa. Jun. 19
 Rome N. Y. Jul. 6
 Taunton Ms Jul 19 (green)
 Roxbury Mass Aug 30
 Northampton M— Aug 31
 Newport R. I. Aug 31
 Hanover N. H. Aug 31

1869

Cabot Vt. Jan 12
 Glens Falls N. Y. Jan 14
 Taunton Ms Jan 28 (blue)
 Dushore Pa. May 19 (blue)
 Carey O. Oct. 3 (blue)
 Jacksonville Vt. Nov. 27

1870

Muscatine Ioa. Feb. 25
 Charlestown Mass. Mar. 18 (red)
 Crawfordsville Ind. Mar 24

The list will be continued in the next number.

NEW ISSUE NOTES.

We reprint from the Colonial Journal the following information and list of new British Colonial stamps, issued during the last quarter.

British Guiana—72 cent stamps of the new design have been supplied. The duty and name of colony are printed in singly fugitive brown, the rest of the stamp in doubly fugitive purple.

Cayman Islands—The 3d. stamps are now printed on C. A. yellow paper, and the 10s. stamps on C. A. green paper. Both these values were previously printed on white papers with coloured surface.

Ceylon—The 1 rupee stamps have been printed on the new C. A. yellow paper, and the 5 rupees on C. A. green paper.

Malta—The 1s. stamp is printed for the first time on C. A. green paper; previous supplies were on the white paper with coloured surface.

Through the kindness of Mr. J. B. Leavy we print herewith a copy of the latest circular sent out by the Director of the Universal Postal Union, under date of December 30, 1914, announcing the December distribution.

I have the honor to transmit to you herewith:

1st. On the part of the postal administration of Denmark, 3 specimens of its new postal card with reply prepaid, of 3 ore.

2nd. On the part of the administration of New Zealand, at the expressed request of said administration, 3 specimens of a postal card of 1 penny overprinted "Samoa", for use in the part of the islands of that name under military occupation of the British Government.

3rd. On the part of the administration of Persia, 3 specimens of each of its postage stamps of 1 over 13 shahis and 3 over 26 shahis.

4th. On the part of the administration of Belgium, 2 supplementary specimens of each of its special postage stamps of 5, 10 and 20 centimes, in two series, intended for prepayment of articles in the domestic service.

UNITED STATES.

An Interesting Discovery.

BY BERTRAM W. H. POOLE.

The United States stamps of the period 1890-94 have been so well studied that it would hardly be thought likely that any really important variety could be discovered at this late date. Indeed, to look for anything more exciting than the double transfers which have become so fashionable in recent years would appear to be futile in the extreme and yet, in examining some of the 10c stamps of 1898 a short time ago, I accidentally discovered a variety which is not only of first class importance to specialists, but will probably also be deemed a necessary and collectable variety by every general collector. There are also certain minor points in connection with this issue which, though quite interesting, do not appear to have been mentioned in print before.

The stamps of 1890 are a modest looking set and yet they are of particular interest from many points of view. They were the last set of regular postage stamps manufactured by the American Bank Note Company for the United States government; they mark a distinct period in the history of our stamps on account of their size, which has since been adopted as the standard for ordinary usage; and they were the first series in which any real attempt at uniformity of design was attempted.

The set consisted of eleven different denominations—1c, 2c, 3c, 4c, 5c, 6c, 8c, 10c, 15c, 30c, and 90c—and though the portrait on each is different the series falls naturally into two groups according to the frames. The values 1c, 2c, 3c, 4c, 5c, 6c and 8c form the first group distinguished by the fact that the value in words is arranged in the form of a wavy line of uncolored letters across the bottom of the line. The second group contains the 10c, 15c, 30c and 90c denominations and in these the value, in uncolored letters, is shown on a curved band around the lower part of the portrait medallion. Particular note should be made of the fact that on these four values the shading of the foliate ornamentation around the numerals of value in the lower angles extends across the uncolored line forming the base of the label containing "TEN CENTS" etc.

In 1894 the contract between the United States government and the American Bank Note Company terminated, and the printing of the nation's stamps was entrusted to the Bureau of Engraving and Printing at Washington, D. C. When this change took place the dies, plates, and a large stock of stamps already printed were transferred from the printing establishment of the American Bank Note Company to the Bureau. Before printing fresh supplies the new printers added a small triangular ornament to the upper angles of the design of each value to distinguish their work from that of the previous contractors. So far as the values from 1c to 8c inclusive were concerned this was the only alteration but in the case of the 10c and 15c the colored lines of the foliate ornamentation, referred to above, were removed from the uncolored line below the value in words. On the 50c and \$1 values (which took the place of the 30c and 90c of the previous issue) and the \$2 and \$5 stamps this uncolored line is also perfectly plain. It has generally been supposed that these alterations were made direct on the original dies engraved by the American Bank Note Company but, as I shall show a little later, it would appear more probable that secondary dies were made from the originals and the alterations then made. The transfer rollers by means of which the designs were applied to the printing plates were, of course, made from these secondary dies. The existence of the 2c with three distinct types of corner triangles is proof, to some extent, that the alterations were not made on the original dies.

The next step in the history of these stamps was their appearance on watermarked paper in 1895 though no changes were made in the designs or colors beyond those differences of shade common to most United States stamps.

In 1897 the Universal Postal Union recommended that the colors of those stamps generally used for international postage should be the same in all countries belonging to the Union and the adoption of this recommendation by the United States government led to a change of color in the case of six of the values current in 1898-99. The 1c and 5c were issued in the Postal Union colors of green and blue respectively and to prevent confusion the 4c was changed to rose brown, the 6c to brownish-lake, the 10c to orange brown and the 15c to olive green. So far as the designs were concerned no alteration was made except in the 10c, while in this latter denomination we find the new variety referred to above and one which also seems to prove that the addition of triangles to the Bureau prints was not made on the original dies of the American Bank Note Company. The first of the stamps in orange brown were like those of the preceding set in green and are distinguished by the absence of the colored lines on the white line below "TEN CENTS". At some time during the currency of this stamp a new secondary die was made from the original of 1890 and though the triangles were added to the upper angles the colored lines were not removed from the line below "TEN CENTS". We thus have two distinct types of this 10c stamp in orange brown; type 1 being without the colored lines and type 2 with them. The lines are plain and easily seen without a magnifying glass. Which (if either) is the rarer I cannot say from the small amount of material I have for study. The examination of plate number strips would probably show about when type 2 first came into use.

The U. S. Experimental Papers with 3 mm. Spacing.

It is not often, in these days of specialism and especially block collecting, that a variety in the 20th century issues of the United States escapes the eye of the collector for so long a time as the 1c, 2c and 2c Lincoln on experimental paper spaced 3mm. apart.

The early printings of these stamps were from plates with the narrow spacing, 2mm. and most of the collectors were supplied with them, and having obtained one specimen paid no further attention to the later printings from the widely spaced plates.

In none of the so-called specialists check lists of U. S. 20th century issues are these listed although mention of them was made in Mekeel's Weekly in 1911.

In discussing the matter with Mr. Philip H. Ward, Jr., he remembered a letter on the subject which he had from the Bureau of Engraving and Printing, which we print herewith as of peculiar interest.

BUREAU OF ENGRAVING & PRINTING,

February 23, 1911.

Mr. Philip H. Ward, Jr.,
Phila., Pa.

Dear Sir:—

I am in receipt of your letter of the 19th instant relative to the use of experimental rag paper for printing postage stamps. You state that you have recently run across some stamps printed on rag paper from the star plate, and inquire whether or not a second printing was made on this paper after the star plates were issued, and if so, what denominations and what quantity were printed etc.

In reply to your inquiry I beg to say that there was not a second printing of stamps upon experimental rag paper, but it is found that the star plates were used in finishing up the one and two cent stamps which were printed upon this paper. These stamps were inadvertently placed in the regular stock of stamps of the Bureau, and were forwarded to postmasters in the regular order of business included in packages containing stamps printed upon the regular postage stamp paper. It is impossible to state to what offices they were sent.

Respectfully,

(signed) J. S. Ralph, Director.



Published the 15th day of each month

J. KLEMANN, Jr., Editor.

CLIFTON A. HOWES, Special Contributing Editor.

JOHN A. KLEMANN, Managing Editor.

Staff Writers.

CHARLES LATHROP PACK

VICTOR M. BERTHOLD

J. MURRAY BARTELS

DR. CARROLL CHASE

A. E. OWEN

W. B. SPRAGUE

B. W. H. POOLE

SUBSCRIPTION \$1.00 A YEAR, SINGLE NUMBERS 10c.

Advertising Rates on Application.

NASSAU STAMP CO., Publishers, 118 NASSAU ST., NEW YORK.

VOL. V.

NEW YORK, FEBRUARY, 1915.

No. 2.

EDITORIAL.

Much the most important event of the past month in American philatelic circles is the purchase by the Scott Stamp & Coin Co. of the well known and extensive Krassa stock together with all the rights and interest in and to the Ne Plus Ultra albums and stock books.

In these times of apparent depression in business generally, except of course the necessities, the stability of stamps has again been demonstrated in no uncertain way by this purchase.

On going to press we receive the announcement of the death of Mr. Julius Levy, the Manager of the Empire Stamp Co. of Pennsylvania.

The announcement comes to us with numbing suddenness as it was only a short week before that Mr. Levy was in our office, apparently well.

The loss to the Empire Stamp Company is great, but we cannot help but feel that the loss to the philatelic fraternity is even greater because of his sterling character and business integrity.

We extend our sincere and heartfelt sympathy to his family and business associates, in this their great sorrow.

SHORT NOTES AND NEWS.

The publication of The Philatelic Journal of America has been suspended.

The journal was owned by the Stamp Security Co., a corporation that is retiring from business.

The publication will be resumed as soon as the unusual conditions that now prevail change more favorably.

The editor, Mr. Charles Haviland Mekeel, intends to revive the journal and continue its publication when general business affairs reach a normal state.

In the meanwhile, he will publish as manager of The Stamp Exchange a Bulletin for advertising purposes that will appear occasionally and be sent free to the P. J. of A. mailing list. The Bulletin will be issued in the same form as the journal. This, as well as other publications, will be sent free during the interval to those whose names remain on the subscription list.

To those who desire immediate adjustment of unearned subscription credits on account of the P. J. of A., The Stamp Security Co. offers to fill orders from the list of stamps in The Stamp Exchange Bulletin. Credit for any unearned subscription balances may be deducted from Stamp Exchange approval selections, which will be sent on approval with this in view when such requests are made.

We have been shown by Mr. J. M. Bartels a very interesting cover, with the common 3c rose, 1867. The cover was sent from London to Bermuda, through forwarding agents Middletown & Co., New York. The stamp is cancelled "M & Co. Dec. 18, 1868" in a small black circle. The cover has "2d." blue penciled on it, perhaps postage due.

New Discoveries in Former Issues.

1. Bartels' No. 140a—1863 Issue, 2c black, Knife 12, buff paper, type 5, measuring 160x90. This is the only copy known so far and is now in Mr. Worthington's collection.

2. Bartels' No. 143gg—1863 issue, 2c black, dark manila, vertically laid wrapper, measuring 100x200, the stamp being 32mm. from upper edge. This is likewise a unique specimen.

Chronicle of New U. S. Envelopes.

The numbers are those of the Supplement to Bartels' Catalogue of Entire Envelopes.

A correspondent has shown us a copy of the U. S. envelope 2c Carmine, current issue, Die D, var. 13 on white paper. This type was formerly known as existing only on manila (wrapper). From the specimen the size could not be determined.

| | | | | | | |
|-------|----|------|--------|---------|---------|----|
| 2469 | W. | v.13 | Manila | Carmine | 204x305 | W. |
| 2644a | S. | 5v.2 | White | Green | 160x89 | 87 |
| 2645 | S. | 5v.2 | Amber | Green | 160x89 | 87 |

The New 10 Perforation.

All the denominations from 1c to \$1.00 with the exception of the 50c have now appeared with the new 10 perforation. These are all with the new single line watermark except the \$1.00 which is still issued with the double line watermark, and we are informed will not be issued with the single line watermark until the stamp is printed from the 400 subject plates. The 50c denomination has appeared with the single line watermark, perf. 12, and the new perforation is expected on this denomination in due course.

THE 1 CENT GREEN, 1910, IN SHEETS OF SIXTY.

BY PHILIP H. WARD, JR.

During the early part of October, 1912, I had occasion to visit the City Post Office at Washington, D. C., and was surprised to find that they were selling over the counter the 1 cent dark blue green, head of Franklin, Series of 1910, single lined watermark in complete sheets of sixty; six horizontal rows by ten vertical. Purchasing a few sheets, I found that they were all from the "star" plates, had sheet margins on one vertical and one horizontal side with the usual plate numbers and inscriptions, and that the other two sides were straight edges. Further examination showed that these sheets were without doubt issued by the Bureau of Engraving and Printing in this size for the straight edges had good margins outside of the engraved portions, and could not possibly have been trimmed in this manner from larger perforated sheets.

I returned to the Post Office again, looked over a number of sheets, and from examination was convinced that these Post Office sheets of sixty must have been cut from larger sheets. I was able to locate sheets with margins on the upper and left sides, upper and right sides, lower and left sides, and lower and right sides, proving conclusively that they were cut from a larger sheet. The question naturally confronting me was, had the Bureau engraved sheets of 240 and cut them into Post Office sheets of sixty, or had these been cut from the regular sheet of 400. If however, the latter happened to be the case, I could not account for the eight center rows. I wrote to the Bureau, stated the facts, and asked for information on the subject. The following reply is of interest:

Treasury Department,
Bureau of Engraving and Printing,
Washington, D. C.

October 19, 1912.

Mr. Philip H. Ward, Jr.
Philadelphia, Pa.

Sir:—

Your letter of the 18th instant is at hand, stating that you recently purchased at the Post Office in this City a sheet of 1-cent postage stamps, perforated in a sheet of sixty, (six horizontal rows by ten vertical rows); that you were informed by the clerk from whom you purchased them that they were made in order to use up some sheets that were on hand when the new issue came into use; and that they could not be cut into sheets of 100 on account of the spacing of the stamps on the sheet.

I beg to state that you were misinformed regarding these sheets of stamps as they were issued in sheets of sixty in order to accommodate a maker of stamp affixing machines who desired stamps with certain margins. The central eight rows of a number of sheets were furnished for use in the stamp affixing machines and the remaining stamps comprising six vertical rows on each side of the sheet were issued in the form in which you purchased them.

Respectfully,

(Signed) J. E. RALPH, Director.

Knowing that the Bureau would not furnish stamps for an affixing machine in small quantities, I made further inquiries, and learned that the Washington Post Office had received a good quantity of these sheets in the course of its regular business, and that the entire quantity had been passed through this one office.

Among those I inspected the following plate numbers, all from the "star" plates, were noted: # 5603-5604-5605-5607-5639-5640-5643-5644-5651. I was also fortunate in locating three sheets in a peculiar light pea green shade, the normal being in the dark blue green shade. Two of these sheets were from different corners of Plate 5607, the other from Plate 5651. These were the only variations found. One of these sheets from Plate 5607

is slightly lighter than the other, due I judge to the unevenness in inking the plate.

As far as I can learn, no other collector knew of this find until after all had been sold, and as none have been offered though issued over two years ago, I feel confident that few, if any, were saved outside of my small lot. Twenty-five sheets is a fair estimate allowing for a few that may have been saved by others.

While single stamps cannot be distinguished, nevertheless in sheets this is a most interesting variety, and deserves a prominent place in every specialized collection.

COMMUNICATIONS.

AN APPEAL FOR HELP.

Stamp Collectors Asked to Donate a Few Good Duplicates to Assist Destitute Inhabitants of War Stricken Regions.

The American Nation has responded nobly to appeals from war ridden Europe to assist untold numbers of sufferers. The Red Cross Societies of the various nations received from us substantial support. The dire need of Belgium has appealed strongly to our fellow countrymen, and they have rendered substantial aid. In December a Bazaar held in this city for the benefit of the widows and orphans of German, Austrian and Hungarian soldiers forwarded about \$400.00, the proceeds from the sale of postage stamps donated by collectors and dealers.

Comparatively scant information has appeared in our press concerning the terrible devastations, the wholesale destruction of homes and property wrought in East Prussia, especially during the first six weeks of the war when the larger section of that agricultural district was invaded. The undersigned was recently appointed treasurer of an organization for raising funds to help these unfortunate people of whom hundreds of thousands are destitute and homeless.

The firm, J. M. Bartels Co., will shortly hold an auction sale in which a section will be devoted to the relief of the war sufferers. The entire proceeds without deducting any expenses will be devoted to this noble purpose. Collectors are asked to forward as soon as possible a few good stamps which they will donate for this noble cause.

Should anyone desire to contribute to the Red Cross Society of any specified nation, salable stamps will be accepted for auction sale on the same terms and full proceeds forwarded as directed.

J. M. BARTELS.

The Editor, PHILATELIC GAZETTE:—

The following is a copy of a letter received by one of my correspondents in Nogales in regards to the recently issued Mexican "E. S." surcharges. Should you care to publish it in the GAZETTE do so.

Nogales, Arizona, February 6, 1915.

Mr.

Referring to our to-days conversation, we beg to state that we have submitted to the Postmaster in Nogales, Sonora, Mex. the postage stamps of the old federal issue marked with the stamp "E. S." which you handed us and that the said Postmaster stated to us that the stamps referred to are good for circulation in the State of Sonora.

Yours very truly,

Sonora Bank & Trust Co.,

By W. C. Wiuegar,

Manager.

RV

I find in referring to R. G. Dunn that this bank has a capital of \$100,000 and that its New York correspondent is the National Park Bank.

PHILIP H. WARD, Jr.

SOCIETY NOTES.

The Association for Stamp Exhibitions.

The Association for Stamp Exhibitions will hold its Annual Meeting Monday, March 1st, 1915 at 4:30 o'clock P. M. at the Collectors Club, 30 East 42d Street, New York City, for the purpose of electing Directors and transacting such other business as may be brought before the meeting. Twelve Directors are to be elected, 10 for 3 years and 2 for 1 year.

The Boston Philatelic Society.

The Boston Philatelic Society will hold its Annual Jollification on Feb. 16th which will begin with an informal dinner at the City Club, probably in the new club house at 6:00 P. M. for which there will be a charge of \$1.50 for each one participating. This will be followed by a regular meeting (330th) which will be held in the club room in the Tremont Building at the usual time. Several interesting exhibits have been planned and it is hoped the members will attend and bring a friend.

The Collectors Club.

The Collectors Club has arranged a series of Competitive Exhibitions to take place each month according to the following schedule:

February—U. S. 20th Century.

March—Any one British Colony in America.

April—German Colonies.

May—Any Republic in Central or South America.

June—Any European Country.

September—20th Century, General Collection.

October—Any French Colony.

November—U. S. Adhesives, general issues.

December—Any country or colony in Africa outside of German or French.

Awards will be made according to the following basis:

Completeness shall count 35 points.

Rarity shall count 30 points.

Condition shall count 25 points.

Arrangement shall count 10 points.

Three awards shall be made at the discretion of the Judges whenever the exhibits justify it. These will consist of Certificates (1st, 2nd, 3rd) on which will be inscribed the name of the club, the name of the exhibitor, the country for which the exhibit is awarded and the date of the award.

The winner of the largest number of points at the close of the year will receive the Gold Medal offered by Mr. A. Hatfield, Jr.

On March 10th the Collectors Club will hold its Annual Banquet at Healy's Forty-second Street Grill, in the building with the Collectors Club, 30 East 42d St. Dinner will be served at 7:15 sharp. Tickets are \$2.50 each and may be obtained from any of the Officers of the Club or any New York Stamp dealer.

Out of town collectors who may be in New York at that time will be cordially welcomed.

AUCTION REPORT.

J. C. Morgenthau & Co.—88th Sale.

| Lot No. | | |
|---------|--|-------|
| 33 | U. S., 1875 Reissue, 1c blue (102), block of 6, unused, o. g. | 45.00 |
| 111 | — Canned Fruit Stamp, Kensett 1c green (3284) | 12.25 |
| 160 | Bavaria, 1849, 1Kr. gray black (1), used, | 13.75 |
| 171 | Brazil, 1844, 600r black (13), used, | 26.00 |
| 295 | Puerto Principe, 5c on 5m, rare type (189), used, | 26.00 |
| 297 | — 5c on ½ m blue green, Inverted (190a), used, | 21.00 |
| 298 | — 5c on ½ m, rare type inverted (191a), used on piece of original, | 26.00 |

| | | |
|-----|--|-------|
| 305 | — 3c on 2m blue green (203), used, | 28.00 |
| 306 | — 5c on 3m blue green (215), used, | 46.00 |
| 307 | — 5c on 8m blue green (219), | 62.50 |
| 539 | Guatemala, 1882, 20c, centre inverted, (25a), unused, o. g., | 8.20 |
| 759 | Porto Rico, 1890, 80c yellow green (89), used, | 17.50 |
| 887 | Swaziland, 1889, 10s light brown (8), unused, o. g., | 21.00 |

J. C. Morgenthau & Co.—89th Sale.

Lot No.

| | | |
|-----|--|--------|
| 6 | U. S., 1847, 5c brown (28), used on original with Boston Carrier 1p blue (813), | 21.00 |
| 20 | — 1851, upper left diagonal half of 12c used as 6c (36a) on cover, | 45.50 |
| 27 | — 1857, 5c brown Type II (48), used on original with horizontal strip of four 10c green (50A), | 14.00 |
| 33 | — — 30c orange (53), horizontal pair on cover, | 13.75 |
| 34 | — 1861, August, 10c green (58), used on cover with horizontal pair of 5c buff (67), | 20.00 |
| 67 | — Justice, 1c purple on cover, | 8.50 |
| 86 | Hawaii, 1853, 5c blue on thick white paper (5), used with U. S. 1851, 12c black on cover, | 21.00 |
| 87 | — 1859, 2c black on grayish (16), used, | 20.00 |
| 88 | — — 5c blue (22), used on cover with U. S. 1862, 5c black brown, | 27.00 |
| 97 | Canada, 1852, 6p purple black (5), on cover, | 11.25 |
| 98 | — — 6p purple black, 1855, 10p blue on cover, | 50.00 |
| 99 | — 1855, 10p blue (7), on cover, | 12.50 |
| 110 | New Brunswick, 1851, half of 3p red used as 1½p with 6p yellow (2), to make 7½p rate, on cover, | 27.50 |
| 112 | — — Diagonal half of 6p yellow used as 3p (3b), on cover, | 27.50 |
| 114 | — 1867, diagonal half of 10c vermilion used as 5c (8a) on cover, | 16.75 |
| 117 | Newfoundland, 1857, diagonal half of 8p scarlet used as 4p (8a) on cover, | 36.00 |
| 121 | Nova Scotia, 1851, half of 3p blue used as 1½p with 6p yellow green (6), to make 7½p rate, on cover, | 21.00 |
| 124 | — — half of 6p dark green used as 3p (5a), on cover | 31.00 |
| 137 | Hawaii, 1853, 13c dark red (6), horizontal strip of 3, | 31.50 |
| 178 | — 1864, 13c dull rose (9b), horizontal pair, unused, o. g., | 42.50 |
| 183 | — 1859-65, 1c blue (10), No. 8 in Plate, pen cancelled, | 143.00 |
| 184 | — — 2c blue (13), No. 7 in plate, used, | 37.00 |
| 207 | — — 5c blue (21), No. 2 in plate, with U. S. 1862 5c brown on original | 37.00 |
| 288 | — 1861-69, 2c carmine rose (28a), horizontal pair, unused, o. g., | 15.00 |
| 388 | — Black surch., 12c red lilac (69), used on original, | 17.25 |
| 389 | — — 12c red lilac (69), with strip of three 1c green (55), on piece of original, | 13.00 |
| 390 | — — 12c red lilac (69), used, | 13.25 |
| 419 | — 1893, 2c brown (56a), in a block of 4 with the ordinary, unused, o. g., | 19.75 |
| 421 | — — 5c black blue (58a), unused, o. g., | 11.75 |

J. C. Morgenthau & Co.—90th Sale.

Lot No.

| | | |
|-----|--|-------|
| 63 | Canada, 1852, 6p purple black (5, G 7), used, | 13.90 |
| 68 | — 1857, 7½p green (9), used, | 15.25 |
| 70 | — — 6p violet (13), | 18.75 |
| 106 | Iceland, 1902, 25a yellow brown and blue, inverted (57a), unused, o. g., | 20.50 |
| 153 | Argentina, 1910, 20p (175), used, | 12.50 |
| 327 | Kiauchau, 1906, \$½, \$1, \$1½, \$2½ (30 to 33), used, | 8.25 |
| 377 | Panama, Too Late 1910, 2½c red orange (527), used, | 18.50 |
| 393 | Peru, 1907, 2s blue and black (176), unused, o. g., | 9.20 |
| 458 | Timor, 1902, 6a on 10r green (73), used, | 8.50 |
| 459 | — — 15a on 50r blue (78), used, | 9.60 |

UNITED STATES.

Our numerous specialized books have been recently remade and many recent acquisitions added. Collectors have been agreeably surprised at the **extremely low rates** at which they can buy from us. This applies particularly to the general run of regular earlier issues. It is no trouble to send you selections, they are already to go out to any reliable collector expecting to retain \$2.00 worth at a time. 69 books, each covering a different field, now ready. Our PINK LIST describes each one, also a fine line of

BRITISH COLONIALS

in separate books containing our choicest stock of each country. The **West Indies** and **Australians** are the strongest.

When Remounting

send for the books covering the field on which you are working.

AUCTION SALES

Our next sale is now in preparation. A fine lot of U. S. and attractive foreign stamps. Write for a catalogue.

J. M. BARTELS CO.
99 Nassau Street, New York.

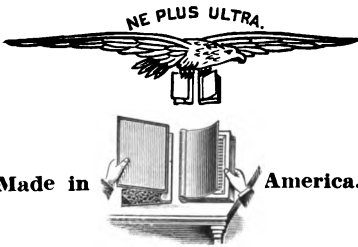

Interchangeable Leaves
Blank Albums **Stock Books**
\$4.00 **\$2.00**
and up. **and up.**

Used by the foremost Collectors and Dealers
 Complete price list free on request



"Ne Plus Ultra" Watermark Revealer
 Price 50c Postage 10c extra.
 All "Ne Plus Ultra" supplies
 Manufactured exclusively by
SCOTT STAMP & COIN CO.,
127 Madison Ave., New York City.

THE
Empire Stamp Co.
 of Pennsylvania
 Announces with deep
 sorrow the
 death of their manager
MR. JULIUS LEVY

THE PHILATELIC GAZETTE

PUBLISHED MONTHLY FOR STAMP COLLECTORS

VOL. V.

NEW YORK, MARCH, 1915.

No. 3.

The United States Government Collection of Postage Stamps.

BY JOSEPH B. LEAVY,

(Continued.)

- | | |
|--|--|
| — — — — Very dark green on white | — — — — brown red, pale brown red and rose on white |
| — — — — 4c bright red on white and amber | — 2c red, variety 3 on white, blue and oriental buff |
| — — — — 5c, die A, pale blue on white and amber. | — 2c die C, pink on white, amber and oriental buff |
| — — — — 5c die B, dark blue on white and amber | — — — — red on blue |
| — — — — — Blue on white | — — — — brown red on amber |
| 1895-97, Hartford, 1c slate blue on white and amber | — 4c die A, brown on white and amber |
| — — — — 1c pale blue on white | — — — — Pale brown on white and amber |
| — — — — 1c greenish blue on manila | — 4c die C, brown on white and amber |
| — — — — spur die, 1c on white and amber | — — — — Pale brown on white and amber |
| — — — — cap on 2, 2c on white and oriental buff | — 4c, error "SIATES" on manila |
| 1899, 1c die A, dark green on white, amber, blue, oriental buff and manila | — 5c dark blue on white and amber |
| — — — — — Green on white, amber and manila | — — — — Blue on white and amber |
| — 1c die B, gray green on white and amber | 1901, 1c olive on white, amber, blue, oriental buff and manila |
| — 1c olive on blue | — — — — green on white, amber, blue and manila |
| — 1c pale olive on white, oriental buff and blue | — — — — pale green on white, amber, blue, oriental buff and manila |
| — 1c deep olive on manila | — — — — deep blue green on manila |
| — 2c die A, pink on white, amber, oriental buff and blue | — — — — yellow green on manila |
| — — — — — carmine on white and amber | — — — — pale yellow green on manila |
| — — — — — pale carmine on white | — 2c red on white, blue, oriental buff and manila |
| — — — — — orange on white and fawn | — — — — pale red on white |
| — 2c die B, pink on white, amber, oriental buff, blue and manila | — — — — deep pink on white |
| — — — — — Orange on white, amber, oriental buff and manila | — — — — pink on white, amber, blue, oriental buff and manila |
| — — — — — Carmine on white, amber, oriental buff, blue and manila | — — — — light pink on white |
| — — — — — red on white, amber, oriental buff and manila | — — — — deep carmine on white and amber |
| — — — — — dull red on white | — — — — carmine on white, blue, oriental buff and manila |
| | — — — — rose red on white, amber, oriental buff and manila |
| | — — — — rose pink on white |
| | — — — — light red on amber |

- — brown red on blue
 — worn die, 2c red and pale red on white
 — recut 2c red
 Variety 1 on white, amber and blue
 Variety 2 on white, amber, blue and oriental buff
 Variety 3 on white and amber
 Variety 4 on white, amber, blue and oriental buff
 Variety 5 on white, amber, blue and oriental buff
 Variety 6 on white, amber, blue and oriental buff
 Variety 7 on white and blue
 Variety 8 on white, amber and blue
 Variety 9 on white, amber, blue and oriental buff
 Variety 10 on white and amber
 Variety 11 on white, amber, blue and oriental buff
 Variety 12 on white, amber, blue and oriental buff
 Variety 13 on white, amber, blue, oriental buff and manila
 Variety 14 on white, amber, blue and oriental buff
 Variety 15 on white, amber, blue and oriental buff
 Variety 16 on white, amber, blue and oriental buff
 Variety 17 on white, amber, blue and oriental buff
 Variety 18 on white and amber
 Variety 19 on white, amber, blue and oriental buff
 Variety 20 on white, amber, blue and oriental buff
 Variety 21 on white and amber
 Variety 22 on white and blue
 Variety 23 on white, amber, blue and oriental buff
 Variety 24 on white, amber and blue
 Variety 25 on white and amber
 Variety 26 on white, amber, blue and oriental buff
 Variety 27 on white, amber, blue and oriental buff
 Variety 28 on white, amber, blue and oriental buff
 Variety 29 on white, amber, blue and oriental buff
 Variety 30 on white, amber and oriental buff
 Variety 31 on white, amber, blue and oriental buff
 Variety 32 on white, amber, blue and oriental buff
 Variety 33 on white, amber and blue
 Variety 34 on white, amber, blue and oriental buff
 Variety 35 on white
 Variety 36 on white, amber and blue
 Variety 37 on white and blue
 Variety 38 on white, amber, blue and oriental buff
 Variety 39 on white, amber, blue and oriental buff
 Variety 40 on white, amber, blue and oriental buff
 Variety 41 on white, amber, blue and oriental buff
 Variety 42 on white, amber, blue and oriental buff
 Variety 43 on white, amber, blue and oriental buff
 Variety 44 on white and amber
 Variety 45 on white, amber, blue, oriental buff and manila
 Variety 46 on white, amber, blue and oriental buff
 Variety 47 on white, amber, blue and oriental buff
 Variety 48 on white and amber
 Variety 49 on white, amber, blue and oriental buff
 Variety 50 on white, amber, blue and oriental buff
 Variety 51 on white, amber, blue and oriental buff
 Variety 52 on white and amber
 Variety 53 on white, amber, blue and oriental buff
 Variety 54 on white, amber, blue and oriental buff
 Variety 55 on white, amber, blue and oriental buff
 Variety 56 on white, amber, blue and oriental buff
 Variety 57 on white and amber
 Variety 58 on white, amber, blue and oriental buff
 Variety 59 on white, amber and blue
 Variety 60 on white, amber, blue and oriental buff
 Variety 61 on white and amber
 Variety 62 on white and amber
 Variety 63 on white, amber, blue and oriental buff
 Variety 64 on white and amber
 Variety 65 on white, amber and oriental buff
 Variety 66 on white and amber
 Variety 67 on white, amber and blue
 Variety 69 on white, amber, blue and oriental buff
 Variety 70 on white and amber
 Variety 71 on white and amber
 Variety 72 on white, amber, blue and oriental buff
 Variety 73 on white and amber
 Variety 74 on white, amber, blue and oriental buff

- Variety 75 on white, amber and blue
- Variety 76 on white, blue and oriental buff
- Variety 77 on white, blue and oriental buff
- Variety 78 on white, amber, blue and oriental buff
- Variety 79 on white and amber
- Variety 80 on white and amber
- Variety 81 on white, amber and blue
- Variety 82 on white, amber and blue
- Variety 83 on white, amber, blue and oriental buff
- Variety 84 on white, amber, blue and oriental buff
- Variety 85 on amber, blue and oriental buff
- Variety 86 on white, amber, blue and oriental buff
- Variety 87 on white, amber and blue
- Variety 88 on white, amber, blue and oriental buff
- Variety 89 on white, amber, blue and oriental buff
- Variety 90 on white, amber, blue and oriental buff
- Variety 91 on white and amber
- Variety 92 on white and amber
- Variety 93 on white, amber, blue and oriental buff
- Variety 94 on white, amber, blue and oriental buff
- Variety 95 on white, amber, blue and oriental buff
- Variety 96 on white, amber, blue and oriental buff
- Variety 97 on white, amber, blue and oriental buff
- Variety 98 on white and blue
- Variety 99 on white, amber, blue and oriental buff
- Variety 100 on white, amber, blue and oriental buff
- Variety 101 on white, amber, blue and oriental buff
- Variety 102 on white, amber, blue, oriental buff and manila
- Variety 103 on white, amber, blue and oriental buff
- Variety 104 on white, amber, blue and oriental buff
- Variety 105 on white, amber, blue and oriental buff
- Variety 106 on white, amber, blue and oriental buff
- Variety 107 on white, amber, blue and oriental buff
- Variety 108 on white, amber, blue and oriental buff
- Variety 109 on white
- Variety 110 on white, amber, blue and oriental buff
- Variety 111 on white, amber and blue
- Variety 112 on white and amber
- Variety 113 on white and amber
- Variety 114 on white, amber, blue and oriental buff
- Variety 115 on white and amber
- Variety 116 on white and amber
- Variety 117 on white, amber and blue
- Variety 118 on white, amber, blue and oriental buff
- Variety 119 on white, amber, blue and oriental buff
- Variety 120 on white and amber
- Variety 121 on white, amber, blue and oriental buff
- Variety 122 on white, amber, blue and oriental buff
- Variety 123 on white, amber, blue and oriental buff
- Variety 124 on amber and oriental buff
- Variety 125 on white, amber, blue and oriental buff
- Variety 126 on white, amber, blue and oriental buff
- Variety 127 on white, amber, blue and oriental buff
- Variety 128 on white, amber, blue and oriental buff
- Variety 129 on white, amber, blue and oriental buff
- Variety 130 on white, amber, blue and oriental buff
- Variety 131 on white and amber
- Variety 132 on white, amber and blue
- Variety 133 on white, amber, blue and oriental buff
- Variety 134 on white and amber
- Variety 135 on white, amber, blue and oriental buff
- Variety 137 on white and amber
- Variety 138 on white
- Variety 139 on white and blue
- Variety 140 on white and amber
- Variety 141 on white, amber and blue
- Variety 142 on white and amber
- Variety 143 on white, amber and blue
- — 2c pink
- Variety 102 on manila
- 2c red, worn die
- Variety 20 on white and amber
- Varieties 48, 83 and 141 on white
- 4c dark brown on amber, and manila
- — light brown on manila
- 5c light blue on white and amber
- Albino, 2c on white and amber
- Double Impression, 2c on manila

- Partial impression, 2c on white
- Exceedingly blurred impression, 2c on white
- Die Proofs in sealing wax, 1c, 2c, 4c and 5c
- 1903, 1c green on white, amber, blue, oriental buff and manila
- — Deep green on white and amber
- 2c, early impression, carmine on white, amber, blue and oriental buff
- — Red on white and amber
- 2c, late, worn impression, carmine on white, oriental buff and manila
- — Red on white and amber
- 4c brown on white and amber
- — Yellow brown on white and manila
- — Black brown on white
- 5c dark blue on white and amber
- Blue on white and amber
- 1907, 1c die A, deep olive on white, amber, blue, oriental buff and manila
- — dark olive on white and manila
- — light olive on white, amber and manila
- — olive on manila
- 1c die B, deep olive on white
- — dark olive on white, amber and oriental buff
- — olive on white, amber, blue, oriental buff and manila
- 2c, die A, red brown on white, amber, blue, oriental buff and manila
- — brown red on white, amber, oriental buff and manila
- — light brown red on white, amber and oriental buff
- — pale brown red on white and amber
- — pale claret on white
- — dull carmine on white and manila
- — carmine on white, amber, blue, oriental buff and manila
- — pink on white and oriental buff
- — light carmine on amber
- — deep pink on amber
- — red on blue, oriental buff and manila
- — dull red on oriental buff
- — deep carmine on oriental buff
- — Worn die, brown red on white
- — light brown red on white
- — dull carmine on white
- — — — carmine on amber and blue
- — — — red on blue
- 2c die A2, carmine on white, amber, blue and oriental buff
- — red brown on white and oriental buff
- — red on white, amber, blue and oriental buff
- — dull carmine on white
- — claret on white
- — pink on blue
- 2c, die B, red brown on white, blue, oriental buff and amber
- — brown red on white, blue, oriental buff and amber
- — light brown red on white, amber and blue
- — pale brown red on white
- — dull brown red on white
- — red on white, amber, blue and oriental buff
- — Worn die, red brown on white, blue, oriental buff and amber
- — brown red on white, blue, oriental buff and amber
- — light brown red on white, amber and blue
- — pale brown red on white
- — dull brown red on white
- — red on white
- — Heavy Impression, light brown red on white
- — dull brown red on white
- — brown red on blue and oriental buff
- 2c die C, carmine on white, amber, blue and oriental buff
- — light carmine and red on oriental buff
- — pink on white and blue
- 2c die E, carmine on manila
- 4c die A, black on white and amber
- 4c die B, black on white and amber
- 5c die A, blue on white and amber
- 5c die B, blue on white and amber
- Albino, 1c die A on white, amber and manila
- 2c die A on white, amber, blue, oriental buff and manila
- 2c die B on white and blue
- Double Impression, 1c, die A on manila
- 2c, die A on white
- Partial Impression, 2c red on white
- 2c pink on white
- Blurred Impression, 2c on white

- Exceedingly Blurred Impression,
2c red on white
1910, 1c olive, die C
Variety 1 on white, amber, blue,
oriental buff and manila
Variety 2 on white, amber and
manila
Variety 3 on white, amber and
manila
— 1c pale olive, die C
Variety 1 on white
Variety 3 on manila
— 2c carmine, die D
Variety 1 on white, amber and
blue
Variety 2 on white, amber, blue
and oriental buff
Variety 3 on white, amber, blue,
oriental buff and manila
Variety 4 on white and blue
Variety 5 on white, amber, blue
and oriental buff
Variety 6 on white, amber and
blue
Variety 7 on white
Variety 8 on white, amber, blue
and oriental buff
Variety 9 on white, amber, blue
and oriental buff
Variety 10 on white and blue
Variety 11 on white, amber, blue
and oriental buff
Variety 12 on white, amber, blue
and oriental buff
Variety 13 on manila
— 2c carmine, die D, heavy impres-
sion
Variety 3 on manila
— 2c pink die D, variety 3 on white
- OFFICIAL ENVELOPES**
War Department, 1873, Geo. H. Reay,
white paper, 1c red, light red
and red brown
— — — — 2c red, light red
— — — — 3c red, light red, red
brown and brown red
— — — — 6c red, brown red
— — — — 10c red, brown red
— — — — 12c red, light red and
brown red
— — — — 15c red, light red,
brown red
— — — — 24c red, light red and
brown red
— — — — 30c red, light red,
brown red
— — — — 1c red on manila
— — — — 2c red on manila
— — — — 3c red, light red on cream
— — — — 6c red, light red on cream
— 1875, Plimpton, 1c red on white,
amber and manila
— — — — 2c red on white, amber
orange and manila
— — — — 3c red on white, cream,
amber, fawn and blue
— — — — Light red on cream and
blue
— — — — Brown red on cream
and blue
— — — — 6c red on white, amber
and cream
— — — — Light red on white
— — — — 10c red on white
— — — — Light red on white
— — — — 12c red on white, amber
and cream
— — — — Light red on white
— — — — 15c light red on white,
amber and cream
— — — — 30c light red on white,
amber and cream
Post Office Department, 1873, Reay,
2c, 3c, 6c on lemon
— 1875, Plimpton, 2c, 3c, 6c on lem-
on
— 1878, 2c black on white
— — 3c black on white and amber
Postal Service, 1878, black on white,
and amber
— — blue on blue
— — dark blue and light blue on
amber
Postal Savings, 1911, 1c olive on ori-
ental buff
— — 2c carmine on white
- DIE PROOFS ON INDIA PAPER**
A set of die proofs made by the Bu-
reau of Engraving & Printing
in 1904
Carrier Stamps, Franklin in blue,
Eagle in blue
- REGULAR ISSUES**
1847, 5c, 10c
1851-57, 1c type I, 3c type I, 5c type
I, 10c type I, 12, 24, 30, 90c
1861, August, 1c, 3c, 5c, 12c
— September, 1, 3, 5, 10, 12, 24, 30,
90c
1862-66, 2c, 3c scarlet, 15c, 24c
1869, 1, 2, 3, 6, 10, 12c, 15c without
frame, 15c framed, 24, 30, 90c
1870, National, 1, 3, 15, 24, 30, 90c
1873, Continental, 2, 3, 7, 10, 12c
1875, 2c vermilion, 5c blue
1882, Re-engraved, 1, 6, 10c
1882-83, 2, 4, 5c
1887-88, 1, 2, 3, 4, 5, 30, 90c
1890-93, 1, 2, 3, 4, 5, 6, 8, 10, 15, 30,
90c
1893, Columbian, 1, 2, 3, 4, 5, 6, 8,
10, 15, 30, 50c, \$1.00, \$2.00,
\$3.00, \$4.00, \$5.00
1894, 1, 2, 3, 4, 5, 6, 8, 10, 15, 50c,
\$1.00, \$2.00, \$5.00
1898-99, 1, 5, 10, 15c

(To be continued.)

UNITED STATES.

Another Interesting Discovery.

 BY JOSEPH B. LEAVY.

The discovery of a new variety of the 10 cent 1898, as explained at length by Mr. Bertram W. H. Poole in the February GAZETTE, aroused my interest to such an extent that I paid a visit to the Bureau of Engraving and Printing and through the courtesy of Mr. Joseph E. Ralph, the Director, was allowed to inspect the dies and furnished with all the data in connection with the variety. Mr. Poole, while deserving all the credit for the discovery of the variety, is entirely wrong in his deductions concerning the original dies of the 1894-98 issue and in some of his suppositions as to secondary dies.

When the Bureau of Engraving and Printing took over the manufacture of stamps for the United States government in 1894, the American Bank Note Company transferred to it the dies for the then current 1890 series, *but no plates or transfer rolls*. The Bureau, in order to distinguish its stamps from those of the American Bank Note Company, engraved a small triangle in each of the upper corners of the dies of the 1, 2, 3, 4, 5, 6, 8, 10 and 15 cents. *No other addition or alteration whatsoever was made to the dies; they are in the vaults of the Bureau to-day, and bear the imprint of the American Bank Note Company.*

Mr. Poole's supposition that the existence of the 2 cent stamp with three distinct types of triangles was proof that secondary dies had been made and the various types of triangles cut upon different or the secondary dies, is only partially correct. Triangles two and three differ from triangle one in having more white space; white space cannot be added to an engraved die, and any additional cutting must print in color, but upon the transfer roll, on which the design is in relief, extra white space may be added by cutting away as many of the lines as is deemed necessary, which is what was done, and from the cut away transfers secondary dies were made with triangle two and triangle three, but triangle one exists only on the recut die of 1890 with the American Bank Note Company imprint.

The dies of the 10c and 15c show the *full foliate ornamentation* surrounding the numeral of value in the lower corners *encroaching* upon the white oval under the words of value. Upon the transfer rolls of the 15c and the first transfer rolls of the 10c the portion of the ornamentation which encroached upon the white oval was cut away, leaving the white oval clear and complete, this being Mr. Poole's type I; the last transfer rolls of the 10c were the same as the die, *without the ornamentation cut away*, this being Mr. Poole's type II, while the 15c never appeared as a finished stamp the same as the die, *but only with the ornamentation cut away*. An examination of the proof sheets of all the plates of the 10c in the records of the Bureau of Engraving and Printing, disclosed the following: Plates 55, 62, 63, 64, 302, 303, 305, 306, 518, 519, 520, 521, and 932, are of 400 subjects, all Mr. Poole's type I. Plates 933, 934, 935, 996, 997, 998, and 999 are of 400 subjects, all Mr. Poole's type II. Plates 1336, 1337, 1338 and 1339 are of 200 subjects, all Mr. Poole's type II. As plate 306 was the last from which the 10c stamp was printed in green, that color exists only in type I. Plates 933, 934 and 935, the first to show type II, were not approved until September 26th, 1899, consequently type II exists only in the various shades of the brown stamp and did not appear until 1900. A die exists of the 10c type I, but it is a secondary die made from the last transfer roll of that type before the roll was destroyed; this die has never been hardened, consequently could not have been used for the manufacture of a transfer.

Mr. J. M. Bartels has informed me that according to his plate number collection the 1898 10c stamp should be arranged according to shades as follows:

Type I. Brown, dark brown.

Type II. Brown, dark brown, reddish brown, deep reddish brown, dull claret brown, yellow brown, deep yellow brown, light yellow brown, orange brown.

Overprinted PHILIPPINES:

Type I. Brown.

Type II. Brown, orange brown.

Transfers were taken by the Bureau of Engraving and Printing from the American Bank Note Company dies of the 30c and 90c, series of 1890, and worked over to manufacture the dies of the 50c and one dollar, series of 1894. The original die of the 50c shows slight traces of the foliate ornaments within the white oval; these traces were all cut away from the transfer and do not appear upon the plate. The original die of the one dollar on the contrary shows the full foliate ornaments of both circles of value encroaching upon the white oval; the encroaching ornaments were cut away upon the transfers and do not appear in the plate. The ornaments were removed in a different manner from at least two of the transfers, and as both transfers were used in laying down the only plate made, *two separate and marked varieties of the one dollar exist*, a fact which I believe has hitherto escaped notice. I have endeavored in the accompanying sketches to illustrate roughly the two varieties.

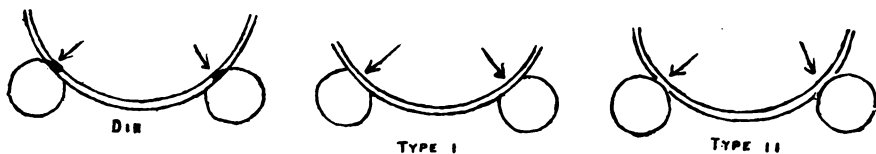

It will be noticed that in type I the lower line defining the white oval cuts the circles containing the numeral of value in such a manner as to give them a concave and incomplete appearance, while in type II this lower defining line is broken on either side of each circle thus giving the circle its complete and rounded appearance. Plate 76, the only plate manufactured of this one dollar value, was of 200 subjects, the left pane showing 100 impressions of type I, the right pane showing fifty impressions of type I and fifty impressions of type II, the last five vertical rows being type II. As plate 76 was the only plate used for the printing of one dollar stamps of this design both varieties exist on paper without watermark, on watermarked paper, the same overprinted Guam, and overprinted Philippines. I have seen them all. Blocks or horizontal pairs or strips from the centre of the right pane would show both types *se tenant*.

The dies of the two and five dollar are in no way different from the stamps as issued.

NEW ISSUE NOTES.

Through the kindness of Mr. J. B. Leavy, we print herewith a copy of the circular sent out by the Director of the Universal Postal Union, under date of February 2d, announcing the January distribution.

1st—*Belgium*: Postage stamps of 5, 10 and 20 centimes of the Red Cross (these stamps are sold at double their face value, and are utilized for the payment of correspondence of the interior service of Belgium);

2nd—*China*: Postal cards of 1 cent (interior service), of 4 cents and 4 + 4 cents (international service);

3rd—*British India*: Postal cards of $\frac{1}{4}$ anna, $\frac{1}{4} + \frac{1}{4}$ anna and 1 anna and stamped envelope of $\frac{1}{2}$ anna, overprinted with the letters I. E. F. (Indian Expeditionary Forces); stamped envelope of $\frac{1}{2}$ anna overprinted with the letters C. E. F. (China Expeditionary Force);

4th—*Netherlands.*

(a) *Curacao*: Postage stamps of 1, 2, 2½, 3, 5, 7½, 10, 12½, 15, 22½, 25, 30, 50 cent, 1½ and 2½ guildens; postage due stamps of 2½, 5, 10, 12½, 15, 20, 25, 30, 40, 50 cents; postal cards of 2½ and 5 cents; stamped envelopes of 5 and 12½ cents;

(b) *Dutch Indies*: Postage stamps of 2, 3, 4, 7½ cents; postage due stamps of 2½, 10, 15, 20, 30, 40, 50, 75 cents; postal cards of 5+5 cents and stamped envelopes of 10 and 12½ cents;

(c) *Surinam*: Postage stamps of 7½, 10, 15, 20, 22½, 25, 30, 50 cent and 2½ guildens; postage due stamps of 2½, 20, 25 and 40 cents; postal card of 2½+2½ cents;

5th—*Portuguese Colonies.*

(a) *Angola*: Postage stamps of 10 and 200 reis with the portrait of Dom Louis, overprinted "REPUBLICA" in red, and surcharged, in black, "115 reis"; 50 reis with the portrait of Dom Louis overprinted "REPUBLICA" in red, and surcharged, in black, "130 reis"; 80 and 100 reis with the portrait of Dom Carlos overprinted "REPUBLICA" in red, and surcharged "115 reis"; 150 reis with the portrait of Dom Carlos overprinted "REPUBLICA" in green, and surcharged "115 reis"; 75 reis with portrait of Dom Carlos overprinted "REPUBLICA" in green, and surcharged "130 reis" in black; 300 reis with portrait of Dom Carlos overprinted "REPUBLICA" in red, and surcharged "130 reis" in black; 2½ reis of the first issue of Dom Carlos overprinted "REPUBLICA" in red, and surcharged "400 reis" in black; 65 reis with the portrait of Dom Carlos (2nd issue), overprinted "REPUBLICA" in red, and surcharged "50 reis" in black (the figures "65" are barred by a line); 50 and 75 reis with portrait of Dom Carlos (2nd issue), overprinted "REPUBLICA" in red and in green respectively, and overprinted in black with the word "Provisorio"; 10, 15, 100, 400 and 500 reis with portrait of Dom Carlos (2nd issue) overprinted "REPUBLICA" in red; 20, 75, 200 and 700 reis with portrait of Dom Carlos (2nd issue), overprinted "REPUBLICA" in green;

(b) *Congo*: Postage stamps of 65 reis with the portrait of Dom Carlos (2nd issue), overprinted "REPUBLICA" in red and surcharged "50 reis" in black (the figures "65" are barred by a line); 50 and 75 reis with the portrait of Dom Carlos (2nd issue), overprinted "REPUBLICA" in red and green respectively, and overprinted with the word "Provisorio" in black; 50, 75 and 200 reis with portrait of Dom Carlos (2nd issue), overprinted "REPUBLICA" in green; 100 reis with portrait of Dom Carlos (2nd issue), overprinted "REPUBLICA" in red.

(c) *Guinea*: Postage stamps of 75 reis with portrait of Dom Carlos (2nd issue), overprinted "REPUBLICA" in red, and further overprinted with the word "Provisorio" in black;

(d) *Lourenzo Marques*: Postage stamps of 10, 200 and 300 reis with portrait of Dom Carlos overprinted "REPUBLICA" in red and surcharged "115 reis" in black; 25, 80 and 150 reis with portrait of Dom Carlos overprinted "REPUBLICA" in red and surcharged "130 reis" in black.

I have the further honor to make known to you, on behalf of the office of the colony of French Oceania, in accordance with ministerial instructions, that all the postage stamps in use in that colony prior to the issue of 1913 were retired from service and payment on December 1st, 1914.

Exception is made of the postage stamps of 15 centimes, as well as the postal cards and stamped envelopes, because these specimens do not exist in the issue of 1913.

After December 1st, 1914, nothing will be available for the prepayment of postage but the large postage stamps (models of three designs) of the issue of 1913, the stamp of 15 centimes and the postal cards and stamped envelopes of the issue of 1893.

Through the kindness of Mr. Gerald D. Bliss, Postmaster at Cristobal, C. Z., we announce the following new issues which were put on sale March 1st.

Canal Zone, 1, 2, 5, 10c

Panama, ½, 1, 2, 2½, 3, 5, 10, 20c.

All are pictorials, printed in two colors, and show scenes in connection with the canal.

BOLIVAR.

The Stamps of 1879-1899.

By A. HATFIELD, JR. and BERTRAM W. H. POOLE.

I.—INTRODUCTION.

To the stamp collector "Bolivar" at once signifies the Department of Colombia of that name so that our title needs no amplification. As a matter of fact another Bolivar—a Province of Ecuador—has achieved some measure of fame (or notoriety) by the issue of stamps and still another Bolivar—a State of Venezuela—occupies more territory, though it apparently has far less ambition in postal affairs. The Bolivar with which we are now concerned is a Department of the Republic of Colombia, bordering on the Caribbean Sea. On the east side are the rivers Magdalena and Cauca and on the west the Sinu, and these, dividing into many channels, irrigate the whole territory to such an admirable extent that rich pasture land is abundant. The chief occupation of the natives is, therefore, cattle raising and many animals are exported annually. The total area of the Department is 21,340 square miles while it has a population well in excess of 300,000. Its capital is Cartagena while its chief port is Barranquilla.

Bolivar, of course, derives its name from Simor Bolivar (1783-1830) "the Liberator," who was born at Caracas, in the Spanish Colony of New Granada, of a noble Spanish family. He was educated at Madrid and after a visit to the United States in 1809 he threw himself heart and soul into the movement for making the colony independent of the mother country. After the abortive insurrection of Caracas in 1810 he proceeded to London; but the British government decided to maintain a neutral policy. Bolivar's party having issued a Declaration of Independence in 1811, a long struggle for the mastery ensued between Spain and her recalcitrant colonists. In 1819 the Congress of Angostura having invested Bolivar with the chief command, he fought the decisive battles of Tunja and Boyaca, and proclaimed the new "Republic of Colombia," which term embraced the whole territory subsequently (1832) divided into the republics of Venezuela, the United States of Colombia, and Ecuador. The war, however, continued until 1821, when it practically concluded with Bolivar's victory at Carabobo. On August 30th, 1821, the constitution of Colombia was adopted and Bolivar was elected President. He next proceeded to effect the independence of Peru, of which country he was chosen dictator (1824), as he was also of Bolivia, freed in 1825. The closing years of Bolivar's life was marked by the unworthy suspicions and intrigues of his co-republicans. But ultimately he was no longer spoken of as a Napoleon, but as a Washington, who had spent his energies and his wealth to secure the liberties of his countrymen. Bolivar, as we have already shown, has given his name to three departments or provinces; Bolivia was named in his honor, several towns bear his name, and he evidently had his admirers in the United States for no less than six villages bear his cognomen.

Naturally his portrait looms large on South American stamps and may be found on certain issues of Bolivia, the republic of Colombia, on most of the stamps of Venezuela and, of course, on nearly all the stamps of the Department we are now discussing.

II.—ITS PHILATELIC HISTORY.

The philatelic history of Bolivar is simple enough, though there is perhaps a good deal of it. The first issue (1863) consisted of a couple of undersized labels of the value of 10c and 1 peso respectively. The former was soon changed in color from green to red, and then the two values sufficed for the postal needs of the Department for eleven years. In 1872 5c, 10c, 20c and 80c stamps were issued, followed, in 1874, by a change in the design of the 5c, and, in 1877, by the issue of a new type for the 10c. In 1878 the 5c was again changed in design, and in the following year an era of constant change was inaugurated. Four

values were issued, all of somewhat similar design and all showing portrait of Simon Bolivar instead of the Arms which had previously occupied the place of honor. In 1880 these values were replaced with new ones, differing only in the date labels at top, and at the same time 80c and 1 peso stamps made their appearance. Both sets are found on blue laid paper as well as the more usual white wove, but it is questionable if the former were all issued for postal use.

In 1882, 5 and 10 peso stamps of extra large size were issued, these standing alone among Bolivar's stamps as the only ones not produced by lithography. These two values were printed from line-engraved plates in two colors and they form a handsome pair. Both denominations are found perf. 16 as well as perf. 12, while the 5 pesos is sometimes found perf. 14 and the 10 pesos is known rouletted.

In 1882 a new set, 5c to 1 peso values appeared, followed in 1883, 1884 and 1885 by precisely similar sets, but with the dates altered. To add that pleasing variety beloved of all good philatelists, each value of all four sets exists perf. 12 all around and compound perf. 16 by 12. After a lull of six years another set was issued, all the values being alike in design and of better execution than previous productions.

The 1891 set did duty until 1903—at any rate no new stamps were issued in the interim—and then we were treated to a ghastly display of how not to produce postage stamps. True, the set consisted of only four values, but as the 50c, 1p, and 2p, were each issued in five colors, and the 10p. in no less than nine colors, and most of these may be found perforated as well as imperforate, they provide more than enough variety. In 1904 low values of even more atrocious design were issued, together with a goodly array of such unnecessary luxuries, as Too Late, Registration, and Acknowledgment of Receipt stamps. Since then Bolivar has ceased to trouble, and we can only hope this happy condition of affairs will continue indefinitely.

It is our purpose in the present article to deal only with the issues comprised in the period 1879-1899—sometimes known as the "Seebeck" issues owing to the fact that they were produced by Mr. Seebeck though whether he had any arrangement with Bolivar on the same plan as that which he made later with the governments of Nicaragua, Salvador, etc., is a mooted point. The earlier issues are of the greatest interest, but, for the present they are omitted as sufficient material for an extended study is not available. The twentieth century issues we have also left to languish "unsought, unhonored, and unsung" for the time being. Possibly a study of these might reveal many points of philatelic interest, and, given sufficient material and energy, much good work might be done in separating the wheat from the chaff, but, as previously stated, we have chosen as our special line of endeavor the issues of 1879 to 1899.

III.—THE 1879 ISSUE.

In January, 1880, the "Philatelic Record" announced the receipt of four new stamps bearing portraits of Bolivar, so we assume they were placed in issue late in 1879. All four values show a profile portrait of General Simon Bolivar, with head to left, on a horizontally lined ground. Though the inscriptions are alike the spandrels differ for each value, and the 40c being intended for use on registry matter, also bears the word "CERTIFICADA" (Registered). Our illustrations show the details of the various designs very clearly so that an extended description is unnecessary. The stamps were produced by lithography and, though Gibbon's catalogue ascribes their manufacture to the Manhattan Bank Note Company, we can find no record as to whether this was the name of Mr. Seebeck's company or not.

All four denominations were printed in sheets of fifty arranged in five horizontal rows of ten stamps each. There was one common die for the portrait, inscribed oval band, and shields for all four values. Separate frames were engraved for each. In the case of the 40c the lower portion of the original design had to be considerably modified to make room for the word "CERTIFICADA." The fact that the four values originated from the same source can be proved by the presence of two small peculiarities. Counting from the left a tiny colored dot follows the first star, on the band immediately below the portrait, and another colored dot partly fills the fourth star. The first of these small dots can be seen quite plainly on all four values, but the second one does not show on the 40c owing to the modification of the lower portion of the design already alluded to.

As is usually the case with stamps produced by lithography, the designs were not transferred to the stone one at a time but in strips. For each value a strip of five transfers arranged vertically was used and these strips were applied to the stones ten times to make the requisite fifty impressions. Again, as is somewhat general under the circumstances, the impressions in each strip of transfers differ slightly one from the other, so that we have five minor types of each value. In each sheet, therefore, the stamps in each horizontal row are alike, the disposition of the types being as follows:

| | | | | | | | | | |
|---|---|---|---|---|---|---|---|---|---|
| 1 | 1 | 1 | 1 | 1 | 1 | 1 | 1 | 1 | 1 |
| 2 | 2 | 2 | 2 | 2 | 2 | 2 | 2 | 2 | 2 |
| 3 | 3 | 3 | 3 | 3 | 3 | 3 | 3 | 3 | 3 |
| 4 | 4 | 4 | 4 | 4 | 4 | 4 | 4 | 4 | 4 |
| 5 | 5 | 5 | 5 | 5 | 5 | 5 | 5 | 5 | 5 |

It would appear that the head and frame dies were always kept distinct so that there was never a complete single die of the whole design for any value. In making up the stones, therefore, one of two methods was employed. Either impressions of the head die were taken five times on the strip of transfer paper and the desired border was then added; or, a single impression of each was taken making a composite of the whole design and from this complete transfer the strip of five was made. It seems probable that the first method was the one employed as we shall show later in referring to the 20c value.

(To be continued.)

THE KANSAS CITY ROULETTE.

We are indebted to Mr. W. C. Michaels for further information in regard to this issue, including copies of the correspondence on the subject, passing between the Third Assistant Postmaster General, the Hon. A. M. Dockery, and Mr. Michaels, which we print herewith in full.

Kansas City, Mo.,
February thirteenth,
Nineteen fifteen.

Hon. A. M. Dockery,
Third Assistant Post-Master General,
Washington, D. C.

My dear Governor:

Besides being a citizen of Missouri, engaged in the peaceful occupation of practicing law, I am, and have been for nearly thirty years, more or less interested in stamp collecting, confining my energies chiefly to assembling what I can of the fifty-five hundred or more varieties issued by our Government. I have never dealt in stamps; I have traded a few, but I do not think I ever sold a stamp in my life.

I did not know anything about the so-called "Kansas City Roulettes" until nearly every one was disposed of by the Post Office here. I have been trying to gather from the various collectors here in Kansas City such information as they have about the rouletting of one-cent and two-cent stamps by the Kansas City Post Office in December last.

I have hesitated about inquiring of the officials here about the matter, since I know from experience that it is oftentimes embarrassing for them to decide what information ought or ought not to be given out.

Therefore, if it is entirely consistent, will you, in aid of correct history of these stamps, give me an outline of the facts about them; for example, what correspondence, if any, took place between the Department and the Kansas City Post Office?

To this day I do not have a copy of the two-cent roulette, but I do have a pair of the one-cent. I suppose, eventually, I will be able to get a pair of the twos.

I am anxious to get now as nearly as possible the dates when these things transpired; whether the rouletting was authorized by the Department or not, or whether the sale of any of the stamps after being rouletted was authorized by the Department, and if so, what stamps and in what amount, and what dates? In other words, I want the information as a matter of history.

I have learned from other gentlemen who are collecting here in Kansas City that they understand that many thousands of these rouletted stamps were sold. But that information is vague, to say the least, and the philatelic public ought to know the whole history of these things.

If there was any order or any correspondence from your office touching the sale of these roulettes, and it is entirely consistent, can you furnish me copies of such orders or correspondence?

You are aware, of course, that there are a very large number of philatelic magazines published in this country, and they, as well as the whole stamp collecting fraternity, all seem to be at utter sea about these Kansas City roulettes; the most absurd statements are being published and stated, and in the interests of clearing up this thing, I think you will agree that authentic data ought to be gathered by some responsible person and given to the stamp collecting public.

I am not interested in any magazine, nor in any dealer, but am solely a collector, but I would like to get this information for the purpose of publishing it in some reliable philatelic paper and thus clear up the whole matter of the "Kansas City Roulettes".

Yours very truly,

(Signed) Wm. C. Michaels.

In your reply refer to

DS 37

234

POST OFFICE DEPARTMENT,
THIRD ASSISTANT POSTMASTER GENERAL.

WASHINGTON, February 25, 1915.

Mr. William C. Michaels,
906 Commerce Bld.,
Kansas City, Mo.

My dear Mr. Michaels:

Upon returning to the Department I find your letter of February 13th in regard to the roulette-perforating of 1c and 2c postage stamps by the Kansas City postoffice, and am very glad to answer your inquiries on the subject.

As you are doubtless aware, the Department issues 1c and 2c postage stamps imperforate primarily for the benefit of users of certain mechanical stamp-affixers and stamp-venders requiring them in that form. It appears that the Kansas City postoffice, having in stock some of these stamps for which the public demand had ceased, perforated them by means of a tracing wheel with a view to making them available for use by the general public. When this perforating came to the notice of the Department the Postmaster was requested to submit a statement concerning it, and I quote from his reply dated December 28, 1914:

"It was found that a very satisfactory perforation could be made with an ordinary tracing-wheel; and sheets of these stamps were in that way perforated from time to time, and placed on sale with the regular stock at the retail stamp windows.

"We have perforated 93,600 1 cent stamps, of which 85,700 have been sold, and have perforated 69,200 2 cent stamps, all of which have been sold."

January 5, 1915, the Postmaster was advised by the Department that there would probably be some demand on the part of collectors for these stamps, and that the remaining 1c "rouletted" stamps should be reserved for such sales, but that not more than 100 should be sold to a purchaser. He was also instructed not to make any special perforations in future without authority from the Department.

Very truly yours,

(Signed) A. M. Dockery,

Third Assistant Postmaster General.

From the above correspondence it will be seen that these Kansas City Roulettes should be given a legitimate status in the catalog, for they show the authority of the Kansas City Post Office to sell the roulettes over the counter, even if they do not show in the first instance that the Kansas City Post Office Officials were authorized to roulette the imperfs.

UNITED STATES—1851 ISSUE.

Dates of First Consignments.

BY J. M. BARTELS.

While in Washington lately I looked into the records of the first shipments of stamps of the 1851 issue as I believe no data on the subject has so far been published. The first consignment of this issue was made June 30, 1851. The record for this day is as follows, the second date being the receipt by the post-master.

| | 1c | 3c | 12c |
|---------------------------|--------|--------|-------|
| June 30, July 1 Baltimore | 10,000 | 20,000 | |
| " " 3 Boston | 20,000 | 40,000 | |
| " " 2 New York | 10,000 | 30,000 | |
| " " 2 Philadelphia | 10,000 | 30,000 | |
| " " 2 Albany | 13,000 | 20,000 | 1,000 |
| " " 3 Buffalo | 10,300 | 20,000 | 1,000 |
| " " 4 Auburn, N. Y. | 300 | 5,000 | 500 |
| " " 5 Bath, N. Y. | 300 | 3,000 | 200 |
| " " 3 Binghamton, N. Y. | 300 | 3,000 | 200 |
| " " 2 Brooklyn | 300 | 5,000 | 500 |
| " " 3 Canandaigua, N. Y. | 300 | 3,000 | 200 |
| July 1, July 1 Washington | 1,000 | 10,000 | |

On July 1, 1c and 3c but no 12c were sent out as follows: New Orleans, Mobile, St. Louis, Cincinnati, Louisville, Hartford, New Haven, Providence, Bridgeport, Norwich, Newport, New London, Springfield, Mass., Worcester, Lowell, Concord, Portland, Me., Augusta, Me., Bangor, Portsmouth, N. H., Rochester, Richmond, Petersburg, Va., Charleston, S. C.

On July 2d, additional 1c and 3c stamps were consigned to Washington, New York and Baltimore; on July 3rd, to Boston, New York, Baltimore and Philadelphia. On July 5th, 29 cities were supplied with 1c and 3c stamps and after that a large number of consignments were made daily.

As shipments of the 12c denomination were far less numerous I give here-with a list of all additional consignments for the first two months:

| | |
|-----------------------------|------|
| July 15 Nantucket, Mass. | 500 |
| " Northampton, Mass. | 100 |
| " Madison, Wis. | 100 |
| July 18 West Meriden, Conn. | 100 |
| " Chapel Hill, N. C. | 100 |
| " Mineral Point, Wis. | 100 |
| July 22 Trumansburgh, N. Y. | 100 |
| " Raleigh, N. C. | 100 |
| " Windsor, N. C. | 100 |
| " Benton, Ill. | 100 |
| " Midway, Ky. | 100 |
| July 25 Lancaster, Pa. | 200 |
| July 26 Livingston, Ala. | 100 |
| July 29 New Orleans, La. | 2000 |
| July 30 Pottsville, Pa. | 100 |

During the month of August 12c stamps were sent in the order named, mostly quite small consignments to the following offices: Quincy, Ill., Bethany, Va., Kenosha, Wis., Columbus, O., Woodville, Miss., Sheboygan, Wis., San Francisco (Aug. 9—40,000), Astoria, Ore. (Aug. 9—10,000), Fairmont, Va. (50), Cannelton, Ind. (50), Monroe, La. (100), Washington, Ohio (50), Washington, Ga. (100), Youngstown, Pa. (50), Wellsboro, Pa. (50), White Hall, N. Y. (200), Sept. 1, Wheeling, Va. (1,000).

From this record it is evident that none of the larger eastern cities received any 12c stamps during the first two months of issue.

This list will be of special interest to collectors in search of early date cancellations.

The 5c and 10c stamps were issued much later but no records of any kind seem to be available.



Published the 15th day of each month

J. KLEMMANN, Jr., Editor.

CLIFTON A. HOWES, Special Contributing Editor.

JOHN A. KLEMMANN, Managing Editor.

Staff Writers.

CHARLES LATHROP PACK

VICTOR M. BERTHOLD

J. MURRAY BARTELS

DR. CARROLL CHASE

A. E. OWEN

W. B. SPRAGUE

B. W. H. POOLE

SUBSCRIPTION \$1.00 A YEAR, SINGLE NUMBERS 10c.

Advertising Rates on Application.

NASSAU STAMP CO., Publishers, 118 NASSAU ST., NEW YORK.

VOL. V.

NEW YORK, MARCH, 1915.

No. 3.

EDITORIAL.

THE question of advertising has been given considerable study and thought in recent years, and the consensus of opinion is that it pays to advertise, a fact which is proven by any one of a score of well known articles which come to mind readily.

The success of these articles, or we might say the advertising was due to three essentials,

First. The offer of a good article.

Second. The use of a good medium to bring that offer before the public, and

Third. The confidence of the public in that medium.

Every advertiser naturally seeks results which in the last analysis is of direct benefit to the three parties interested.

First. The advertiser, who by selling his goods turns over his capital and makes his profit.

Second. The publisher who brings the seller and buyer together through the medium of his publication, producing the results and making profit from increased advertising space and circulation.

Third. The buyer who purchases the goods offered, having confidence in the publication and knowing that the advertisers are reliable and the goods advertised as represented.

There is however, one point which the buyer very often overlooks in answering advertisements and that is to state where the advertisement was seen, especially when the copy runs concurrently in several publications and the advertisement is not keyed. It is this point which we especially wish to bring before our readers in order to show the value of the GAZETTE as an advertising medium, and we feel sure that it will not be asking too much of them to mention the GAZETTE in replying to advertisements.

GARFIELD-PERRY STAMP CLUB.

25th Anniversary Celebration, March 19 and 20, 1915.

Mr. Charles Lathrop Pack's Remarks and Notes Explaining the Stamps Shown by Him at the Meeting.

I have decided to include my exhibits in three oriel binders in place of two. In this way they can be better shown, as three different groups of people can conveniently look at them at the same time.

In attempting to provide some philatelic items worthy of this celebration, I have not tried to get together a lot of rare stamps just because they are rare, but I have rather tried to show some things that may indicate different kinds of philatelic work, as well as some of the recent investigations with which I have busied myself.

Argentine 1888: In Volume I, I have included a study of the Argentine stamps of 1888. Until very recently little has been known about this interesting series. Some things were published in the "Revista," published in Spanish by the Argentine Philatelic Society; and Sr. Jose Marco del Pont also told something about these stamps in his valuable work in Spanish on the stamps of Argentine, but I have found really very little data for the undertaking I have had in hand.

On the pages included in the volume you will find a study of this series worked out according to my ideas. You will note that all these stamps can be plated, and there are a good many interesting things about some of the plates. I am sure they will interest any true philatelist and probably tax his ingenuity if he will undertake further research along the lines which I have undertaken. My work has developed a number of what I believe to be original ideas and made possible still further work, now that a firm foundation has been established. A number of the items shown in this series of stamps I believe to be unique.

Victoria 1850 Three-Pence: Volume II. In this volume, I show a number of items; in the first place my plating of the Victoria three-pence of 1850 as lithographed by Mr. Thomas Ham. I show three reconstructed groups of twelve of these stamps with the proof of the plating.

The sheet of this three-pence, Ham printing, was made up of two separate panes. There were five groups of twelve stamps each in the lefthand pane, and a like number in the righthand pane, making sixty stamps in each pane, or one hundred and twenty stamps in the sheet.

On the 3rd page of my exhibit of this printing of the Victoria three-pence, I show a unique original cover on which there is a block of twelve which happens to include all of the twelve types composing the intermediate stone for this setting. This is the most remarkable cover with the stamps of Victoria that I have ever seen. Before discovering this cover I had worked out the plating by comparisons of pairs and strips. It was indeed a joy to find that the plating made up by this process proved to be exactly the same as the complete block of the twelve subjects on the cover.

In my collection at home in Lakewood I have many pages of pairs, strips and blocks that are studied and explained and which in various ways prove the plating. In addition to this there is an exhibit showing the study of the several retouches of this stamp.

Victoria, Queen on Throne: On Page 5 of this volume is a reconstructed plate of the Victoria two-pence, Queen on Throne of 1854, late impressions in the dull mauve shades. The interesting thing about this plate is that it is completely reconstructed of imperforate pairs.

Later on are two pages explaining the errors of transfer of this stamp. Please note the diagrams showing the location of the errors of transfer. It is the first time so far as I know that this problem has been completely mathematically worked out.

Victoria Two-Shillings 1864: On another page is a reconstructed plate of the printing of the two-shillings value of Victoria 1864, and I am indebted to our friend, L. L. R. Hausburg, Esquire, for help and suggestions. For this printing a smaller plate was assembled of thirty subjects of which eighteen were woodblocks selected from the twenty-five woodblocks used in

the earlier green printing of this stamp. The third, fourth and fifth vertical rows of that setting, with the exception of the lower stamp in the third row (No. 23), were taken intact. For some reason No. 22 was substituted for No. 23. Then these three rows were used as the lefthand half of the new setting. For the top row of the righthand half of the plate, woodblocks Nos. 2, 16 and 17 were selected; and for the remaining twelve subjects electros were made of the corresponding twelve subjects already chosen for the lefthand of the plate. Screws used to fasten these electros to a "backing" in some cases damaged the edges of the electros which defects assisted materially in the plating. A diagram below the reconstructed plate is explanatory.

Victoria 4 Pence Error of Color: On another page in this volume you may be interested in noting the pair of the Victoria 1885 error of color, four-pence, in dull mauve, like one of the shades of the printing of the two-pence. This pair came from the David Hill collection. It is this small lot which Mr. Hill had which caused this variety to be listed by Stanley Gibbons as No. 208A in their catalog. This stamp is excessively rare.

Victoria 1912 Duty Paper: In 1912 in printing the stamps of Victoria they used a so-called duty or revenue paper for a short time during the period when they ran short of the regular paper used for postage stamps. Four values, namely: the onehalf penny, one-penny, two-pence and nine-pence were printed on this duty paper. The watermark is a double lined V over crown, similar to that on paper of the earlier series of 1867-1903. Marginal strips show the watermark words: "Victoria Duty", thus making identification positive, but this paper can be positively identified otherwise. That is why I am showing it here. Please note that the mesh on the duty paper is always at right angles to the device, whereas in the older regular paper it is parallel to the longer axis of the same. This rule serves to identify single specimens. A comprehensive exhibit of strips and blocks of these stamps is shown on six album pages.

Uruguay 240c of 1858: Some years ago Dr. Achillisto Chiesa, a distinguished philatelist of Milan, Italy, owned a complete sheet of the 240 centavos, Uruguay, issued in March 1858. This was the only sheet known. I am sorry to say that after Dr. Chiesa's collection was sold two or three years ago the sheet was cut up and sold by Messrs. Bridger and Kay in sections so that no complete sheet is now extant. Dr. Chiesa was kind enough to send me a photograph in sepia of the entire sheet of this 240 centavos. You will notice in my exhibit a section of the picture of the sheet showing that by means of this photograph I have been able to plate the stamps, and on another page you will notice the reconstructed section of a sheet. No. 23 in each of the first sections and No. 11 in the last row of the sheet are blank, the error 180c red having been removed from these positions. A diagram on the page with the reconstructed section fully explains the makeup of the sheet.

Uruguay One Peso, Arms Inverted: I also show the Uruguay One Peso stamp of 1867 which was prepared in New York under contract with the Government of Uruguay, but the stamp was rejected on account of the arms being reversed. Some South American Philatelists claim that used copies are known but I have never seen one. In any condition the stamp is a rarity.

Uruguay 7c Lithographed 1881: I also think you will be interested on another page in the reconstruction of the varieties of the lithographed 7c Uruguay, issued August 25, 1881. I have published some articles in regard to this stamp and also in regard to the 5c issued April 9, 1884. Some of you may have been good enough to read these articles in the PHILATELIC GAZETTE and other publications. On the page, besides reconstructed strips of these varieties, are diagrams illustrating the details of the different varieties, and also illustrating the makeup of the sheets.

Uruguay, Inverted Center: The 25c Uruguay with inverted center is a stamp of considerable interest to collectors. This was issued during May, 1896. It is an interesting fact that notwithstanding this stamp was used at so recent a date only a very few copies have been found. The variety was not discovered until after all the copies had been used, and unused copies are unknown. A very careful research which I have conducted convinces me that no more than thirty copies of this stamp with the inverted center are known of which you will notice three on one page of my exhibit.

Uruguay 1859: I have recently been re-studying the Uruguay issue of June 1859; the issue with thin lettering. Not very much has heretofore been known about these interesting stamps. We have been helped by the able writings of Dr. Jose Marco del Pont and Mr. Hugo Griebert, but the latter gives very little information in regard to the makeup of these varieties in his book on the stamps of Uruguay. I will not attempt here to describe my discoveries, but I hope you will be interested in examining the album pages. I might say, however, that the stamps of this series were printed from three stones: the 60c and 100c from one stone; the 80c, 120c and 180c from a second stone, and the 240c from a third stone. The same types in the transfers will be found in the same relative positions in the groups composing the sections of the 100c as on the 60c; and likewise the same groups composing the sheets of the 80c and 120c as on the 180c. The stamps of the different denominations mounted in my collection, in comparison each showing a white dot in the southeast spandril, proved this in the case of the last mentioned three values, each being No. 7 in their respective groups, and occurring twelve times on a sheet.

It is probable that the reason three stones were used for this issue, and particular values selected from each one, was owing to the adaptability of the different sets of numerals in making the least labor in altering the stones from one value to another. For instance, assuming that the stone used for the 80c was first prepared, and afterward a supply of the stamps of that value had been printed, then it would have been a simple matter to add 1's to the 80's, making the value read 180c. That such a method was employed is shown by the fact that the eights and zeros are alike in corresponding types of the two values, although each one in a group of twenty is slightly different from another. Having then printed off as many of the 180c as was required an erasure of the 8's and the substitution of the 2's in their place produced the 120c value; and that this value was the last sequence of the three is further shown by the fact that certain transpositions of types were made in this value, as seen in blocks mounted in my collection, which do not appear in either the 80c or the 180c; and furthermore the ones and zeros are alike in corresponding types of the 120c and 180c. In speaking of changes in the stones it must be borne in mind that it was the intermediate stone used in transferring groups of twenty subjects to the large stones from which the printing was actually done, wherein these alterations were made, and although but three of these intermediate stones were used, each of the five values must have been printed from a separate large stone, else all the numerals in the sheet of 204 stamps would have been different had the changes been made on the latter. Also any required after printing of any of the former values would have been impossible had the large stone to be altered.

In this same manner a second intermediate stone was prepared for the 60c and then after having been used for the larger stone of that value the 6's were erased and 10's inserted to produce the 100c value.

For the sixth value of the series, the 240c, it must have been considered easier to make a third intermediate stone rather than undertake the rather extensive alterations required to utilize either of the other two intermediate stones (one reading 120c and the other 100c) neither of which was really adaptable for the use of the 240c value, as in either case two numbers would have to be erased and two new ones inserted in their place; moreover a second erasure would have been required had either been used, and it was evidently deemed impracticable; for although one of the stones had been used to transfer three different values, it will be noted that but one erasure was needed to do this.

The substituted transfers of the 120c are also shown in the collection, as well as diagrams showing the makeup of the regular and normal sheets of all values.

The two covers shown, one with a strip and pair of the 100c thin figures of 1859 and the other with a strip of five of the 120c thin figures of 1859 are both, to my mind, interesting philatelic exhibits. The strip of 120c bears additional evidence of substituted transfers in this series. Both of these covers came from the collection of Dr. Jose Marco del Pont of Buenos Aires, but curiously enough he never seems to have written anything in his valuable contributions to Philately about their unusual philatelic nature and the information which they give us.

Two-Pence First Type of New Zealand and the Retouches: When the New Zealand Philatelic Society were preparing their recently published work on the Stamps of New Zealand one of the officers of the Association secured from the Government of New Zealand some reprints from the old plate of the two-pence of 1863-66. The retouched portions of these reprints were inserted in each copy of the book on the Stamps of New Zealand. I was fortunate enough to receive from a friend in New Zealand a complete sheet of the reprints which for the sake of convenience has been divided. Diagrams on some of the pages of my collection show in a graphic way exactly the portions of the damaged areas on the plate. Some of these damaged areas were retouched but not all. What portions were retouched and what portions were not retouched are shown by the diagrams in connection with my reconstruction of the retouched values. These are shown in the two-pence blue printed when the plate was first retouched in 1867 and the vermilion two-pence printed from the same retouched plate in 1871. I think this exhibit will give some information in regard to these interesting retouches that may not have heretofore come to your attention. My ideas in regard to these stamps are not original, but I have tried to put together in an appealing and graphic form the information that is known by some students of the stamps of New Zealand.

Queensland: Volume III of my exhibit shows a study of certain stamps of Queensland.

You will notice the high values of 1881 in unused condition in reconstructed groups as they were repeated to make up a sheet of 120 subjects. Some of the groups contain ten varieties, and other groups but five.

I could talk for an hour about a study of the 1879-1880 electrotyped stamps of Queensland, the work of William Knight, the Government Engraver. I consider this series of great interest and you are all aware that it contains a number of rarities which are difficult to obtain and are seldom seen. I will not undertake now to explain the many interesting things in regard to this issue, but you will notice that the collection is embellished by drawings and diagrams, showing the makeup of the sheets, the distribution of varieties, the difference in the dies, plates, etc.

This study of the stamps of Queensland 1879-1880, filling an oriel album, was exhibited at the Philatelic Exhibition in London and was awarded a gold medal.

WASHINGTON NOTES.

BY J. MURRAY BARTELS.

On February 26th, the following parcel post and parcel post due stamps were still in the vaults of the Bureau.

| | |
|----------------------|-----------|
| Parcel Post 50c | 283,029 |
| “ 75c | 4,217,949 |
| “ \$1. | 527,219 |
| P. P. Postage Due 1c | 1,482,304 |
| “ “ 5c | 791,644 |
| “ “ 25c | 1,223,364 |

Regular Postage Due 30c stamps have not been printed since 1901 and there are still enough to last a quarter of a century at least. At the present rate of consumption, the 75c Parcel Post and the 25c Due stamps will be enough to last into the 21st century (note this first reference to the latter in the philatelic press). However, it is quite probable that the stock may be destroyed prior to 1950.

The 10 Perforation.

Wide awake collectors knew six weeks ago that the following postage stamps had been issued with the new perforation:

Ordinary, 1, 2, 3, 4, 5, 6, 7, 8, 9, 10, 12, 15, 20, 30c and \$1.00, the latter only double lined watermark; Panama Pacific, 1, 2, 5c; Special Delivery, 10c; Postage Due, 1, 2, 3, 5, 10c; Philippines, 2 cvs. in booklets.

None of the following had been even printed, perf. 10 up to the first of this month: Ordinary 50c, Panama Pacific 10c, Postage Due 30c and 50c. It is not probable that the \$1.00 stamp will appear with the single line watermark. There is still a good supply of the old paper on hand and the \$1.00 stamp will continue to be printed from the small plates with only 200 subjects instead of 400.

It has not been finally decided whether perforation 10 is to become a permanent thing with U. S. stamps. It is however, quite certain that we will not go back to "12". In case the present scale falls to give the satisfaction desired after the sufficiently long test has been made, the wheels may be changed to perforate "11". This would be unfortunate from a philatelic standpoint, but perhaps more desirable for the public. The change from 12 to 10 was made because the sheets did not hold together very well and particularly were poorly adapted for coiling purposes with such weak perforations. Block collectors are much pleased with the stronger perforation.

Unfortunately the centering is frequently very poor and it is quite difficult to find any perfect copies in many of the sheets. We have never seen a sheet in which even 80% of the stamps were perfectly centered.

It is of course, erroneous to believe that the sheets with new perforation were printed on the rotary presses. The only one so far at work has been used exclusively for 1c and 2c stamps coiled horizontally.

The first machines installed to perforate 10 began work on Sept. 4, 1914. Gradually all were changed to this scale and on Nov. 4th the last stamps were perforated old style 12. No records were kept in the interval as to which perforation was used in any individual case. The wheels now in use have 160 pegs perforating 10 (10 holes in two centimeters, an internationally adopted scale) while the old ones had 192. To perforate 11, 16 pegs would be added to the amount necessary to perf. 10. A change to perforate 11 would not be a serious technical matter.

Philippines.

None have been printed or transmitted since last September. The only value out perf. 10 is the 2 cvs. in booklets. Subsequent printings will all be perforated 10. On Aug. 28th, 1914, 800,000 30 cvs. stamps were sent to Manila. As already announced, at least a portion of this lot was printed in gray instead of ultramarine to correspond with the current 15c U. S. stamp.

Revenues.

The Internal Revenue Bureau furnishes the paper for all revenue stamps. They have not changed from the old double lined letters U. S. I. R. as their watermark.

The first work had to be done in an enormous rush to have the stamps ready by Dec. 1st and this is unfortunate as the low denominations were not up to the usual standard of Bureau workmanship. There was not enough revenue paper on hand and for this reason the Int. Rev. Bureau borrowed from the P. O. D. one and a half million sheets with the single line U. S. P. S. watermark and as is well known this was used for printing the recent revenue stamps. Nearly all lower values have been found on the postage paper.

The \$1.00 stamp is printed 300 in a sheet, the \$2.00, \$3.00, \$5.00, \$10.00, \$30.00 and \$50.00 only 200 in a sheet, all later divided into panes of 100. The \$1.00 is therefore $\frac{2}{3}$ the size of the higher values named.

It was our privilege to see also the highest denominations, which are the same size and practically the same designs as the \$100.00, \$500.00 and \$1000.00 stamps of the Spanish War origin. The latter were imperforate while the new ones are not. They are printed as formerly in vertical strips of four attached to stubs bound in books. All are perforated (it seemed to be perf. 12) at left the two center stamps also top and bottom, the first and fourth stamps have two unperforated edges, while all are straight edge at right.

All are printed in one color only as follows:

- \$60.00 (Lincoln) brown
- \$100.00 (Washington) green
- \$500.00 (Hamilton) blue
- \$1000.00 (Madison) orange.

The sheets seen had blank spaces for the insertion of consecutive numbers.

FALSIFICATION OF THE STAMPS OF 20 PESOS, GREEN ISSUE 1891 OF THE ARGENTINE REPUBLIC.

Communicated by Wl. Loescher, Buenos Aires.

During the last months were frequently offered to the Argentine collectors, many stamps of 20 pesos, green, of the issue 1891, and generally at very low prices, which were not in accord with these very scarce stamps.

At first sight we did not suspect them; we supposed that it was the consequence of the general economical position of the country, which obliged many collectors to sell their collections. But shortly, as the offers increased, we began to doubt and thought that these stamps were Specimen-stamps which had been washed and freed from the overprinting "Muestra" and then obliterated with a postmark of the period. However, we lacked the material proof. These stamps, indeed, are of irreproachable aspect, the engraving seems to be untouched, the paper does not show the slightest trace of thinning either with the magnifying glass, in water or in benzine; there seems to be nothing visible of the overprinting, the obliteration occupies a discreet place, and the postmarks employed, correspond perfectly with those which were in use at the time, either for charged letters or for payment of journal postage. There were also offered some pairs and blocks of four, of quite regular aspect, and which appeared exempt from any fraudulent manipulation. In reality, these blocks prove with what artful dexterity the falsifier handled the scratching knife.

I have had occasion to examine a great number, and desiring to prevent this beautiful stamp of the Argentine collection from being discredited by these dangerous products, and in order that European collectors, to whom they will undoubtedly be offered, should be enabled to distinguish them in all cases, I am in a position to indicate, how one can surely recognize them and, I think that I can add without exception.

As it can be seen in the illustration of a block of Specimens, the overprinting "MUESTRA" is printed in a slant on each stamp, in its lower part, and disposed in such a way, that the M. touches the left cipher 20. It can exceptionally happen, that the overprinting is placed higher up; but it is easy to see, that if the overprinting does not touch the left 20 (or the zero) it would necessarily go through the effigy. Now, "the scratcher" was successful in clearing away the overprinting and retouching the signs of his intervention, in those parts of the thick print, but he did not succeed with the retouch of the fine engraving of the cipher 20 and of the face.

First, it seems, he put aside all the Specimens on which the retouch of the face would be necessary, because the defect would have been too visible, and he applied himself exclusively with the more numerous remaining ones; that is, with those, which required only the scratching of the left 20 (or of the zero). But as it was not in his means to redraw the horizontal very fine lines, which give to the left 20 (or the zero) a light green color, it results, that all falsified stamps, could be recognized by this detail, that these horizontal and very fine lines of the left 20 (or of the zero) were lacking all or in part, or that the lines badly retouched, do not appear regularly and plainly drawn as those of the right 20.

In general, knowing this detail and meeting with one of these forged copies, we should be immediately suspicious of the white aspect of the 20 or of a part of this cipher and easily detect the forgery.

The pieces on which the obliteration entirely covered the habitual place of the overprinting, are all suspicious, and require a very particular examination.

The postmarks employed do not give any aid to examination. The forger apparently disposed of several authentic postmark coins of that time. He generally employed a dry, grey ink, whilst those of 1891, generally were oily and thick; but there are numerous exceptions in both cases; as we often may find perfectly authentic pieces with a very clear and grey obliteration, and on the other hand falsified pieces obliterated with an oily and black ink.

The only and unailing way to recognize the falsified copies is that of examining closely the engraving of the left cipher 20.

[We are indebted to Mr. Charles Lathrop Pack, for the above communication, who makes the following comment on the subject:

"I think there is no doubt that some of these copies of the Argentine 20 Pesos, green, of the 1891 issue, which have been cleaned and doctored have reached North America. I do not think, however, that this fraud will extend as far as Mr. Loescher seems to fear for the reason that specimens of this 20 Pesos green with the overprinting, "Muestra" are not common and they have sold for pretty good prices in recent years, even in Buenos Ayres.

I have in my collection a block of four of this stamp without specimen, and a block of four with the words, "Muestra."

Of course it is possible that some unscrupulous person may have come into possession of some sort of a find or discovery of an additional lot of these "specimen" stamps."

EDITOR.]

AUCTION REPORTS.

J. C. Morgenthau & Co.—91st Sale.

Lot No.

| | | |
|-----|--|---------|
| 295 | Papua, 1901, 2s6p bi-colored (8 G 22), unused, o. g., | \$11.25 |
| 313 | Queensland, 1869, Perf. 13x12, 2p blue (49b), unused, o. g., | 9.50 |
| 420 | Victoria, 1850, 3p pale blue (G18), unused, o. g., | 13.50 |
| 422 | — 1854, 2p brown lilac (16), unused, o. g., | 10.70 |

J. C. Morgenthau & Co.—92nd Sale.

Lot No.

| | | |
|------|---|--------|
| 42 | U. S., 1867, Grilled all over, 3c rose (79), used on cover, | 10.60 |
| 43 | — 1869, 30c blue and carmine, (121), used on cover, | 6.25 |
| 70 | Colombian Republic, 1861, 10c blue (16), used on cover, | 15.25 |
| 80 | Bavaria, 1867, 12kr. lilac (19), two used on separate covers, | 10.25 |
| 112 | Nova Scotia, 1860, 8½c green (11a), 5c blue (10), both used on one cover | 16.50 |
| 209 | U. S., Revenues, 1863, Perf., \$200.00. vertical strip of 4, used | 61.00 |
| 215 | — — Proprietary \$1.00, violet paper, unused, o. g. | 115.00 |
| 217 | — — 1899, \$1000, (3045), vertical strip of 4, Nos. 33 to 36, used, | 102.00 |
| 272 | Canal Zone, 1904, 8c on 50c, "CANAL ZONE" inverted (13d, 14d), block of 4, 1 stamp the variety "8", unused, o. g. | 75.00 |
| 333 | Denmark, 1863, 16s violet (10), horizontal pair, used, | 13.50 |
| 471 | Saxony, 1850, 3pf red (1), used, | 44.50 |
| 510 | Gt. Britain, Levant, 1893, 40pa on ½p vermilion (1106), used, | 10.50 |
| 602 | Iceland, 1902, 25a yellow brown and blue (57), unused, | 18.25 |
| 617 | — — inverted surch., 20a blue (56a), unused, o. g., | 31.00 |
| 633 | — — "03-'03" Red surch., 6a gray (46c), unused, o. g., | 11.25 |
| 634 | — — Black surch., 4a rose and gray (51e), unused, o. g., | 12.25 |
| 635 | — — 4a rose and gray (51e), unused, o. g., | 12.50 |
| 636 | — — Perf. 14x13½, 50a blue and carmine (59c), unused, o. g. | 10.10 |
| 648 | — — Pair, one without surch., red surch., 5a yellow green (45), horizontal pair, unused, o. g., | 12.00 |
| 649 | — — Black surch., 5a yellow green, vertical pair, the lower stamp inverted (52a), the upper without surcharge, unused, o. g., | 15.00 |
| 650 | — — 6a gray (53), vertical pair, the lower stamp without surcharge, | 16.50 |
| 651 | — — 10a carmine, horizontal pair, the left stamp without surch., (54b), | 12.50 |
| 677 | Ivory Coast, 1903, 4fr on 60c brown (167), unused, o. g., | 16.50 |
| 682 | — 1906, 4fr on 1f rose, (177), horizontal strip of 3, the middle stamp italic "4" (Koh' 21b), unused, o. g., | 28.50 |
| 771 | New Caledonia, 1892, imperf., 2c brown (14), unused, o. g., | 13.50 |
| 772 | — — 75c carmine on rose (18a), unused, o. g., | 31.00 |
| 1015 | Western Australia, 1854, 2p brown on red (2), used, | 14.10 |



Annual Banquet
of the
Collectors Club,
at the Hotel de Ville, Paris, 1914

ANNUAL BANQUET OF THE COLLECTORS CLUB.

SOCIETY NOTES.

Collectors Club.

The Annual Banquet of the Collectors Club was held Wednesday, March 10th in the Grill Room at Healy's, 30 E. 42nd St., New York City.

The dinner was the most successful in the history of the club, and too much praise cannot be given to the Entertainment Committee, consisting of Messrs. P. C. Hartell, Chairman, W. S. Scott and H. H. Wilson, for the thorough manner in which all the arrangements were made, and which showed a great deal of careful work and preparation on their part.

The menu was carefully selected and the choice of dishes as presented was the work of Messrs. Hartell, Doane and Bird.

For the benefit of those who were not present, and especially to show what they missed we print the full menu herewith.

—MENU—

COCKTAILS

| | | |
|-------|--------------------------------|-----------|
| Bronx | Martini <i>a La Benzine</i> | Manhattan |
|-------|--------------------------------|-----------|

Cotuit Oysters
on Part of Original

SOUP

Cream of Asparagus a la Reine
without O. G.

| | | |
|--------|--|--------|
| Celery | Nuts <i>Strips of Three without Plate No.</i> | Olives |
|--------|--|--------|

FISH

Filet of Sole a la Marguery
Watermarked

Flamingo Tongues
Specimen Omitted

ROAST

Mignon of Filet of Beef, a la Trianon
Grilled All Over

VEGETABLES

| | | |
|--|--|--|
| New Bermuda Potatoes, Risoles <i>1915 Issue</i> | | French Peas, Florette <i>Rare Shade</i> |
|--|--|--|

GAME

| | | |
|--------|-------------------------------------|-------|
| Bridge | Pinochle <i>In the Club Room</i> | Chess |
|--------|-------------------------------------|-------|

SALAD

Hearts of Lettuce and Grape Fruit, Special Dressing
Tete Beche Pair

DESSERT

| | | |
|--|--|------------------------------|
| Fancy Form Ice Cream <i>on Laid Paper</i> | | Cakes <i>Cut to Shape</i> |
|--|--|------------------------------|

Coffee
Slightly Thin

Seventy-one members and their friends responded to our President and Toastmaster, Mr. Wm. Homan, and speeches were made by Rear Admiral Moritz, U. S. N., retired, H. Lippman, Controller, New York Post Office Department, J. M. Fiske, J. C. Morgenthau, J. N. Luff, C. E. Hatfield, E. Goldschmidt, J. M. Bartels, J. B. Chittenden and J. W. Scott. All the speeches were well received and we regret we are unable to print them.

Souvenirs in the form of a Pocket Stock Book were distributed and a photograph of the group was taken, which we reproduce on another page.

Those who were present at the dinner, arranged according to tables, are given in the following list.

| | | |
|-------------------------|--------------------|----------------------|
| Wm. Homan, Pres. | J. W. Scott | Senator Ackerman |
| H. Lippman, Controller | John A. Klemann | E. B. Power |
| P. O. Dept. | J. Klemann, Jr. | J. H. Barnhardt |
| Read Admiral Moritz, U. | E. Goldschmidt | L. B. Mason |
| S. N. Retired. | C. T. Harbeck | W. Driscoll |
| — | S. Singer | D. F. Wheless |
| J. C. Morgenthau | Lester Grimes | J. M. Fiske |
| T. E. Steinway | — | J. Hopkins |
| J. N. Luff | J. M. Bartels | H. Reves |
| T. L. Wells | H. G. Zervas | — |
| A. Scolley | A. Burger | H. M. Clarke |
| P. M. Wolsieffer | G. Burger | J. T. Coit |
| C. G. Dietrich | Ed. Stern | A. Krassa |
| — | M. Costella | W. S. Scott |
| V. Mozian | T. Burdette | H. H. Wilson |
| F. Stedman | — | J. S. Rich |
| J. Monhib | M. Ohlman | C. E. Hatfield |
| A. Chah Moorat, Tenor | E. Weiss | J. W. Russell |
| French Opera Co. | H. Schmidt | — |
| — | S. R. Simmons, Jr. | H. E. Robinson |
| J. C. Damm | D. Pick | H. M. Rau |
| C. L. Wichelman | A. Keller | A. Reed, Pres. B. T. |
| C. Ploch | — | Babbit Soap Co. |
| C. F. Zorn | F. W. Hyde | D. Richardson |
| R. P. Levis | H. Seymour | Dr. J. B. Chittenden |
| Arthur Levis | J. B. Frolke | J. Beam |
| R. C. Hess | L. W. Charlat | P. C. Hartell |
| | J. M. Bird | |

The next meeting will be held Wednesday evening, March 24th at 8:00 P. M., and the Competitive Exhibition arranged for the evening is "Any British Colony on the Western Hemisphere".

Association for Stamp Exhibitions.

The Annual meeting of the Association for Stamp Exhibitions was held Monday, March 1st, 1915, at the Collectors Club, 30 E. 42d St., New York City.

The meeting was called to order at 4:30 P. M., with Mr. J. C. Morgenthau, the President, in the chair.

The minutes of the previous meeting were approved as read.

The chairman reported that it had been decided to perpetuate the organization and make the dues \$1.00, payable annually, and that an application for a charter for a College of Philately had been made to the State Board of Regents by Mr. H. M. Lewy, the attorney for the Association.

The President also announced the death of Mr. Julius Levy, a former director of the Association, which was received with deep regret.

The Secretary reported that the membership at the close of the Exhibition was 749 members of which there were 135 active members on March 1st.

The Treasurer reported a balance of \$856.42 in the treasury.

Mr. John Klemann, the chairman of the Auditing Committee, reported that the accounts of the Treasurer from the beginning to and including May 1, 1914, had been audited and printed.

The President appointed Messrs. Klemann, Mason and Ploch to audit the books to March 1st, 1915.

The following Directors were elected:

Directors to serve 3 years.

J. H. Barnhardt
C. Gregory
W. H. Hendrickson
E. Klein
J. N. Luff

L. B. Mason
H. C. Needham
B. Schlesinger
J. W. Scott
G. R. Tuttle

Directors to serve 1 year.

H. M. Clark

A. Hatfield, Jr.

As there was no further business, the meeting adjourned.

At the Meeting of the Board of Directors, which met immediately after the Annual Meeting the following officers were elected: President, J. C. Morgenthau; Vice President, A. E. Owen; Secretary, J. A. Klemann; Treasurer, J. W. Scott.

The election of the Executive Committee resulted as follows:

J. C. Morgenthau
A. E. Owen
J. A. Klemann
J. W. Scott
H. M. Lewy
J. N. Luff
T. L. Wells
T. E. Steinway

W. S. Scott

On motion duly made and seconded, Mr. Batchelder was elected to fill the vacancy caused by the death of Mr. Levy.

As there was no further business, the meeting adjourned.

Garfield-Perry Stamp Club, Cleveland, Ohio.

On March nineteenth and twentieth the Garfield-Perry Stamp Club will celebrate its twenty-fifth anniversary.

On Friday evening, March nineteenth, a regular meeting of the Club will be held at the Colonial Hotel, for which an especially interesting program has been arranged.

Of unusual interest to both members and guests, will be the presence of Dr. Carroll Chase, of New York City, who will exhibit his remarkable collection of 1847, 1851 and 1857, and will tell of the progress he has made in the study of these issues.

On Saturday afternoon open house will be held at the Colonial Hotel, at which several important collections, including sections from the collections of Mr. Worthington and Mr. Pack will be exhibited.

The Anniversary will officially close with the banquet on Saturday evening. The committee has arranged a program that should make the banquet even more successful than that held on the Club's twentieth anniversary.

The Garfield-Perry Stamp Club, organized March 17, 1890, has had twenty-five years of activity. Its regular meetings having been held without a single interruption, its membership showing a constantly increasing growth, until today it is one of the largest clubs in the country.

As the entire program will be carried out at the Colonial Hotel, it is suggested that out-of-town guests make this hotel their headquarters, where they will be assured of every attention.

Staten Island Stamp Society.

In commemoration of the Sixth Anniversary of the Staten Island Stamp Society there will be a Kommerz at the club rooms, Van Duzen and Prospect Streets, on Tuesday evening, March 16, 1915, at 8 P. M.

New York Stamp Society.

Meetings: 1st and 3rd Thursday of every month, Tuxedo Hall, Madison Ave. and 59 St.

Next Exhibit, April 1, 1915, United States 20th Century.

Mr. Edgar L. Green will exhibit his collection of Finland also.

The Kansas City Philatelic Society.

The Kansas City Philatelic Society, which continues to grow right along, now has a local organ through which its campaign for a larger membership is to be carried on. "The Central Philatelic," published by Ralph L. Ward, 2028 North Tremont Street, Kansas City, Kas., has appeared, No. 1, Vol. 1, and is a neat appearing, well edited entrant to the field of philatelic journalism. Mr. Ward is a teacher in the Kansas City, Kas., high school and owns his own printing plant and does practically all of the work on his publication himself and feels reasonably well satisfied that his publication will continue. The subscription price is 50 cents a year.

Members of the Kansas City Philatelic Society will give him every encouragement. They are endeavoring to build up one of the largest local societies in the country. New members are being taken in at every meeting and attendance at the meetings runs all the way from 20 to 40. Auction sales are held at every meeting and this does much to attract attendance.

The club probably has one of the finest meeting places of any club in the country, having use of the rooms of the Midday Club on the fourteenth floor of the Commerce Building in the heart of the city.

The next meetings of the club will be held April 2, April 16, April 30, May 14, May 28. The last meeting for the season probably will be held in June. Regular auction sales will be held April 2, April 30, May 28 and at the last meeting for the season in June.

HARRY F. KOHR.

REVIEW.**Kohl Briefmarken Handbuch und Grosser Katalog. (10th Jubilee Issue)**

This new edition of the Kohl catalog has again established itself as the most thorough catalog issued, and as its name implies is a handbook on stamps containing information which can only be obtained from vast experience and extensive reading and study.

Much material is crowded between its covers in the most condensed form with reference to the authority on the subject in case more information is desired by the reader.

All of the countries have been thoroughly revised and brought up to date in accordance with the latest information and discoveries, and in many cases entirely re-written.

To aid the collector of used stamps illustrations of bogus cancellations, where such exist, are given, and their points of detection noted.

A complete list of specimen stamps is also included for the first time, together with prices.

With the inclusion of this new material every field of philatelic endeavor appears to be well represented and covered in the most thorough manner, making it a most valuable reference book for the advanced collector and specialist.

Part I, Europe and Colonies, XXXII + 1535 + X pp., illustrated, with index and addenda. Bound in cloth.

Part II, balance of the world, XVI + 675 + X pp., illustrated, with index and addenda. Bound in cloth. Paul Kohl, Chemnitz, Germany, Publishers. Price for both volumes \$4.15 net.

Used 20th Century British Colonials,
including values up to 10s. in beautiful condition.
Unused 20th Century British Colonials
Unused and Used 19th Century British
Colonials.

Comprise the principal part of our April Sale.

This is a beautiful collection formed in Europe and is undoubtedly the finest lot of used 20th century ever sold at auction in this country.

The balance of the sale consists of U. S., some odd and rare things in Venezuela and a section, the total proceeds of which go to War-sufferers of Europe.

Catalogues ready shortly. Are you on our mailing list?

J . M . B A R T E L S C O .
99 Nassau Street, New York.

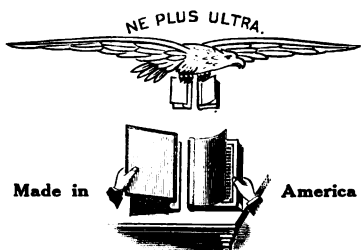

Interchangeable Leaves

BLANK ALBUMS - \$4.00 and up
STOCK BOOKS - \$2.00 and up

Used by the foremost Collectors and Dealers
Complete price list free on request



"Ne Plus Ultra" Watermark Revealer
Price 50c. Postage 10c. extra

All "Ne Plus Ultra" supplies manufactured exclusively by
SCOTT STAMP & COIN CO.
127 Madison Ave. New York City

93rd SALE

MARCH 30 and 31, 1915
Includes Fine a Lot of Puerto Principe

94th SALE

APRIL 14th and 15th 1915
United States and Foreign
Catalogues mailed on request.

J. C. Morgenthau & Co.
87 Nassau St., New York City.

Locals and Carriers

What have you to offer?
Send at your lowest cash price.

JOHN A. KLEMANN
118 Nassau St. New York

A GENUINE WAR PRICE OFFER.

Everything in different, genuine stamps only, to the surprise of the purchaser in beautiful combination—

2200 all different postage stamps Value over fcs. 500 for fcs. 100 or Marks 84

My Finest offer, I can recommend the purchase to all my patrons. This means a real War offer. I can not sell sets for which the dealer pays 5F and the collector 8F. any cheaper, but when I offer a whole collection I can add many surprises, figured at cost price for two reasons. 1st for advertisement and 2nd to enlarge my sales during the war. I am therefore sure that each purchaser will bring me additional clients. Anyone can order this collection with the utmost confidence.

CONTENTS.

- Australia, Kangaroos & dues
 Argentine, many issues, very fine
 Antioquia, rare ones
 Austria, war stamps, also Levant
- Bosnia, fine, Jubilee & War stamps
 Belgium, present issues
 Baden, Officials
 Bolivia, very fine
 British Guiana
 Barbados, very nice
 Bulgaria, good
- China, very nice, including surch & dues
 Chile, very nice lot
 Ceylon, many
 Cyprus, also a few
 Cuba, especially the new issues
 Costa Rica, 1900, 1, 2, 5, 10, 20, 50c, 1, 2, 5, 10 Colones, 1907, the fine 20, 25, 50c, 1, 2 Colones, which few collections contain, also good provisionals
- Danish West Indies
 Dominica, a few varieties
- Ecuador, nice, used copies
 Egypt, the new issues
- France, War stamps, many Colonies such as Dahomey, Mauritania, Senegal, New Caledonia, Madagascar, etc.
- Greece, including many Crete
 Guatemala, from the parrot issue to the latest surcharges
 Gold Coast
 Great Britain
- Hayti, also a few
 Haiderabad
 Honduras, many varieties
 Hungary, 6 War stamps
- Iceland, good
 Indora, only better ones
 India, the British ones
 Italy, very nicely represented
- Jamaica, many copies
 Jhind, much sought for
- Leeward Islands, very nice
 Liberia, 50 varieties, Cash value F40
 Luxemburg
- Monaco
 Malay States, very good
 Mexico, many, also 1884, 50c, 1, 2 Peso
 Montenegro, 1907 complete, valuable set to 5Kr. also complete Postage due, and R. R.
 Mozambique Company, 1894-1902, Coat of arms, 2½-1000 Reils, all lightly cancelled, a beautiful set for any collection.
- New Zealand, very nice
 New South Wales, everybody likes them
 North Borneo, 1909, the beautiful set, 1-24c; 1903 complete, the best postage dues, 2-24c
 Norway, Jubilee, also others
 Netherlands, very good
 New Foundland, good
- Persia, many and nice, such as 1900, 1-16 Chahi; 1-50 Kran, fine set, all used
 Peru, very good
 Panama, nicely represented
 Porto Rico, very interesting
 Paraguay, also good
 Portugal, a few very nice ones, also Nyassa, 3 rarities examined by Thier & Schlesinger, catalog value of these 3 alone at least 40F.
- Russia, all 4 War stamps, and Russ Levant and a rarity of Russ Crete
 Roumania, good, for instance 1906 Exposition, large shape, 5-75 bani, 1.50, 2.50, 3L, everything fine
- Servia, also fine, including a guaranteed genuine Error, value 20F
 Southern Nigeria
 Salvador
 Switzerland
- Transvaal, 1892, £5 mint, face value \$25.00. Catalog value very high, 1894, mint, ½-10sh, rarities of the first order
- Trinidad, good
 Turkey, Surprise, 1914, Adrianople surcharge, very rare, the complete set, the rare red provisional Postage due issue, only 4 days in use, the complete set also
- Venezuela, specialties

**Catalog value over F500. 2200 different Postage Stamps.
 Price 84 Marks, Post paid.**

BELA SZEKULA, Luzern, (Switzerland)

THE PHILATELIC GAZETTE

PUBLISHED MONTHLY FOR STAMP COLLECTORS

VOL. V.

NEW YORK, APRIL, 1915.

No. 4.

The United States Government Collection of Postage Stamps.

BY JOSEPH B. LEAVY,
Philatelist, U. S. National Museum.

(Continued.)

- Die proofs on India paper (continued)
- 1898, Omaha, 1, 2, 4, 5, 8, 10, 50c, \$1.00, \$2.00
- 1901, Pan-American, 1, 2, 4, 5, 8, 10c
- 1902, 1, 2, 3, 4, 5, 6, 8, 10, 13, 15, 50c, \$1.00, \$2.00, \$5.00
- 1903, 2c
- 1904, Louisiana Purchase, 1, 2, 3, 5, 10c
- 1907, Jamestown, 1, 2, 5c
- Special Delivery, 1885, 1888, 1893, 1894, 1902
- POSTAGE DUE**
- 1879, 1, 2, 3, 5, 10, 30, 50c
- 1891, 1, 2, 3, 5, 10, 30, 50c
- 1894, 1, 2, 3, 5, 10, 30, 50c
- OFFICIAL STAMPS**
- Agriculture Dept., 1, 2, 3, 6, 10, 12, 15, 24, 30c
- Executive Dept., 1, 2, 3, 6, 10c
- Interior Dept., 1, 2, 3, 6, 10, 12, 15, 24, 30, 90c
- Justice Dept., 1, 2, 3, 6, 10, 12, 15, 24, 30, 90c
- Navy Dept., 1, 2, 3, 6, 7, 10, 12, 15, 24, 30, 90c
- Post Office Dept., 1, 2, 3, 6, 10, 12, 15, 24, 30, 90c
- State Dept., 1, 2, 3, 6, 7, 10, 12, 15, 24, 30, 90c, \$2.00, \$5.00, \$10.00, \$20.00
- Treasury Dept., 1, 2, 3, 6, 7, 10, 12, 15, 24, 30, 90c
- War Dept., 1, 2, 3, 6, 7, 10, 12, 15, 24, 30, 90c
- NEWSPAPER STAMPS**
- 1865, 5, 10, 25c
- 1875, 2, 3, 4, 6, 8, 9, 10, 12, 24, 36, 48, 60, 72, 84, 96c, \$1.92, \$3.00, \$6.00, \$9.00, \$12.00, \$24.00, \$36.00, \$48.00, \$60.00
- 1885, 1c
- 1894, 1, 2, 5, 10, 25, 50c, \$2.00, \$5.00, \$10.00, \$50.00, \$100.00
- CONFEDERATE STATES—
GENERAL ISSUES**
- 1861, Hoyer & Ludwig, 5c deep gray green, deep green, green, light green
- — 10c dark blue, blue
- — 10c dull blue, block of four
- 1862, Hoyer & Ludwig, 2c green
- — 5c dark blue, pale blue
- — 5c blue, block of four
- — 10c rose
- Patterson, 10c pale blue, pale greenish blue
- 1862, London Print, 5c milky blue, pale blue
- — 5c light blue, block of four
- — 1c orange, block of four
- Local Print, 5c dark blue, thin paper
- — 5c dark blue, thick paper
- 1863, Archer & Daly, Ten Cents, milky blue
- — 10c milky blue, outer line
- — India paper, 2c brown red, pale brown red
- — 2c deep brown red, block of four
- — 10c bright blue, die A
- — 10c bright blue, milky blue, die B
- — Thin bond paper, 10c milky blue, greenish blue, pale blue, pale gray blue, die A
- — 10c deep blue, die B
- — 20c green, yellow green, bright yellow green
- 1864, Keatinge & Ball, 10c indigo, deep blue
- — 10c dark blue, block of four, die A

- — 10c deep blue, die B
- — 20c dark green
- — 20c blue green, block of four

UNITED STATES POSSESSIONS

CUBA—PUERTO PRINCIPE

1898, Surcharge 18mm Vertically

- 1c on 1m orange brown
- 2c on 2m orange brown, type I
- 2c on 2m orange brown, type II, used
- 3c on 2m orange brown, type I
- 3c on 3m orange brown, type I
- 3c on 3m orange brown, type II, used
- 5c on 1m orange brown, type II, used
- 5c on 1m orange brown, type II, used
- 5c on 2m orange brown, type I, used
- 5c on 3m orange brown, type I, used
- 5c on 3m orange brown, type II, used
- 5c on 5m orange brown, type I, used
- 5c on 5m orange brown, type II, used
- 5c on ½m blue green, type I, used
- 5c on ½m blue green, type II

Inverted surcharge, 2c on 2m orange brown, type I, used

- 2c on 2m orange brown, type II, used
- 3c on 3m orange brown, type I, used
- 5c on 1m orange brown, type I, used
- 5c on 1m orange brown, type II, used
- 5c on 5m orange brown, type I, used
- 5c on ½m blue green, type I, used

1898-99, Surcharge 20mm Vertically

- 1c on 1m orange brown
- 3c on 1m orange brown, type I, used
- 3c on 1m orange brown, type II, used
- 5c on ½m blue green, type I, used
- 5c on ½m blue green, type II, used
- 5c on 2m blue green, type II, used
- 5c on 4m blue green, type I, used
- 5c on 8m blue green, type I, used
- 3c on 1m blue green, type I, used
- 3c on 1m blue green, type II, used
- 3c on 2m blue green, type I, used
- 3c on 2m blue green, type II, used
- 3c on 3m blue green, type I, used
- 3c on 3m blue green, type II, used
- 3c on 1c black violet, type I
- 3c on 1c black violet, type II
- 5c on 1c black violet, type I
- 5c on 1c black violet, type II
- 10c on 1c black violet, strip of five

Inverted surcharge, 3c on 1m blue green, type II, used

Inverted surcharge, 3c on 1c black violet, type I, used

- 1c on 1m orange brown, used
- Error, cents for cents, 3c on 1m blue green, type I, used

- 1899, 1c de p on 1c yellow green
- 2c de p on 2c carmine, red
- 2½c de p on 2c carmine, red
- 3c de p on 3c purple
- 5c de p on 5c blue
- 10c de p on 10c light brown
- 5c de p on 5c blue, Cupa for Cuba
- Inverted surcharge, 2c de p on 2c carmine, unused
- Set complete, 1c de p to 10c de p handstamped Specimen in small type
- 1c yellow green
- 2c carmine, scarlet
- 3c purple
- 5c blue
- 10c brown
- Set complete, 1c to 10c, handstamped Specimen in small type

— Complete set, 1c to 10c die proofs on India paper

Postage Due, 1, 2, 5, 10c deep claret

- 1, 2, 5, 10c deep claret, handstamped Specimen in small type

Special Delivery, 10c de p on 10c dark blue, block of four, one without period

- 10c de p on 10c dark blue, handstamped Specimen in small type
- 10c orange
- 10c orange, handstamped Specimen in small type

STAMPED ENVELOPES

1898, 1c de p on 1c green on blue and oriental buff

- 2c de p on 2c green on white and amber

- 2c de p on 2c carmine on amber and blue

1899, 1c green on white, amber, blue, oriental buff and manila

- 2c carmine on white, amber, blue, oriental buff and manila
- 2c pink on white and amber
- 5c dark blue on white and amber
- 5c light blue on white

GUAM

- 1899, 1c green
- 2c carmine
- 3c purple
- 4c lilac brown, orange brown
- 5c blue, deep blue
- 6c magenta
- 8c puce
- 10c yellow brown, type I
- 15c olive
- 50c orange
- \$1.00 black, type I
- \$1.00 black, type II
- Set complete, 1c to \$1.00, handstamped Specimen in small type

- Special Delivery, 10c blue
 — 10c blue, handstamped Specimen in small type
 — 10c indigo, special printing

PORTO RICO

- Coamo, 5c black on white
 1899, 1c yellow green
 — 2c carmine
 — 5c blue
 — 8c puce
 — 10c yellow brown, type I
 — Set complete, 1 to 10c, handstamped Specimen in small type
 1900, Puerto Rico, 1c yellow green
 — — 2c carmine
 — — 3c purple
 — — 8c puce
 — 10c yellow brown, type I
 — — Complete set, 1 to 10c handstamped Specimen in small type
 Postage Due, 1899, 1, 2, 10c deep claret
 — — 1, 2, 10c deep claret, handstamped Specimen in small type
 — 1900, Puerto Rico, 1, 2, 10c deep claret
 — — — 1, 2, 10c deep claret, handstamped Specimen in small type

STAMPED ENVELOPES

- 1899, 2c green on white
 — 5c blue on white
 — 2c rose on white, rose overprint
 — 5c blue on white, blue overprint
 — Puerto Rico, 2c rose on white
 — — 5c blue on white
 — Puerto Rico large, 1c yellow green on oriental buff and blue
 — — 2c rose on oriental buff and blue
 — Porto Rico, 4c brown on white, die C

PHILIPPINES

- 1894, No watermark, 50c orange
 — Watermarked double line U S P S, 1c yellow green
 — — 2c carmine, red
 — — 3c purple
 — — 5c blue, deep blue, dark blue
 — — 10c brown
 — — 15c olive
 — — 50c orange, red orange
 — — Set complete, 1c to 50c, handstamped Specimen in small type
 1901, 4c orange brown, yellow brown, lilac brown

- 6c brownish lake, deep brownish lake
 — 8c violet brown, deep violet brown
 — 10c yellow brown, type II
 — \$1.00 black, type I
 — \$1.00 black, type II
 — \$2.00 dark blue
 — \$5.00 deep green
 — Special printing, \$1.00 black, type I
 — — \$2.00 blue
 — — \$5.00 dark green
 1903-04, 1c green, yellow green, gray green
 — 2c carmine, carmine rose
 — 3c purple
 — 4c brown, orange brown, pale orange brown
 — 5c blue, deep blue
 — 6c brownish lake, light brownish lake
 — 8c violet black
 — 10c orange brown, dark orange brown
 — 13c dark violet brown
 — 15c olive
 — 50c orange
 — \$1.00 black
 — \$2.00 deep blue
 — \$5.00 dark green
 — 2c carmine, rose carmine, scarlet
 — Special printing, 1c to \$5.00 complete set
 — Error, 2c carmine, Peilippines
 — — 2c carmine, Pilippines
 1906, wmkd. double lined P I P S,
 — — 2c green, deep green
 — — 4c carmine, rose carmine, scarlet
 — — 6c violet, deep violet
 — — 8c brown
 — — 10c blue, dark blue
 — — 12c brown lake
 — — 13c violet black, black violet
 — — 20c orange brown
 — — 26c violet brown, deep violet brown, deep gray violet
 — — 30c olive
 — — 1 peso orange
 — — 2 pesos black
 — — 4 pesos blue, dark blue
 — — 10 pesos dark green
 1909, 2c yellow green
 — 4c carmine lake
 — 10c light blue
 — 12c red orange
 — 16c olive
 — 20c yellow
 — 26c blue green
 — 30c ultramarine
 — 1 peso pale violet
 — 2 pesos violet brown
 1911, wmkd. single line P I P S,
 — — 2c green

(To be continued.)

NEW SOUTH WALES TWO-PENCE LAUREATE, PLATE II of 1853.

A PLATING DISCOVERY BY CHARLES LATHROP PACK.

In the pair of stamps in my specialized collection of New South Wales, an illustration of which accompanies these notes, lies the proof of an error in the published plating of Plate II, of the two-pence value, stars in corners, as shown on illustration "I" of "The Postage Stamps, etc., of New South Wales," by A. F. Bassett Hull, London 1911, published under the auspices of the Royal Philatelic Society.



No. 33

No. 34

The lefthand stamp agrees in every minute detail with the type illustrated as No. 33 both on the reconstructed plating (Illustration "I") and on the cut of the sheet of reprints (Illustration "J"); while the *right-hand stamp* is wholly unlike the No. 34 on the reconstructed plating, though agreeing with that type on the plate of reprints.

An investigation with comparisons of types shows that the plated number 34 on Illustration "I" referred to is merely a duplicate of type eleven, and that the correct number, 34, on the plate is not shown at all, except as it appears in worn condition on the "reprints."

I was much interested in the discovery of the error of the plating in Plate I of the two-pence, Laureate, a corrected illustration of which has just been received from the London Publishers of Mr. Hull's valuable book. Oddly enough, this No. 34 has always been a stumbling block, the illustration being poor and indistinct. But when the new illustration of No. 34 was recently received from London a comparison with my plating disclosed that the plating in my collection of the two-pence, Plate I, was correct, agreeing with the new illustration, or cut sent for that position. How this result was obtained, neither Mr. Louis G. Barrett nor myself can say at present, but with the very large amount of material that has been in our hands there must be pairs, etc., which give the correct details. The cut of No. 34 in the New South Wales book shows a double-topped S to the word, SOUTH, in the upper label, which peculiarity we have never been able to find in any of the material that has passed through our hands. We have thought that the cut in the New South Wales book must have been made from a poorly repaired specimen (as it probably was), and in our plating we disregarded the feature of the double-topped S entirely.

It is curious that it should have been No. 34 in Plate II, instead of No. 34 in plate I, which we first (although we are not certain which was first) found to be in error. Here then is the possibility that the party who originally plated the values from which the book illustration was made was a victim of a "continuing" error; carrying on certain details from Plate I to his plating of Plate II, whence naturally it would follow that if No. 34 were wrong in Plate I, as now is shown, the same number in Plate II would be wrong likewise, whereas if he had consulted carefully the "reprint" sheet his error in the latter would have been plain.

It seems rather strange that we should have discovered the error in Plate II last year, and that No. 34 in Plate I was correctly placed in our plating the year before the illustration was recently received from London.

A Detailed History of the General Issues of United States Postage Stamps from 1847 to 1890.

By

CARROLL CHASE, ARTHUR E. OWEN AND WILLIAM B. SPRAGUE.

ALTERATIONS OF THE NATIONAL BANK NOTE CO.'S DIES OF THE 1870 SERIES OF UNITED STATES POSTAGE STAMPS.

With notes relative to plate varieties of the printings by the National, Continental and American Bank Note Companies.

Since the announcement, in 1895, of the discovery of certain "secret marks" on the stamps of the Series of 1873 printed by the Continental Bank Note Co., numerous articles descriptive of them have appeared in the philatelic press, but a recent investigation by the author shows that while in most particulars the details of these marks as described and illustrated in the catalogues and handbooks are correct, there are a number of points of interest, which it is believed have never before been described, and which are of importance to the student of United States stamps issued between 1870 and 1883.

It is generally conceded that the stamps engraved and printed by the National Bank Note Co. in the period from 1861 to 1873, are superior in every way, with the possible exception of the gum used, to any other issue of United States postage stamps, and in the preparation of the plates it is evident that they exercised great care. Notable "shifted transfer" varieties, which are numerous in the '51-'56 and '73-'82 series, are not to be found, and in the few "shifted transfers" in the National Co.'s issues, the duplication of design is very slight and generally can only be found by the use of a magnifying glass.

Some of the National Co.'s dies of the 1870 series show minor defects of engraving, such as background shade lines extending into the colorless ellipse surrounding the portrait medallion, and other slight errors of this character, but these were generally removed from the transfer roll, and consequently were not reproduced in the plates. A background line extension on the die proofs of the 30 ct. stamp of this issue was believed to be a "secret mark" made by the Continental Bank Note Co., and described as such in an article published in the "Metropolitan Philatelist" on Nov. 18th, 1911, but subsequently, other sets of die proofs, unquestionably printed from the original dies of the National Co. and from the dies as altered by the Continental Co. have been examined, and the conclusion reached that the mark existed on the original National Co.'s die, and is not a "secret mark" of the Continental Co.

Through the courtesy of Mr. J. E. Ralph, Director, Bureau of Engraving and Printing, at Washington, D. C., an examination of the original dies of the National, Continental and American Bank Note Co.'s, and of the Bureau of Engraving and Printing, of the Series 1870-1882, has recently been made, and at this inspection it was ascertained that all of the original National Co.'s dies of the 1870 series bear the imprint of that Company; that when the "secret marks" were placed on these dies by the Continental Co. in 1873 it was done without their being softened, and that the marks are poorly executed and not deeply cut owing to the hardness of the steel; and that when further alterations were made in 1881 by the American Bank Note Co. on the 1, 3, 6 and 10 cent dies, it was done after they had been softened. Further details on these points will be given in the following descriptions of the individual dies.

ONE CENT.

The die block of the one cent stamp is 3 in. high, 2.50 in. wide and about 0.20 in. in thickness. The stamp design is placed equally distant from the sides of the block, the top of the design being 0.80 in. from the top of

the block, and the bottom of the design 1.20 in. from the bottom of the block. The imprint, "National Bank Note Co. N. Y." is in condensed light faced capital letters which slant slightly to the left. The corners of the block are rounded, and the upper edges beveled. This beveling gives to some die proof impressions the appearance of having been twice printed.

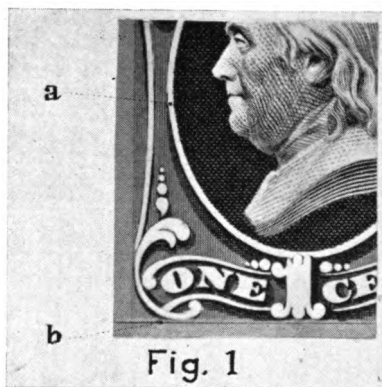

On this die block one of the background horizontal shade lines extending from the middle of the upper lip, has been carried a slight distance into the white ellipse, as indicated at c in Fig. 2, but this defect was removed from the transfer roll, and its absence on any one cent stamp at once identifies it as a printing from a National Bank Note Co.'s plate. On some specimens it is difficult to distinguish this line extension c, owing to blurred or imperfect impressions, or its modification on "shifted transfer" varieties, which are numerous in the Continental and American Co.'s printings.

A number of copies of one cent stamps exist on which the "secret mark" is indistinguishable, but which do show this line extension c, and all those seen are on the paper used by the Continental Co. in 1878 and 1879 or on the soft porous paper of the American Bank Note Co. It is evident that they are printings from worn plates of these Companies. No genuinely grilled one cent stamps of the 1870 issue or any one cent stamps which bear distinctive National Co. characteristics, and which also show this line extension c, have been seen.

This line should not be confused with the "guide dot" which shows on 95% of the National and Continental Co.'s stamps, and generally in the location indicated by a, Fig. 1, and d, Fig. 2. This guide dot is always below the line extending from the mouth of the portrait, and may vary .05 in. to the right or left, from its position shown in Figs. 1 and 2.

Another characteristic of the National Co.'s plates is the position dot and guide line that exists .01 to .02 in. below the design of the bottom row of stamps on each plate; and as indicated at b in Fig. 1. The guide line shows only on early impressions from the plate, as it was but lightly cut and quickly wore away; but the position dot can usually be noticed. Some of the Continental and American plates also show a position dot, f in Fig. 2; but it is oval in shape, further to the left, and generally is cut by the stamp design.

The secret mark placed on this die by the Continental Bank Note Co. has never been correctly described. It consists of irregular crescent shaped scratches on the first two pearls to the left and the first pearl to the right of the numeral "1" as shown at e, Fig. 2. These three marks are clearly shown on die and plate proof impressions and can be distinguished on many of the issued stamps, especially on the re-engraved stamps of 1882, but owing to their being but lightly cut, they do not show plainly, and after the plate has been in use for some time, generally only the mark on the pearl to the left of the numeral shows, but on some copies of the Continental and American Co.'s printing even this mark disappears, and we must rely on other characteristics to properly classify the stamps.

The next alterations to this die were made by the American Bank Note Co. in 1881, and the description of these changes is admirably set forth in Mr. Luff's book "The Postage Stamps of the United States", from which is quoted the following:

"The vertical lines of the background have been much deepened in the upper part of the stamp, so that, in many impressions the background appears to be solid. Lines of shading have been added inside the arabesques in the upper corners. The fine shadings outside the arabesques and at the ends of the upper label have been nearly obliterated by the recutting."

I have it from authoritative sources that it would have been impracticable to make these changes on the hardened dies, and as it was not difficult, although hazardous, to soften the die, and re-harden it after re-engraving, this process undoubtedly was used.

The original die block of the one cent stamp made by the National Bank Note Co., and showing the alterations of the Continental and American Bank Note Companies, is now in the vaults of the Bureau of Engraving and Printing and bears the Index No. P. O. 131 etched on the reverse. There is also in the vault another die of the one cent stamp bearing index No. P. O. 323 which, at first glance, appeared to be a duplicate of the National Co.'s die before any alterations were made, but examination showed slight changes in the frame design and inquiry developed the fact that when the Bureau of Engraving & Printing were ordered by the P. O. Department in 1903 to make die impressions of all the stamps issued by the United States, no die for the one cent 1870 series could be found; therefore one was made by transferring the head of Franklin from one of the Department stamps, and re-engraving the frame design and inscriptions. This latter work was carefully done and is a very clever imitation of the original stamp. This die was never hardened and impressions from it are very scarce, the only known ones being in the bound volumes of die proofs issued by the P. O. Department in 1904, and in the set of die proofs made this year for exhibition at the Panama-Pacific Exposition.

(To be continued.)

THE POSTAL ISSUES OF AUSTRIA.

BY J. BRACE CHITTENDEN, Ph. D.

(Continued.)

Note 1. The general designs for the stamps of this issue were used for fifteen years and are probably as common as any that were ever issued. Notwithstanding, they constitute a most difficult and interesting study, second only to those of the first issue. The 25K. and the 50K. were not issued until Aug. 22, 1867, and are considered by Austrian collectors to be a separate issue. When watermarks, perforations and types are considered, completeness, even for wealthy collectors must be as remote a possibility as British Guiana or Mauritius.

Note 2. Only stamps used prior to 1871 were good for postage in Hungary. The first issue of Hungary occurred May 1st, 1871, but the present issue was not demonetized there until July 31st, 1871. Stamps of both countries therefore may be found together on the same envelope. After 1875 this issue and all that follow it were not used in Hungary (Group 13). It follows only that the coarse beard (Plates 1 and 2) come under the general subdivision A, (Table 17), and that Hungarian cancellations should not occur on the fine beards or on any issue after this date.

Note 3. Paper distinctions are so slight as to cause them to be neglected in the present issue, except in case of the very thin variety which as heretofore is called through shining paper. This is logical in this instance as a

classification according to plates generally preferred, sufficiently distinguishes the several papers employed. At first the paper was rough and coarse grained but later after 1870 smooth. Herr Kropf claims to have seen the 2K. and the 5K. on fine ribbed paper.

Again stamps issued in 1883-4 were on a new paper and carried a new watermark Wmk. 3 Illustration 77, the last watermark used for postage stamps in Austria until 1890. The letters are similar to Wmk. 2 but very thick in comparison. A stamp cancelled 83-84 with a full letter of Wmk. 3 is scarce enough for a page by itself.

BRIEF-MARKEN

WMK. 3.—Illustration 77.

Note 4. All the values were re-engraved in or about 1877 and the 5K. which was used the most, sustained several retouches that are very characteristic. Following the Austrian plan then, and reserving the question of perforations for a later consideration it is practicable to exhibit the primary types in ten or fifteen complete sets with the additions shown in Table 18 to illustrate the 5K. as follows:

TABLE 18.
Coarse beards. Duration. 5K. types (Arabesques). Ears.
(Illustrations 78-88)

- A. Plate I, 1867-70, I a/c, I b/c, E1, E2, E3. "5K." (4mm.)
 - B. Plate I, 1867-70, I a/c, I b/c, E1, E2, E3. Watermarked Wmk. 2.
 - C. Plate II, 1870-80, II b/c, II a/c, E1, E2, E3. "5K." (4.5mm.)
 - D. Plate II, 1870-80, II b/c, II a/c, E1, E2, E3. Watermarked Wmk. 2.
- Fine beards.**
- E. Plate III, 1877-83, II b/c, II b/d, III b/c, III b/d. E1. "5K." (4.5mm.)
 - F. Plate III, 1877-83, II b/c, II b/d, III b/c, III b/d, E1. Watermarked Wmk. 2 or 3.
 - G. Plate IV, 1880-83, II b/e, E1. "5K." (4.5mm.)
 - H. Plate IV, 1880-83, II b/e, E1. Watermarked Wmk. 2 or 3.
 - I. Plate III or IV, P. 9 (8½-10).
 - J. Plate III and IV, p. 10½ (10¼-11).
 - K. Plate III and IV, p. 12.
 - L. Plate III and IV, p. 13.
 - M. Compound perforations of I, J, K and L only, other combinations being considered variations from standard only.
 - N. Through shining paper.
 - O. Rare perforations, watermarked.

In addition to the above exhibit, complete sets of eleven stamps for each value, each stamp showing clearly one of the letters and collectively the completed watermark "BRIEF-MARKEN" may be obtained. With traces of the watermark they are five times as rare as the ordinary variety and with a full or legible letter still more so.

Finally the great rarities in this set, outside of the perforation varieties, are the following: No. 30, 10K. and No. 31, 15K. showing a double strike, Kohl \$15 and No. 33 pair imperf. \$50; also all values come with 1 to 3 outer-lines as follows:

- 2K. 3 parallel lines below.
- 3K. 3 parallel lines below one fine and two thick.
- 3K. One line below.
- 5K. One line below.
- 10K. One line ½ mm. thick, below.
- 15K. One line, thick, below.

Note 5. To explain properly the foregoing plan of an exhibit of this issue we have:

PLATE I. Line engraving coarse, especially the hair and beard. Shading of the eyebrows appears even under a magnifying glass like one thick line. Colors are dim and without gloss. Approximate dates 1867-72 though occasional examples may occur as late as 1874.

PLATE II. Similar to plate I but the shading of the eyebrows is formed of distinct lines and the general tone is lighter showing the worn plate. Approximate date 1870-1880.

PLATE III. Line engraving fine, especially observed in the beard and hair. The coloring is more brilliant and glossy. Approximate date 1877-1883.

PLATE IV. Similar to Plate III but showing only an outline of the head with here and there a line as in a worn plate. Approximate date 1880-83.

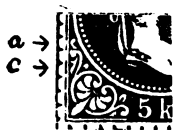

I
ILL. 78



I
ILL. 79



II
ILL. 80



II
ILL. 81.



III
ILL. 82.



III
ILL. 83



III
ILL. 84.

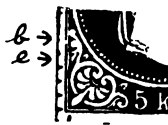

IV
ILL. 85

Types of the 5K. Variations in the scrolls.

PLATE I. Coarse board. 5K. narrow (4mm).

Type I. a/c (Ill. 78) Ornament I does not enter the curve of the ball; stops short of the ball.

Ornament a/ upper scroll stands free of the main design.

Ornament /c, left hand lower scroll stands free from the main design.

Type I. b/c (Ill. 79) Scroll b/ touches the ornament (1870-72); /c as before.

PLATE II. Coarse beard. 5K. wide (4.5mm).

Type II. a/c (Ill. 80) Scroll II enters the center of the ball but does not touch it. Scroll a/ stands free. Very scarce. Date uncertain, 1872-75.

Type II. b/c (Ill. 81). Scroll II as before; Scroll b/ connects with the main ornament; Scroll /c stands free.

PLATE III. Fine beard. 5K. wide (4.5mm).

Type II. b/c (Ill. 82) as before.

Type II. b/d (Ill. 83) both b and d are connected with the main ornament the d connection being very high up. (1875-81).

Type III. b/d (Ill. 84) ornament 3 enters the ball and is distinctly observed to touch it.

Type III. b/c, very scarce.

PLATE IV. Fine beard. 5K. wide (4.5mm).

Type II. b/e (Ill. 85) both b and e are connected with the main ornament as in b/d only the e scroll is more strongly joined and lower down. (1881-83).

Type I. (two subtypes) on coarse beards only, Plate I.

Type II. (4 or 5 subtypes) on coarse and fine beards, Plates II, III.

Type II can be subdivided into 5 instead of 4 subtypes if notice is taken of the lower elliptical ornament.

Type III (no subtypes) on fine beards only.

The establishment of the foregoing plate varieties and comparative dates is due to the remarkable studies of Herr Hauptman E. Conradi, Vienna (I. B. J.) Herr Rechnungsrat Grundel (D. B. Z. 1903) and Herr Kropf, Page 61, 2nd. edition. All the types found in plates III and IV. (fine beards) are likely to occur with any of the perforations.

NOTE 6. A minor classification of little importance may be made, due to a variation in the lines of the ears, as shown in table 18, E1, E2 and E3; E1 is the normal type occurring in all the plates and exclusively in the fine beards (III and IV) and in Plate II of the coarse beards. In the coarse beards Plate I, either I a/c or I b/c, the three varieties E1, E2, E3 may be found, the order of their date of appearance being indicated by the subscripts. (Ills. 86-88).

NOTE 7. Plate I of the 5K. is further distinguished by the width of the "5K." which is narrow (4mm.), whereas in the later plates II, III, IV., they are wide (4.5mm.).

NOTE 8. Watermarks. Every sheet contained 100 stamps and across the middle the watermark "BRIEF-MARKEN," the word BRIEF standing above the word MARKEN, (Wmk. 2, Ill. 74). New paper having been ordered for the next issue, some of it was used in the last deliveries (1883-84). This was similarly watermarked, but with the letters much thicker and in which the vertical lines do not cross the horizontal spaces (Wmk. 3, Ill. 77). This watermark was designed for the issue of 1883-90, the last issue of the Austrian postage stamps on watermarked paper.

On an average, 20 stamps show a trace of the letters in each sheet, making them about 5 times as scarce as the unwatermarked. Stamps with Wmk. 2 and Wmk. 3 are to be sought among stamps having postmarks '83 or '84 (fine beards), and of course are much more valuable. Any stamp showing the entire letter, as sometimes occurs, is especially desirable. They also come inverted. I have complete sets of the 3K. 5K. and 10K. with Wmk. 2 only. A pair of the 10K. inverted and the 2K. with Wmk. 3.

NOTE 9. Perforations. The general question of the Austrian perforations has to be mastered in connection with this issue and its solution stands a monument to the Austrian collectors who have reduced the problem so that they may be classified, although as yet but little is known, at least generally, concerning their comparative rarity. The first machine invented to perforate Austrian stamps was the so-called Line Perforating Machine requiring the horizontal and vertical lines to be perforated separately, and as I understand it, requiring more or less personal guidance, thereby departing frequently from the straight line and producing great irregularities. They were comparatively cheap and introduced as occasion required, especially in the case of the newspaper stamps. With the introduction of the second issue, a machine was perfected to perforate with one process; first a sheet of 64 and later of 100 stamps known as a through boring machine. Stamps so perforated show great irregularity as in the preceding issues except as to centering; three of these machines were in use and sufficed for all postage stamps until the issue of 1877-84. At first they were constructed to show p.15 or 14 ¼ but finally a uniform perforation of 9 ½ (regular). They required the service of one man and two boys to operate and cost 800 fr. The third machine to be installed is the so-called complete perforating machine which was first introduced in 1898 and performs all the work at once on the stamps issued after that date.

In case of the present issue however, only the three through boring machines were on hand and their output 300,000 stamps each, per day was not sufficient, so many additional line perforating machines were used to help out. The teeth of these line machines were not only different but when repaired no care was taken to preserve the same scale and it frequently happened that sheets partly perforated with one machine were finished with another, thus giving rise to the extraordinary number of varieties found in this and the next issue. Again the teeth of the through boring machines wore out from time to time and were replaced by others of a different scale for the stamp in question so that a compound perforation resulted, perhaps the same on three sides and different on the fourth or even different on all four sides. Apparently at first, the through boring machines sufficed, for the coarse beards, Plates I and II are uniformly perforated 9 ½. Again the line perforating machines through constant slight variations are never certain to show

precisely the same perforation, therefore largely through the work of Herr. R. Grundel in Chemnitz, they are to be grouped according as they were or were not perforated by the same machine, the variations thereof being considered as of equal value as follows.

A. Perf. $9\frac{1}{2}$, Regular, equals Rg. (4 regular corners, hor. 9, vert. 11, varying between $9\frac{1}{4}$, $9\frac{3}{4}$).

B. Perf. 9, Irregular line perforations, equals Ir. ($8\frac{1}{2}$, 9, $9\frac{1}{2}$, 10) and their combinations.

C. Perf. $10\frac{1}{2}$ Ir. ($10\frac{1}{4}$, $10\frac{1}{2}$, $10\frac{3}{4}$, 11) and their combinations.

D. Perf. 12 Ir. ($11\frac{3}{4}$, 12, $12\frac{1}{4}$) and combinations.

E. Perf. 13. Appears Rg. ($12\frac{3}{4}$ - $13\frac{1}{2}$).

As a consequence only combinations of these five primary perforations are to be considered as compound. The known varieties are given in the following table. All possible varieties recorded to the $\frac{1}{2}$ perf. were classified through years of work by Herr Ed. Horak and Major Scheneck (78 var. in all). All things considered there is every reason to collect them according to Kohl, who adopts Herr Grundel's results.

TABLE 19.
PERFORATIONS. 1867. (27-33).

| Primary | 2, 3, 5, 10, 15, 25, 50K. | Compound | 2, 3, 5, 10, 15, 25, 50K. |
|----------------------|---------------------------|---------------------|---------------------------|
| $9\frac{1}{2}$ (Reg) | 2, 3, 5, 10, 15, 25, — | | |
| 9 | 2, 3, 5, 10, 15, — | 9:13 | — — 5, — — — — |
| $10\frac{1}{2}$ | 2, 3, 5, 10, 15, — | 9: $10\frac{1}{2}$ | 2, 3, 5, 10, — — — |
| 12 | 2, 3, 5, 10, 15, — 50 | $10\frac{1}{2}$:9 | 2, 3, 5, 10, 15, — — |
| 13 | 2, 3, 5, 10, 15, — 50 | $10\frac{1}{2}$:12 | — 3, 5, — — — — |
| | | 12:10 $\frac{1}{2}$ | — — 5, — — — — |
| | | $10\frac{1}{2}$:13 | 2, — 5, 10, — — — |
| | | 13:10 $\frac{1}{2}$ | — — 5, 10, — — — |
| | | 12:13 | — — 5, — — — — |

A collection according to Kohl is all that is sensible or necessary to illustrate the issue completely, treating all the perforations by the same machine as practically the same, for example Set J. perf. $10\frac{1}{2}$ ($10\frac{1}{4}$, $10\frac{1}{2}$, $10\frac{3}{4}$, 11). For the sake of completeness the following table is given illustrating all the known perforations as prepared after a lifetime of research by Herr Edward Horak and Major Scheneck.

(To be continued.)

NEW ISSUE NOTES.

Through the kindness of Mr. J. B. Leavy, we print herewith a copy of the circular sent out by the Director of the Universal Postal Union, under date of March 6th, 1915, announcing the February distribution. The British Colonials are on paper colored through for such values as come on the colored paper.

A. Egypt: Postage stamps of 1 millieme, 3 and 5 milliemes bearing the surcharge "O. H. H. S.";

B. Ministry of French Colonies. Oceanic Settlements: Postage stamp of 15 centimes;

C. Great Britain. Morocco Agencies: Postage stamps of 15 centimos on $1\frac{1}{2}$ penny, 20 centimos on 2 pence, 25 centimos on $2\frac{1}{2}$ pence, 1 peseta on 10 pence and 2 shillings 6 pence;

East Africa and Uganda: Registered envelope 18 cents;

Barbados: Postal cards of $\frac{1}{2}$ and 1 penny;

Cayman Islands: Postage stamps of 3 pence and 10 shillings;

Ceylon: Postage stamps of 1 and 5 rupies;

Cyprus: Postage stamps of 9, 18 and 45 piastres; postal card of 10 paras;

Falkland Islands: Postage stamp of 5 shillings;

Grenada: Postage stamp of 3 pence;

British Guiana: Postage stamp of 72 cents;

British Honduras: Postage stamps of 1, 2 and 5 cents; stamped envelope of 5 cents;

Jamaica: Postage stamp of 4 pence;

Leeward Islands: Postage stamps of 1 and 5 shillings;

- Malta: Postage stamp of 1 shilling;
 Montserrat: Postage stamp of 3 pence;
 Nigeria: Postal cards of 1 penny and 1 + 1 penny;
 St. Lucia: Postage stamp of 4 pence;
 St. Vincent: Registered envelope of 2 pence and newspaper wrapper of ½ penny;
 Straits Settlements: Postage stamps of 10 cents, 2 and 5 dollars;
 Trengganu: Postage stamps of 2, 4, 5, 10, 25, 30 cents and 3 dollars;
 Trinidad and Tobago: Postage stamps of 4 pence, 1 and 5 shillings and 1 pound; Postal cards of ½ and 1 penny and registered envelope of 2 pence;
 Zanzibar: Postage stamps of 1, 3 and 6 cents;
 D. Nicaragua: Postage stamps of ½, 1, 2, 3, 4, 5, 6, 10, 15, 20, 25, 50 centavos; official stamps of 1, 2, 3, 4, 5, 6, 10, 15, 20, 25, 50 centavos;
 E. New Zealand: Postage stamps of 5 and 10 shillings and 1 pound bearing the surcharged word "SAMOA", and for use in the part of the islands of that name that is under the military occupation of the British Government (these stamps are sent out at the express demand of the Office of New Zealand);
 F. Persia: Postage stamps of 1 chahi on 5 chahis, 2 chahis on 5 chahis and 6 on 12 chahis;
 G. Roumania: Postage stamps of 5, 10 and 50 bani bearing the surcharge in black "Timbru de ajutor" (these stamps are only available for service in the interior of Roumania; the produce of their sale is destined for a fund to succor the families of soldiers in case of mobilization).

JAURENIA—In the list of the Colonial Journal as given out in the October GAZETTE, we find the name Jaurenia in connection with a 4p stamp, printed for the first time on yellow paper. In reply to our inquiry for information, the Crown Agents for the Colonies informed us that the word JAURENIA was a misprint for the word JAMAICA.

NEW PLATE NUMBERS.

Through the courtesy of Mr. J. E. Ralph, Director of the Bureau of Engraving and Printing, we are able to furnish our readers with the full list of plate numbers to April 1, 1915:

| No. | Den. | Class | No. | Den. | Class |
|------|------|--------------|------|------|----------|
| | | | 7306 | 1c | Ordinary |
| 7279 | 1c | Panama Canal | 7307 | 1c | " |
| 7280 | 1c | " | 7308 | 1c | " |
| 7281 | 1c | Ordinary | 7309 | 1c | " |
| 7282 | 1c | " | 7310 | 1c | " |
| 7283 | 1c | " | 7311 | 2c | " |
| 7284 | 1c | " | 7312 | 1c | " |
| 7285 | 1c | " | 7313 | 2c | " |
| 7286 | 1c | Panama Canal | 7314 | 2c | " |
| 7287 | 1c | " | 7315 | 2c | " |
| 7288 | 1c | Ordinary | 7316 | 2c | " |
| 7289 | 1c | " | 7317 | 2c | " |
| 7290 | 1c | " | 7318 | 2c | " |
| 7291 | 1c | " | 7319 | 2c | " |
| 7292 | 1c | " | 7320 | 1c | " |
| 7293 | 1c | " | 7321 | 2c | " |
| 7294 | 1c | " | 7322 | 2c | " |
| 7295 | 1c | " | 7323 | 2c | " |
| 7296 | 1c | " | 7324 | 2c | " |
| 7297 | 1c | " | 7325 | 2c | Book |
| 7298 | 1c | " | 7326 | 1c | Ordinary |
| 7299 | 1c | " | 7327 | 2c | " |
| 7300 | 1c | " | 7328 | 2c | " |
| 7301 | 1c | " | 7329 | 1c | " |
| 7302 | 1c | " | 7330 | 2c | " |
| 7303 | 1c | " | 7331 | 4c | " |
| 7304 | 1c | " | 7332 | 1c | " |
| 7305 | 1c | " | 7333 | 2c | " |

| No. | Den. | Class | No. | Den. | Class |
|------|------|----------|------|------|-------------------|
| 7334 | 2c | Ordinary | 7377 | 2c | Ordinary |
| 7335 | 2c | " | 7378 | 2c | " |
| 7336 | 2c | " | 7379 | 10c | " |
| 7337 | 2c | " | 7380 | 1c | " |
| 7338 | 1c | " | 7381 | 1c | " |
| 7339 | 2c | " | 7382 | 1c | " |
| 7340 | 2c | " | 7383 | 2c | " |
| 7341 | 2c | " | 7384 | 1c | " |
| 7342 | 2c | " | 7385 | 10c | " |
| 7343 | 2c | " | 7386 | 2c | " |
| 7344 | 2c | " | 7387 | 2c | " |
| 7345 | 2c | " | 7388 | 2c | " |
| 7346 | 2c | " | 7389 | 2c | " |
| 7347 | 2c | " | 7390 | 2c | " |
| 7348 | 4c | " | 7391 | 2c | " |
| 7349 | 2c | " | 7392 | 2c | " |
| 7350 | 2c | " | 7393 | 2c | " |
| 7351 | 1c | " | 7394 | 2c | " |
| 7352 | 2c | " | 7395 | 2c | " |
| 7353 | 2c | " | 7396 | 2c | " |
| 7354 | 2c | " | 7397 | 2c | " |
| 7355 | 2c | " | 7398 | 2c | " |
| 7356 | 2c | " | 7399 | 2c | " |
| 7357 | 2c | " | 7400 | 2c | " |
| 7358 | 10c | " | 7401 | 2c | " |
| 7359 | 1c | " | 7402 | 2c | " |
| 7360 | 2c | " | 7403 | 2c | " |
| 7361 | 1c | " | 7404 | 2c | " |
| 7362 | 4c | " | 7405 | 2c | " |
| 7363 | 1c | " | 7406 | 2c | " |
| 7364 | 1c | " | 7407 | 2c | " |
| 7365 | 1c | " | 7408 | 2c | Ordinary (Curved) |
| 7366 | 2c | " | 7409 | 2c | " |
| 7367 | 2c | " | 7410 | 2c | " |
| 7368 | 2c | " | 7411 | 2c | Panama Canal |
| 7369 | 10c | " | 7412 | 2c | " |
| 7370 | 1c | " | 7413 | 2c | " |
| 7371 | 1c | " | 7414 | 2c | Ordinary (Curved) |
| 7372 | 4c | " | 7415 | 2c | " |
| 7373 | 2c | " | 7416 | 2c | " |
| 7374 | 1c | " | 7417 | 2c | " (Curved) |
| 7375 | 1c | " | 7418 | 2c | " |
| 7376 | 2c | " | 7419 | 2c | Panama Canal |

CHRONICLE OF U. S. ENVELOPES.

| B. No. | Denom. | Die Var. | Size | Paper | Wmk. | Kn. |
|--------|--------|----------|------|--------|------|-----|
| 2245A | 1c | C v.2 | 6 | Manila | 15 | 81* |
| 2288 | 1c | A | 8 | Amber | 16 | 59 |
| 2469A | 4c | B | 7 | Amber | 17 | 51 |
| 2491A | 2c | A | 7 | Blue | 18 | 51 |
| 2491B | 2c | A | 7 | O.Buff | 18 | 51 |
| 2614d | 2c | D v.4 | 5 | Amber | 17 | 87 |
| 2614f | 2c | D v.6 | 5 | Amber | 17 | 87 |
| 2614h | 2c | D v.8 | 5 | Amber | 17 | 87 |
| 2614i | 2c | D v.9 | 5 | Amber | 17 | 87 |
| 2614j | 2c | D v.10 | 5 | Amber | 17 | 87 |
| 2614Ab | 2c | D v.2 | 5 | O.Buff | 17 | 87 |
| 2673g | 2c | D v.7 | 5 | White | 18 | 87 |
| 2673h | 2c | D v.8 | 5 | White | 18 | 87 |
| 2673i | 2c | D v.9 | 5 | White | 18 | 87 |
| 2673j | 2c | D v.10 | 5 | White | 18 | 87 |
| 2673k | 2c | D v.11 | 5 | White | 18 | 87 |

* Open end.



Published the 15th day of each month

J. KLEMMANN, Jr., Editor.

CLIFTON A. HOWES, Special Contributing Editor.

JOHN A. KLEMMANN, Managing Editor.

Staff Writers.

CHARLES LATHROP PACK

VICTOR M. BERTHOLD

J. MURRAY BARTELS

DR. CARROLL CHASE

A. E. OWEN

W. B. SPRAGUE

B. W. H. POOLE

SUBSCRIPTION \$1.00 A YEAR, SINGLE NUMBERS 10c.

Advertising Rates on Application.

NASSAU STAMP CO., Publishers, 118 NASSAU ST., NEW YORK.

VOL. V.

NEW YORK, APRIL, 1915.

No. 4.

EDITORIAL.

Prosperity.

This much abused word which has been battered and tossed about by all the parties till each had a different idea to convey by it, seems at last to be coming into its own, and successful progress in business generally seems assured.

Of course there are many contributing factors, a thorough discussion of which would carry us considerably beyond the space we reserve for our opinions so we will confine ourselves to the closest limits.

The American Exchange National Bank in New York canvassed the representative banks in various sections of the country and made the following report of the results to its customers.

"Crop prospects in the Middle Atlantic, Central West, Northwest, Pacific and Southern States are uniformly excellent. The wheat belt looks for bumper harvests. The beet sugar interests are increasing their acreage. The South is cutting down its cotton acreage and turning to grain, fruits and cattle. General business is fair, but markedly hopeful. Money is plentiful and the demand for it light.

In only two lines is there marked depression: Lumber and Jewelry. The former is suffering from overproduction and lack of organization and selling policy and the output of the latter in the New England States is less than 50% that of normal times. On the other hand, automobiles are the best selling articles in the whole length and breadth of the land."

Thus we have a very cheery outlook with regard to the fundamentals which are the source of wealth.

In the stamp trade we find the same conditions of activity. From Chicago, Boston, Philadelphia and Washington come the reports, "Business is good and better than a year ago," while the conditions in New York are such as we have not known them in a long time—one house alone having

sold collections aggregating \$30,000.00 cash during the first half of the month.

The prediction made by our Managing Editor on his return from Europe in the September number of the GAZETTE bids fair to be realized, and after nearly nine months of war no offerings have reached us from Europe, but on the contrary there is a steady stream of buying orders and prices have had to rise.

The A. P. S. Convention.

The time for the Annual Convention of the A. P. S. is drawing nigh and it is not too soon to begin making plans to go as there will be so much more in connection with the Panama-Pacific Exposition that the few days usually allowed for the convention will not be sufficient.

We trust there will be a good representation from the East and will be glad to hear from those members who intend to go.

Our Managing Editor Mr. John A. Klemann is going, and will be glad to represent any of the A. P. S. members in this vicinity who cannot attend.

We would also like to hear from any of the members in regard to matters for discussion at the convention and take this opportunity to state that the columns of the GAZETTE are open to a full discussion of all questions which may be of interest to the members of the Society.

Western Franks.

Many of our readers will be pleased to learn that the J. M. Bartels Co. have just published 12 finely illustrated plates of the early Western Franks of the U. S. together with a numbered list of the 178 different express companies known to have been engaged in the mail service.

These Franks mark an important epoch in the history of the civilization and commercial advancement of the West and tell much of that unique mail service which played such a vital part in the development of that section of the Nation.

Many of these letters were carried by the intrepid riders across almost unsurmountable barriers of nature and through vast areas inhabited only by wild Indian tribes, ever ready to intercept the daring horseman to whom was entrusted the transportation of the mail.

There is considerable activity in the Philatelic publishing line and the absorption of the Stamp Journal, The Philadelphia Stamp News and the New England Philatelist by the publishers of the Collectors Blue Book is a good and healthy sign.

We shall be much interested to watch the progress of the Blue Book and wish it all success.

We can still use one or two more pages of advertising matter and make this appeal to really first-class dealers who desire space in a high class publication.

Our rates are no higher than any other publication considering the class of readers we reach.

We print below, a schedule of rates on time contract and solicit correspondence.

| | 1 mo. | 3 mos. | 6 mos. | 9 mos. | 12 mos. |
|------------------|--------|--------|--------|---------|---------|
| 1 inch | \$1.50 | \$4.00 | \$7.75 | \$11.50 | \$15.00 |
| ¼ p. | 5.00 | 13.50 | 26.25 | 38.00 | 50.00 |
| ½ p. | 8.50 | 23.00 | 44.50 | 65.00 | 85.00 |
| 1 page | 15.00 | 40.50 | 78.75 | 114.75 | 150.00 |

UNITED STATES LOCAL STAMPS.

A Concise History and Memoranda

COMPILED BY HENRY C. NEEDHAM.

PREFACE.

For thirty years and upwards the writer has been a collector of stamps; he has seen the supply of early issues of all countries gradually disappear, and the prices, naturally, soar. During his early experience he often wondered at the extreme scarcity of the stamps issued by the proprietors of the Local Posts and the Independent Mail Routes. He finally came to realize that these stamps—the forerunners of all Government issues—were of much more philatelic and historic interest than all others; they were issued by the men who thought out and perfected the rules, regulations, appurtenances and conveniences later taken and assumed by the different Governments in the management of the various Post Office Departments; their ideas were followed. Their profits were fully realized by the heads of the Government, and, for many years, the legal force of the Post Office Department of the United States was bent on crushing the industry created by these men. It is, today, often impossible to settle definitely the date of issue of certain of these stamps, and we do not yet know full particulars of many Posts. We are still occasionally surprised to find an emission of some entirely different type, or on a paper entirely different from the generally accepted emission of a Post. The place of issue of certain recognized Posts is also occasionally uncertain or absolutely unknown.

It is hoped that the publication of the various articles, to follow that in the present number of THE PHILATELIC GAZETTE, will so appeal to collectors, dealers, and old time residents, and, perhaps, to employees of ancient Posts, that much additional data will be procured. We appeal to all persons having knowledge of facts, figures or history, other than as published, to communicate with the author of this article, or the proprietors of THE GAZETTE.

The writer has compiled his data, not only from original investigation, and, we may say, elimination, but from the earlier work and discoveries of John W. Scott, E. Harrison Sanford, F. W. Hunter, Charles T. Harbeck, and that monumental work compiled by the late Charles H. Coster; to all of whom due credit is given.

ADAMS & COMPANY.

This Company operated solely and entirely on the Pacific Slope. While affiliated with the express business of Adams & Company, of the Atlantic Coast, it was entirely separate and distinct as to management and capital, but, at all times up to the time of incorporation, was a branch of the parent company. Alvin Adams, proprietor of the Eastern Company, was a special partner in the original business of Adams & Company of the Pacific.

Alvin Adams was born at Andover, Vermont, June 6th, 1804. In early life he located at Boston, Mass., and engaged in the produce business at wholesale and commission. He is often referred to as "the Boston Grocer". In his business he found great difficulty in procuring his supplies from the farms and factories. This created in his mind the idea of establishing an express company for the prompt delivery of produce and all other matter; the idea of conducting a business for the delivery of letters came later.

William F. Harnden, who originally created the express business, in America about 1839, was located at Boston and a friend of Adams. Harnden had been a conductor on the Boston and Worcester Railroad, later a part of the Boston & Albany Line. His small express business was conducted from No. 9 Court Street, Boston, and 1 Wall Street, New York; it was not successful during the lifetime of Harnden, but later developed materially. Adams became Harnden's first competitor, and two years after Harnden's death, 1852, he purchased the assets of the Harnden Express Company and joined it with the Adams Express Company of the Atlantic. The name of Harnden's Express, however, was retained. In 1857 its office was at 74 Broadway, and its business, in certain territory had been transferred to Thompson, Livingston & Co. We might call attention to the fact that Harnden's partner was Henry Wells, and that William C. Fargo, an ex-Railroad man, was later Wells' agent at Buffalo, Wells about 1843 having established a line from Albany to Buffalo and thence to Detroit and the lake ports.

Adams & Company, of the Atlantic, having established a large and prosperous business prior to 1849, realized the great rush which would necessarily follow the discovery of gold in California, and that the express from the east to the west, and from the camps there to other camps and mines, would be in sufficient volume to warrant an investment in the Western Territory, decided to enter that field, but not with the capital of the Eastern Company. They, therefore, set aside a certain sum for the development of the business in the west, and, in the summer of 1849, sent D. H. Haskell of Boston, as resident manager, to the Pacific Coast. He arrived at San Francisco on October 31st, 1849, and, within six weeks, had the business established throughout the State of California and vicinity. Within three months it had a majority of the business in and out of California and the gold fields. A banking department was soon established and added to the business of the company. This banking department was suggested and advised by the merchants in the west, and, we may say, was the cause of all the troubles which ultimately came upon the Company. Haskell at once established routes to Sacramento and Stockton; at the former point the Company connected with the Express of Freeman & Company, which ran to the Northern Mines, and, at the latter point, with Newell & Company which had routes to the Southern Mines. These two connecting concerns were consolidated with Adams & Company about 1854 at the time of the incorporation of Adams & Company as a joint stock concern.

At the opening of the year 1853, Adams & Company held a position of supreme importance throughout the Pacific Territory; they did more business, were in touch with more people, delivered more express and mail matter than did the Government or any other individual concern or corporation. Their bank was the first and largest in the field, and their credit unsurpassed; every agency established by them forced the price of gold dust to a higher level by the increased facilities offered. The merchants, miners and adventurers sent money and letters by the Company to their homes and friends in the Eastern States, and obtained through the Company all letters and express matter forwarded from the east. The business was formed into a joint stock company in May, 1854. The management was vested in D. H. Haskell and I. C. Woods. Its capital was two millions of dollars, and the express business alone amounted to between fifty and sixty thousand dollars per month. The profits from its banking and postal business were very heavy.

Early in 1855 a financial and commercial crisis occurred at San Francisco and throughout the west; there was a run upon the bank of Adams & Company, and the concern was forced to close its doors about October 25th, 1855. Receivers were appointed, more particularly to conserve the two millions of dollars deposited in the banking department of the Company. Much litigation resulted. The Legal Department of the State of California was not then fully developed, and the orders of the Receivers were often not recognized by the officers or officials. There was also trouble with mobs, and much difficulty was experienced in conserving the assets. The litigation was continued for about seven years with the result that lawyers were happy, and the depositors were paid nothing.

(To be continued.)

AUCTION REPORT.

J. C. Morgenthau & Co.—93rd Sale.

| | | |
|---------|--|---------|
| Lot No. | | |
| 324 | U. S. 1873 Continental, 2c brown, double paper (157b), unused, o. g. | \$16.00 |
| 331 | — — 24c deep purple (164), unused | 22.00 |
| 423 | Baden, 1851, 1kr buff (1), horizontal pair, used | 7.50 |
| 449 | Canada, 1859, 2c rose, imperf. (18a), block of 4, unused | 24.10 |
| 467 | Cape of Good Hope, 1855, white paper, 1p dull red (3a), block of 4, used | 12.00 |
| 507 | Puerto Principe, 3c on 2m orange brown, the rare type, (179F), used | 210.00 |
| 514 | — 5c on 1m inverted surcharge (182a), on piece of original | 110.00 |
| 516 | — 5c on 2m, rare type (185), on piece of original | 97.00 |
| 517 | — 5c on 3m (186), with marginal strip at right surcharged, on piece of original | 36.00 |
| 518 | — 5c on 3m, rare type (187), on piece of original | 63.00 |
| 520 | — 5c on 5m, inverted (188a), unused | 93.00 |
| 521 | — 5c on 5m, inverted (188a), on piece of original | 31.00 |
| 522 | — 5c on 5m, rare type, (189), on piece of original | 24.50 |
| 523 | — 5c on 5m, inverted surcharge, horizontal pair, both types, (188a, 189a), on piece of original | 92.00 |
| 531 | — 3c on 1m, orange brown (179A), unused | 41.00 |
| 538 | — 3c on 1c, inverted (196a), on piece of original | 31.00 |
| 541 | — 3c on 1c, (196), horizontal strip of 5, the second stamp the rare type (197), unused, o. g. | 52.00 |
| 543 | — 5c on 1c, inverted (198a), on piece of original | 24.50 |
| 544 | — 5c on 1c, double surcharge (198c), unused, o. g. | 112.00 |
| 551 | — 3c on 1m, inverted (201a), on piece of original | 52.00 |
| 556 | — 3c on 3m (205), unused, o. g. | 100.00 |
| 557 | — 3c on 3m, rare type (206), on piece of original | 62.00 |
| 558 | — 3c on 3m, rare type inverted surcharge (206a), on piece of original | 156.00 |
| 559 | — 5c on 1m blue green (211), on piece of original | 140.00 |
| 560 | — 5c on 1m, rare type (212), on piece of original | 210.00 |
| 561 | — 5c on 2m blue green (213), unused, o. g. | 180.00 |
| 562 | — 5c on 2m blue green, rare type (214), on piece of original | 197.00 |
| 563 | — 5c on 3m blue green (216), on piece of original | 200.00 |
| 564 | — 5c on 4m blue green, error "eents" (217a), on piece of orig- inal | 175.00 |
| 565 | — 5c on 4m blue green, inverted surcharge (217b), on piece of original | 193.00 |
| 566 | — 5c on 8m blue green (219), on piece of original | 51.00 |
| 567 | — 5c on 8m blue green, inverted surcharge (219a), on piece of original | 151.00 |
| 568 | — 5c on 8m, rare type (220), used | 160.00 |
| 569 | — 5c on 8m blue green, rare type, inverted surcharge (220a), on piece of original | 220.00 |
| 710 | Norway, 1854, 4s blue (1), horizontal strip of 4, used | 16.50 |
| 813 | Tobago, 1879, £1 violet (6), unused, o. g. | 25.00 |
| 879 | U. S. 1861 August, 24c violet (60), on cover | 28.00 |
| 888 | — State, 2c dark green, (557), on cover | 6.50 |
| 918 | Confederate States, 1863, 2c brown red (207), horizontal strip of 5 on cover | 9.50 |
| 937 | Bavaria, 1862, 18kr (14), 10 copies used with 2 copies of the 12kr green (13), on cover | 36.00 |
| 959 | France, 1853, 1fr (21), horizontal strip of 6, with pair, 1852 25c blue (11), on cover | 21.00 |
| 973 | Hanover, 1853, 3p rose (7), vertical pair, on cover | 15.50 |
| 978 | Italy, Sardinia Letter Sheets 1819, 15c blue (Senf 1), used | 12.50 |
| 979 | — 15c blue (Senf 1), cancelled in red | 12.50 |
| 980 | — 50c blue (S3), used | 12.50 |
| 992 | New South Wales, 1851, 2p ult., 6p brown (11a, 15), used, on 1 cover | 18.25 |

SOCIETY NOTES.

Garfield Perry Stamp Club.

On March 19th and 20th The Garfield-Perry Stamp Club of Cleveland, Ohio, celebrated its 25th Anniversary and Silver Jubilee. This Club was organized on March 17th, 1890, and has enjoyed 25 years of continuous unbroken activity. Its regular meetings have been held without a single interruption, its membership constantly increasing, until it is today one of the oldest and largest clubs in this country. The entire program for the celebration was carried out at the Colonial Hotel, which was also the headquarters of the out-of-town guests.

March 19.—On Friday afternoon open house was held, and in the evening in the Assembly Room a short meeting of the Club, followed by an Auction Sale of 60 fine lots prepared by Mr. L. A. Hanford, who in turn, turned the sale over to Mr. Henry A. Fowler, of Chicago, who proved to be most able auctioneer. Following the Auction, Dr. Carroll Chase, of Brooklyn, N. Y. exhibited his very fine work of the 1847, 1851-1856-7, and 1861 issues.

March 20.—Saturday afternoon the following Gentlemen exhibited—Mr. Charles Lathrop Pack, 3 Oriel Albums; Argentine 1888; Victoria and Uruguay; and his Gold Medal collection of Queensland. Mr. George H. Worthington, Mauritius; Dr. Carroll Chase, 1847, 1851-6, and 61 issues; Mr. W. H. Schneider, Odities; there were also other collections of local collectors.

March 20—Saturday evening. The 25th Anniversary Banquet was held; attended by 55 members and guests. Mr. John F. Rust, presided as Toastmaster and called upon Messrs. Worthington, Coolidge, Chase, Schneider, Severn, Fowler and Fernald. Out-of-town guests in attendance were Dr. Carroll Chase of Brooklyn, Gen. C. A. Coolidge, Messrs. Fernald, Heyerman of Detroit, Severn, Fowler, Jacobs of Chicago, Stevenson of Flint, Mich., Fischer of Cincinnati, Hoffstetter of Erie, Pa., Deas of Syracuse, Webb of Perry, Ohio, Linn of Columbus, and Stewart of Toledo. The Banquet was most fittingly closed by Mr. L. A. Hanford, who presented the Club with a very fine silver cup in honor of the Clubs Silver Anniversary.

JOHN F. RUST, President.

Pacific Philatelic Society, Branch No. 3.

On Wednesday evening March 17, held their regular 309th meeting at the club rooms of the Society at Oscar Luning Building, No. 45 Kearny St., San Francisco.

Present:—President, Phillips; Vice-President, F. Marcus; Secretary, Marcus; Messrs. Doscher, Smith, Folte, Lazarus, Whischman, H. Seebohm, Steinmann, Dr. Holt, Ruellan.

Visitors:—Mr. H. J. Brackett; C. H. Johnson, A. P. S. 4442; Mr. Chandler, Sec. of the Berkeley Society; Mr. J. B. Fustman.

Minutes of the 308th meeting, approved as read.

Report of the Committee for auditing books of the Secretary approved as read, and committee discharged with thanks.

Reports of the committee on programs and badges approved as read.

The name of Mr. Johnson was presented to the committee on membership to be voted on as a member at the next regular meeting.

Mr. J. H. Brackett being recommended by the committee on members, was duly elected on ballot.

Mr. F. Marcus and Mr. Doscher appointed a committee to call on the lately bereaved family of Mr. Newberry, an A. P. S. and Pacific Philatelic Society member who passed away on March 16 and the Secretary was authorized to send flowers and proper letters of condolence in behalf of the Society.

The first of the general exhibitions of stamps by countries was then held, Russia and Finland being the subject for the night. The committee on exhibits reported as follows:

Marcus Brothers, First Prize; Mr. Folte, Second Prize, Mr. Phillips, Honorable mention.

Among the rarities shown were the inverted net work of Russia, the imperforate rarities, the issues of Wenden complete, and a complete collection of Finland used and unused, with a study of the post marks on the early issues.

Mr. Ruellan who has just returned from France, gave a very interesting talk on conditions in that Republic.

Mr. Steinmann who has just returned from Germany, and more particularly the Austrian frontier, gave us an interesting talk on the scenes enacted in some of the larger campaigns in that district.

Next meeting April 21. Subject, Stamps of Great Britain.

HENRY C. MARCUS, Sec.-Treas.

New York Stamp Society.

Tuxedo Hall, Madison Ave. & 59th Street, New York City, 249th Meeting, April 1, 1915.

Meeting called to order by President Klein at 8:40 P. M. Minutes of our previous meeting were then read and adopted.

Messrs. Chas. Murley and Henry A. Moye were elected to membership.

A letter of thanks was received from Mrs. Julius Levy for the Society's "kind resolutions of sympathy."

Mr. E. L. Weiss, President of the National Philatelic Society, was present. He told us of his Society and also invited the members of ours to attend the Convention which will be held July 23 to 25, 1915.

Our monthly exhibit was won by Mr. Edward J. Koller, with Henry Meininger a very close second. The competition between these two gentlemen being so keen that the Judges, Messrs. Angell, Wolfrum and Falisse, had to exercise their keenest philatelic judgment to decide who had the better collection on exhibition.

We are indebted to Mr. Joseph B. Leavy, Philatelist to the Government, who gave us a good talk about the collection he has charge of at Washington, D. C. He extended an invitation to all of us to come and see what is being done, whenever any of us are in Washington. Mr. Leavy also showed us his Gold Medal Collection of Belgium which was a treat. We regret that Mr. Edgar L. Green was unable to attend and show us his Finland collection in person, but Mr. Klein did the best he could.

The members voted Mr. Leavy and Mr. Green many thanks for their kindness in showing us their splendid collections and hoped that they would come again at some future meeting.

Meeting adjourned at 10:30 P. M.

Guests and Visitors present: Mrs. R. Rodgers, Miss R. A. Rodgers, and Messrs. Joseph B. Leavy, Frederick F. Falisse, E. L. Weiss, Charles Goetz, Ernest Jodicke, A. Bohme, A. Bardnak and L. Martin.

Members present: Mrs. H. Held, and Messrs. E. Angell, J. Murray Bartels, A. Beck, M. O. Brooks, Chas. Jancovich, Eugene Klein, Ed. J. Koller, Chas. Lehman, S. Singer, T. Steinway, B. Wolfrum, H. M. Lewy, H. J. Meininger, Vahan Mozian, J. Monhib, W. O. Staeb, R. Kohler, A. Schiessel, H. F. Raess, B. Schlesinger, G. Solomon, P. Stypman, and A. J. Wagner.

We meet every 1st and 3rd Thursday and extend a cordial invitation to all who are interested in stamps to attend any of our meetings.

G. DENZAU, Secretary.

Washington State Philatelic Society, Inc.

Headquarters, 4095 Arcade Building, Seattle, Washington. Meetings 8 p. m. every Tuesday, 206 Walker Building, Seattle, Wash.

The Washington State Philatelic Society was organized and incorporated under the laws of the State of Washington during the summer of 1912, and has experienced a phenomenal growth and is now one of the strongest Societies in the United States. The increase in the Society during the past year has been exceptional; on Jan. 1, 1914, there were 73 members, and on Jan. 1, 1915, 138 members in good standing, a net increase of 89% during the year.

Under the Constitution and By-Laws of the Society a branch may be formed in any city where there are five or more members, who hold regular meetings; to those branches 50% of the annual dues are remitted by the Society which money is to be used for the expenses of the local branch as the members of that branch may desire. At this time branches of the Society are located at Tacoma, Olympia, and Spokane.

The membership is divided into two classes, active and junior. An active member must be over 18 years of age and pays a membership fee of one dollar, for one share of stock in the Society. All money received from the sale of stock is placed in a trust Fund at interest, the principal not to be used for any purpose. The dues are \$1.00 per annum for active members and 50c per

annum for junior members. A junior member is not required to pay the membership fee \$1.00, but his application card must be signed by some responsible person who guarantees his accounts with the Society. All applicants for active membership are required to give a commercial reference, which is always investigated, with the result that a W. S. P. S. membership number is all that is necessary as a reference with any of the stamp dealers in the World.

The Sales Department of the Society is the second largest in net value of books in circulation of any Society in the United States, having during 1914, a net value of \$5547.37 in circulation. During the past year 278 books were retired, net value \$1990.62, amount sold \$591.73, or sales on books retired averaging 30%. Total sales for the Department during 1914 were over \$1100. Uniform books to hold 100 stamps are furnished by the Society, upon application to the Secretary, at 2½c each; 1% of the net value of the book is deducted for the Insurance Fund, from which any losses are paid; and 10% of the net sales is deducted as commission by the Society.

An Auction is held each month, all stamps being sold by members of the Society, lots to catalog at least \$1.00, the member having the privilege of placing a reserve value on his lots. Anyone can bid at these auctions, subject to the usual auction terms. 10% of the amount realized is deducted by the Society as commission. During 1914 stamps were sold to a total value of \$481.36, sellers realizing over 33% of catalog value, which is a very high average for Auctions.

If you are interested in Philately, why not join a live, up to date, well financed Society, which is on a sound basis, and here to stay. Write for further information as to joining or forming a branch, and get the benefit of our Auctions and Sales Departments.

C. R. CALLAHAN, Secretary.

Collectors Club.

30 East 42d Street, New York City.

The regular monthly meeting will be held in the club rooms on Wednesday evening April 28th at 8 o'clock P. M.

The German Colonial Issues are scheduled for competition in accordance with the plan outlined in the February GAZETTE.

Last month there were seven entries and the members who attended the meeting had a very enjoyable time and saw some remarkably fine collections.

The competitions are open to all, whether members or non-members, and awards are made in accordance with the plan mentioned above.

COMMUNICATIONS.

Editor Philatelic Gazette:—

I wish to call to your attention the following methods used by a party calling himself Carl W. Nolan and at the time as will be noted was at Cicero, Indiana. On Feb. 18, 1915 I received a letter from this man requesting a selection of stamps. He gave for reference, four names, mentioned below. I was foolish enough to send this man a selection valued at \$20.00 catalogue. I admit I should have written the party referred to, but that is all over now. You will see that there were others beside myself who were just as easy and careless. Have heard nothing from him since. On March 17th I sent a letter of inquiry. Still no reply and on March 23rd sent return letters to all his references and also the Postmaster at Cicero, Ind. All the letters of reference were returned marked "no such person" or "company" and I herewith quote verbatim the Postmasters reply.

C. J. Moore,

Cicero, Ind., March 27, 1915.

Dear Sir:—

In regard to Carl W. Nolan, I do not know the party. About Feb. 15th, 1915, mail began to arrive at this office for the above party and on the same day I received a card from Mr. Nolan with orders to hold his mail for a week or two and he would call for same. On or about March 1st he called at this office and I delivered his mail to him, which was quite a good bunch, leaving orders to hold his mail until he returned which would be in a little over a week. Up to date I have not seen Mr. Nolan, not since the one time he called here. He made the statement that he was traveling with a show and selling goods by day for extra money. He claimed the show was dated for this place but cancelled the date. I frankly give you the above information which is all I know about Carl W. Nolan. He must have gotten the stamps when he called here for his mail, as there is no mail from you here at present.

(on separate sheet, evidently written later)

I received four letters this morning mail which were mailed by you to the following addresses.

A. G. Rowe, Grocer; Citizens Loan Ass'n.; James Coal Co.; J. B. Lewis, Jeweler. The above are unknown at this office. I suppose the above names are the parties referred to as references. If they are, they are unknown in this locality. If I get a line on Mr. Nolan, I will inform you at once.

Respectfully yours,

C. F. BARDONNER, Postmaster, Cicero, Ind.

From the methods this Nolan uses it is evident that he is an old hand at stamp cheating and while I appreciate my own neglect and that the stamps are gone, I am endeavoring to spare others a similar loss. Can not you help me in putting a stop to his nefarious business. It is only by printing this mans methods, the name Nolan does not matter, it could be Smith just as well. Do your part and inform your readers how they may be cheated unless they write to the references. The letters I have on hand and I will guarantee you against comeback from this fellow, I have written Washington and see what they can do to stop him using the U. S. Mail to defraud. Do your part for the sake of your readers and the stamp fraternity, help weed out these miserable parasites. You may use my name, if necessary, I will gladly furnish the letters if needed. I obtained your name thru the courtesy of *Mekeel's Weekly Stamp News*. Thanking you in advance in a mutual endeavor to help others, I am,

Very truly yours, CHESTER MOORE.

REVIEW.

Postage Stamps of War:

Another line of specialism has been suggested by the title of this booklet which when properly worked out will also have a decided historic value.

Commencing with the Crimean War, which is probably the earliest usage the author takes in all issues associated with the many wars which followed, not confining himself however, to the stamps actually used during those troublous times, but also to such issues as appeared immediately before or after and having any bearing on the war whatever.

Of course the stamps of the present war, the red cross, expeditionary and occupation issues are well treated together with the naval and military postmarks which make a large and interesting group.

Well printed and copiously illustrated it is a book which should be in the hands of all who are interested in just a little more than the actual possession of the stamps.

Postage Stamps of War: ("Stamp Collecting" Handbook No. 2) paper bound, by Douglas B. Armstrong. Published by The Holloway Press Co., 449 Holloway Road, N. London, England. Price 4½p net.

The Postage Stamp in War.

It would not be a timely topic in relation to stamps without a contribution from the ever ready pen of Mr. Melville.

This handbook, for it is gotten out uniform with all the Melville handbooks, is fully up to the standard and what may be expected from the author.

The subject matter is carefully and entertainingly written and covers the subject thoroughly, so thoroughly in fact that the author has included many issues which have only a very remote and indirect connection with war.

Well printed and profusely illustrated, it is a worthy addition to the library of Melville books and should be in the possession of all those who would know the historical reasons for the war issues of stamps.

The Postage Stamp in War, by Fred J. Melville, published by the author, 14 Sudbourne Road, Brixton, London, S. W., England. Price 1sh. net.

Egypt.

With the actual annexation of Egypt to the British Empire the collectors of British Colonials find one more interesting country to collect.

Mr. Melville treats the subject in his usual thorough style and those who know the Melville handbooks, know how thorough that is.

The printing and illustrations are uniform with the others of the handbook series.

Egypt. (Melville Handbook No. 20) by Fred J. Melville. Published by Stanley Gibbons Ltd., 391 Strand, London, W. C., England. Price 6p net.

WHEN REMOUNTING

Your Collection, especially when working on your

FAVORITE COUNTRIES

be sure to send for our carefully compiled

SPECIALIZED SELECTIONS

Some 300 booklets each containing 175-300 choice stamps, the very pick of our large stock; include **pairs, blocks, shades, oddities and varieties** of all kinds, in fact anything likely to interest a specialist or general collector. The early issues are the strongest in these selections. Prices are moderate.

Our **Pink List** gives more detailed information regarding each selection.

J . M . B A R T E L S C O .
99 Nassau Street, New York.

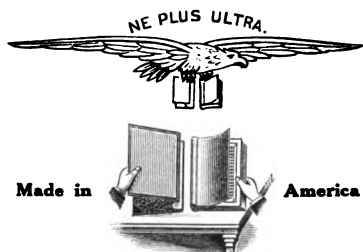

Interchangeable Leaves

BLANK ALBUMS - \$4.00 and up

STOCK BOOKS - \$2.00 and up

Used by the foremost Collectors and Dealers
 Complete price list free on request



"No Plus Ultra" Watermark Revealer
 Price 50c. Postage 10c. extra

All "No Plus Ultra" supplies manufactured exclusively by
SCOTT STAMP & COIN CO.
 127 Madison Ave. New York City

BOUND VOLUMES

of

The Philatelic Gazette

will soon be ready.

| | |
|----------------|------------|
| Vol. I | \$3.00 net |
| Vol. II | 2.50 " |
| Vol. III | 2.50 " |
| Vol. IV | 2.00 " |

118 Nassau St., New York, N.Y.

Locals and Carriers

What have you to offer?

Send at your lowest cash price.

JOHN A. KLEMANN
 118 Nassau St. New York

JUNE SALES

We have made contract to sell at auction during June a
**MAGNIFICENT COLLECTION OF THE STAMPS OF
 EUROPE**

and Colonies of European countries except Great Britain. This Collection is mounted in 23 Oriel Albums and is beyond a question the finest Collection offered for sale this season. It contains both unused and used stamps and aside from the rarities is noteworthy for the remarkable condition of even the common varieties.

German States and Colonies
Italy and Old Italian States
Portugal and Colonies
Spain and Colonies
Sweden
Switzerland—Cantonals
Austria—Lombardy—Hungary
Roumania—Russia—Turkey
France and Colonies

Are especially noteworthy.—In addition to Europe it contains fine specialized collections of

Dominican Republic—Hayti—Egypt
Liberia and Samoa.

This important sale will probably take up 8 or 10 sessions and the Catalogue will be issued in parts and sent **FREE** upon request.

J. C. MORGENTHAU & CO.
87 Nassau St. New York City

THE PHILATELIC GAZETTE

PUBLISHED MONTHLY FOR STAMP COLLECTORS

VOL. V.

NEW YORK, MAY, 1915.

No. 5.

The United States Government Collection of Postage Stamps.

BY JOSEPH B. LEAVY,

Philatelist, U. S. National Museum.

(Continued.)

- — 4c carmine lake
- — 6c purple
- — 8c brown
- — 10c light blue
- — 12c orange
- — 16c olive
- — 20c yellow
- — 26c blue green
- — 30c ultramarine, pale ultramarine
- — 1 peso pale violet
- — 2 pesos violet brown
- — 4 pesos deep blue
- — 10 pesos deep green
- Special Delivery, 1901, 10c dark blue, deep blue
- — 10c indigo, special printing
- 1904, Special printing, 10c ultramarine
- 1906, wmkd. double line P I P S, 10c pale ultramarine, deep ultramarine
- 1911, wmkd. single line P I P S, 10c deep ultramarine
- Postage Due, 1899, 1, 2, 5, 10, 50c deep claret
- — 1, 2, 5, 10, 50c deep claret, handstamped Specimen in small type
- 1901-02, 3, 30c deep claret
- — Special printing, complete set, 1c to 50c
- Officially Sealed, brown orange, perforated 12, no wmk.
- Yellow, yellow olive, rouletted, wmkd. double line P I P S

STAMPED ENVELOPES

- 1903, 1c green and white, amber, oriental buff, blue and manila
- 2c carmine on white, amber, oriental buff and manila
- 1904, recut dies, 2c carmine on white, varieties 32 and 101
- 1908, 2c green on white, amber, oriental buff, blue and manila
- 4c carmine on white, amber, oriental buff, blue and manila
- Die proofs on India paper, 1906, set complete, 2c to 10 pesos, including Special Delivery

CANAL ZONE

- JUNE 1904, handstamped CANAL ZONE on stamps of Panama, Panama reading up, 2c Panama 13 mm long. 2c Panama 15 mm long
- Panama reading down, 2c Panama 13 mm long
- Panama reading up and down, 5c, 10c
- CANAL ZONE inverted, 5c, 10c
- JULY 1904, CANAL ZONE printed on U. S. 1902
- 1c, 2c, 5c, 8c, 10c
- DECEMBER 1904, CANAL ZONE, printed on stamps of Panama
- 1c and 2c normal and A L spaced in pairs
- 1c Zone antique
- 1c Canal antique
- 2c Canal Zone, inverted

- 5c first printing
Normal, A L spaced,
Canal Zone double,
Anama and Panam in a pair.
- MAY 1905, 5c second printing, normal
- AUGUST 1905, 5c third printing, rose
carmine overprint, normal,
inverted M and Panama 16 mm
long in a pair
- SEPTEMBER 1905, 5c third printing,
dull vermilion overprint, nor-
mal, inverted M
- NOVEMBER 1905, 5c fourth print-
ing,
Normal, Zone antique, Pamana,
Panama with middle A miss-
ing.
- MARCH 1906, 5c fifth printing, nor-
mal, Zone antique, Canal an-
tique.
- AUGUST 1906, 5c, sixth printing
Normal, Canal antique, Zone an-
tique, normal and Pamana in
a pair.
- DECEMBER 1904, 8c first printing,
type I, normal;
— — — Type II normal and A L
spaced in pair
— — — Types I and II inverted
in a pair
— — — Small Panama reading
up types I and II
— — — Type II Panama 15
mm long
- SEPTEMBER 1905, 8c, second print-
ing, types I and II
— — — Type II 8 cts double
- NOVEMBER 1905, 8c third printing,
normal and antique Zone in
pair
- APRIL 1906, 8c fourth printing, bar
at bottom
- DECEMBER 1904, 10c first printing,
normal and A L spaced in pair
- NOVEMBER 1905, 10c second print-
ing, normal
- MARCH 1906, 10c third printing, or-
ange-red overprint, inverted
M, Pamana, Panama double,
normal and antique Zone in a
pair
— — — Carmine overprint,
normal
- JUNE 1906, 10c fourth printing,
normal, Canal antique, Zone
antique
- NOVEMBER 1905, period after 8
cents, bar at bottom,
— — — Panama reading up and
down
— — — Normal, antique Zone and
Panama 15mm long in block
of 4
- APRIL 1906, no period after 8 cents,
Canal antique
— — — Panama reading up, and
- Parama reading up and down
in a pair
— — — Normal, antique Zone and
Panama 15mm long in a pair
- JANUARY 1906, 2c dull vermilion
overprint, normal, antique
Zone, inverted M, Panama in-
verted.
— — — 2c, dark carmine overprint,
antique Zone
— — — Normal, inverted M and
Panama 16mm long in block
of 4
- APRIL 1906, 1c, 2c
- MAY 1906, 1c, 2c
- SEPTEMBER 1906, 1c normal and
C A spaced in a pair, 2c
— — — 8c normal, 3mm between 8
and cts and Pamana in block
of 4
— — — Normal and Canal antique
in a pair
— — — Zone antique
— — — 8 cts omitted
- 1906-07 thick soft paper, overprint
reading down
— 1c, 2c, 5c, 8c
— 10c normal and C A spaced in a
pair
— 8c imperforate between vertical-
ly, pair
— 1c imperforate between vertical-
— 1c double surcharge
ly, pair
— 1c double surcharge, one inverted
— overprint reading up 2c
- 1907-08 thinner, hard paper, over-
print reading down
— 1c, green and black, yellow green
and black
— 2c, carmine and black, dull lake
and black
— 5c, dull blue and black, pale blue
and black, dark blue and black
— C A spaced, 1c, 2c, 5c
— Double surcharge, 1c, 2c, 5c
— 1c, "one" for "Zone" in block of
four with normal
— 1c, "ana" for "Canal" in block of
four with normal
— 2c imperforate between vertical-
ly, pair
- 1909 Local overprint, 2, 5, 8, 10c,
normal and C A spaced in
pairs
- 1909-10. 1, 2, 5, 8, 10c
— 2c imperforate between
— 5c double overprint
1911. 10c on 13c
— 10c on 13c, 10c inverted
— 13c 10c omitted
1914. 10c
- 1915, 1c, 2c, 5c, 10c
- 1914 Postage Due, U. S. postage due,
overprinted CANAL ZONE 1c,
2c, 10c

(To be continued.)

BOLIVAR.**The Stamps of 1879-1899.**

By A. HATFIELD, JR., and BERTRAM W. H. POOLE.

(Continued.)

The 5 Centavos.

The five types of this value differ in such minute particulars that it is sometimes a little difficult to discover the marks of identification. They are as follows:—

Type 1. (First Row).—A short faint line projects outwards from the upper part of the right hand frame about $\frac{1}{4}$ mm. below the top. This line is sometimes difficult to see. Directly over the left side of the top of the second upright stroke of the N of CINCO there is a very small white dot or rather indentation from the white band above the value label. On some stamps it is very faint. The line under the R of BOLIVAR is weak and often broken but this peculiarity can also be found on the stamps of the second row or type.

Type 2. (Second Row).—This type appears to have no special marks but it can be at once identified by the absence of the small peculiarities distinguishing the other types.

Type 3. (Third Row).—A short line projects diagonally from the left hand frame line about $\frac{1}{2}$ mm. from the top, and the line above the 7 of 1879 is always broken.

Type 4. (Fourth Row).—There is a decided roughness on the right side of the vertical stroke of the T of CENTAVOS which makes it bulge a little. It varies on some of the stamps of this row but is always present. There is also a faint uncolored line projecting diagonally from the right end of the upper stroke of the E of CORREOS.

Type 5. (Fifth Row).—The left hand frame line is broken for the space of nearly $\frac{1}{2}$ mm. immediately above the top line of the shield.

There are flaws on many of the stamps by which their positions on the sheet may be determined, but with the exception of the following they are too trifling to merit special mention.

No. 2.—An uncolored flaw is attached to the back of the A of COLOMBIA.

No. 33.—A colored flaw obliterates the top of the D of DE.

No. 38.—An uncolored flaw connects the tops of the letters OL of COLOMBIA.

No. 41.—The large central star on the band immediately below the portrait is joined by a colored line to the vertical line at right.

It is worthy of note that on every stamp on the sheet there is a small colored dot on the white line under the V of CENTAVOS while on most of the stamps the two side frame lines project slightly at the bottom of the design.

The 10 Centavos.

The five types of this value are as follows:

Type 1. (First Row).—There is a small colored dotted line or dash, about $\frac{1}{2}$ mm. in length, across the frame line on the left side of the stamp $7\frac{3}{4}$ mm. from the lower corner. There is a break in the outer frame line under this dash.

Type 2. (Second Row).—The line under the floral ornamentation to the left of the date is broken. There is a small colored dot in the narrow white band over the inscription at the top of the stamp. It is over the space between the DE and touches the outer colored line. It is missing on the sixth stamp.

Type 3. (Third Row).—There are two distinct colored lines or dashes in the L of BOLIVAR.

Type 4. (Fourth Row).—There is a small dash at the right side of the stamp slightly less than $\frac{1}{2}$ mm. in length. It is 1 mm. below the top and $\frac{1}{2}$ mm. outside and to the right of the right frame line. It is usually or possibly always missing on the 3rd, 7th, and 8th stamps although a slight trace of it can generally be found on the 3rd stamp. There is an uncolored flaw on top of the O of CENTAVOS resembling a broad white line cutting the two frame lines into the floral ornament in the lower left corner. Sometimes it is rather faint.

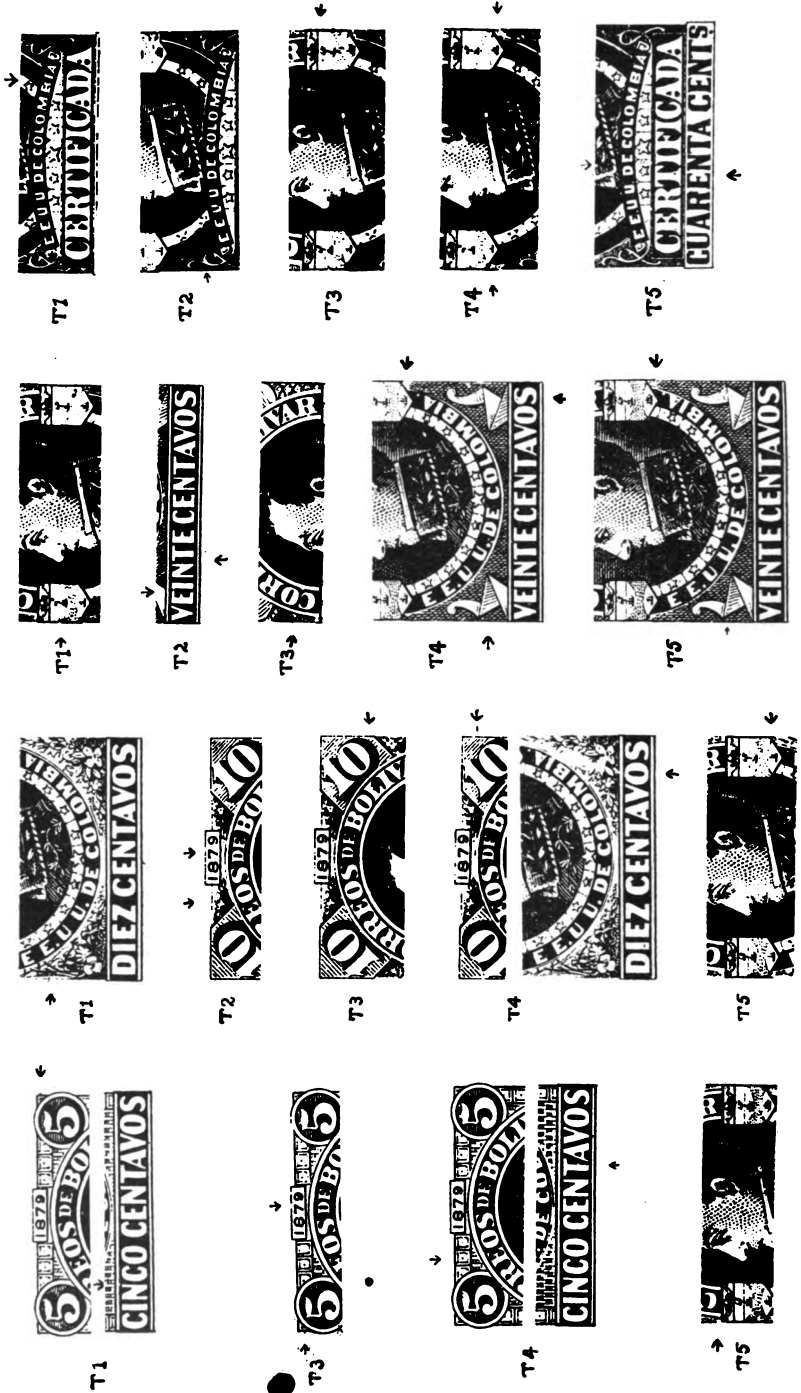

PLATE I.

Type 5. (Fifth Row).—The outside line of the right hand shield extends downwards and turns inwards towards the left.

The frame lines at the sides are generally weak or broken on most of the stamps on the sheets of this denomination.

The 20 Centavos.

The five types of this value are as follows:

Type 1. (First Row).—There is a small nick or indentation in the outer line of the left hand shield, just at the end of the line dividing the second and third sections of the shield.

Type 2. (Second Row).—A small uncolored line connects the tops of the letters E and I of VEINTE. A small uncolored dot or line projects from the centre of the right stroke of the second upright stroke of the N of the same word.

Type 3. (Third Row).—There is a tiny uncolored flaw on the color between the bottoms of the letters CO of CORREOS.

Type 4. (Fourth Row).—There is a colored dot in the upper part of the S of CENTAVOS and a white line between the period and DE on the inscribed band above. There is a prominent uncolored flaw on the shading of the sandle immediately below the shield at right.

Type 5. (Fifth Row).—The uncolored line below the inscription E E. U U. DE COLOMBIA touches some letters and is missing in places, and the frame line just below the right hand shield is more to the right than the rest of the design below. This type seems to show a certain amount of displacement in applying the bottom of the design to the centerpiece and is fairly satisfactory evidence that the designs were made on the transfer paper from separate dies for the portrait and frames as explained in our early notes.

There are two flaws on the sheet which call for special note, viz:—

No. 39.—A large uncolored dot joins the letters CE of CENTAVOS.

No. 46.—The centre of the 0 of 20 in the upper left hand corner is plainly malformed.

All the stamps on the second, fourth and fifth rows of the sheets of this value show a tiny uncolored dot between the two upper arms of the first E of VEINTE and most of the stamps show a slight projection of color on the left lower portion of the V of the same word.

The 40 Centavos.

The five types of the 40c are all very easily identified the marks of distinction being as follows:—

Type 1. (First Row).—The thick line of color below the shield at the right hand exudes on to the B of COLOMBIA.

Type 2. (Second Row).—The end of the thick line of color below the shield at the left is irregular and obliterates part of the lower of the two stars.

Type 3. (Third Row).—A small colored dot is shown to the left of the cap of liberty in the right hand shield. There is a flaw on the shading of the upper left corner immediately above the left end of the second R of CORREOS.

Type 4. (Fourth Row).—The shading on both sides immediately below the shields is weak and the lower portion of the design is slightly displaced so that it is moved a little to the right as compared with the upper half. There is a flaw on the shading of the upper left corner just above the centre of the first R of CORREOS.

Type 5. (Fifth Row).—There is a small colored circular line at the right of the second star below the portrait. There is a tiny colored dot on the lower part of the T of CERTIFICADA and a white projection to the right of this dot.

There are no flaws on the sheet of sufficient prominence to merit special description but it should be noted that on this value the border lines at the top and sides of the date are doubled.

Paper.

All four values exist on ordinary white wove paper and on bluish laid paper, though whether both varieties were in concurrent use or not we cannot say. In the "*Philatelic Record*" chronicle, only the white paper is mentioned and though diligent search has been made through various philatelic publications we have failed to find any reference to the bluish laid paper.

Perforation.

The stamps, on both kinds of paper, were perforated $12\frac{1}{2}$ with a single line machine.

Imperforate Varieties.

The 5c on white wove paper is fairly common imperforate and the other three values on wove paper and all four denominations on bluish laid paper are also known in this condition. To the best of our belief no genuine used copies of these imperforate specimens are known and none of them appear to have been mentioned in philatelic literature until some years after they had become obsolete. Apparently they were all found in the remainders of these Bolivar stamps and they can, perhaps, best be described as unfinished stamps. The 5c imperforate was first recorded in the "*Monthly Journal*" for November, 1892, but the varieties on bluish laid paper seem to have been quite unknown until 1905 when they were chronicled in the "*American Journal of Philately*."

Error of Color.

The 20c of this series is known printed in green instead of red. There is no green stamp in the set though a so-called essay for an 80c value was printed in this color as we shall show later. The earliest reference we can find to this variety occurs in an article by Mr. W. T. Curtis in the "*Metropolitan Philatelist*" for September, 1892, viz:—"I sometimes had the mortification of finding I had overlooked something rare, as happened in Cartagena, where although I had the privilege of examining the stamps, yet, as they were largely stuck together I did so carelessly, and thus overlooked a sheet of fifty of the 20 cents, 1879, printed in green. The sheet was discovered not long after and was given to the Governor of Bolivar, who is a stamp collector; by him they were divided with other collectors and by them quickly scattered, so that although I returned to Cartagena a few weeks after the discovery, yet it was only by hard work and a good price that I succeeded in getting a few of the stamps." The error was "rediscovered" two years later and was then somewhat generally reported in philatelic papers. Cancelled copies are known but whether these are legitimately used specimens or not we have no means of telling.

Essays.

In the 1880 series for Bolivar there are 80c and 1 peso stamps and it was evidently at one time intended to include these denominations in the 1879 set. The essay for the 80c was printed in sheets of fifty like the issued varieties. The stone does not appear to have been laid down in the same manner however; or, if five types do exist it is practically impossible to distinguish them. The sheets show numerous defects, especially in the letters of the inscription over the portrait. The shields at right and left often show breaks from the frame line, but more frequently at the right. At times the shields are slightly depressed from the frame line. The white semi circle over the head is very regular. This variety is only known perforated $12\frac{1}{2}$. It is known only on white wove paper. The essay for the 1 peso was printed in orange in vertical strips of five stamps. The types, from top to bottom of the strip, are as follows:—

Type 1.—The top of the B of BOLIVAR is broken, sometimes only very slightly. This, with the absence of the marks found on the other types, will distinguish this variety.

Type 2.—There is a large round blot of color directly over the left end of the small square in the lower right corner. It is very marked.

Type 3.—There are no marked variations to distinguish this type as it is similar to No. 1 with the exception that the top of the B is not broken.

Type 4.—There is a dot of color on the edge of the nose about 1mm. from the tip.

Type 5.—The nostril is a small dot instead of a line as on the other stamps. Sometimes on the white wove paper it is so faint as to appear absent altogether. Care should be taken not to confound the nostril with the shading under the nose.

This 1 peso essay is found imperforate on the white wove paper and perf. $12\frac{1}{2}$ on both white wove and bluish laid papers.

(To be continued.)



T1 ↓



T2



T3 ↓



T4



T5



PLATE II.

648999

THE POSTAL ISSUES OF AUSTRIA.

BY J. BRACE CHITTENDEN, Ph. D.

(Continued).

TABLE 20.

Complete Perforation Table, Issue of 1867.

| Perfs. | Kreuzer | | | | | Perfs. | Kreuzer | | | | | Mixed perfs. | |
|--------|---------|----|----|-----|------------|---------|---------|----|-----|-----|------------|--------------|---------------|
| | 2, | 3, | 5, | 10, | 15, 25, 50 | | 2, | 3, | 5, | 10, | 15, 25, 50 | | |
| 8½ | 2, | 3, | 5, | —, | —, | 10½:12½ | 2, | 3, | 5, | 10, | —, | —, | 2 Kr. |
| 8½:9 | —, | 3, | 5, | —, | —, | 10½:13 | 2, | —, | 5, | 10, | —, | —, | 10½:9½:10½: |
| 8½:10 | —, | —, | 5, | —, | —, | 11 | 2, | 3, | 5, | 10, | 15, | —, | 9½:10:10:1 |
| 8½:10½ | 2, | —, | 5, | —, | —, | 11:8½ | 2, | 3, | 5, | 10, | —, | —, | 9½:10:9½: |
| 8½:11 | 2, | —, | —, | —, | —, | 11:9 | 2, | 3, | 5, | 10, | —, | —, | 8½:9½:8½: |
| 9 | 2, | 3, | 5, | 10, | 15, 25, — | 11:9½ | 2, | 3, | 5, | 10, | —, | —, | |
| 9:8½ | 2, | 3, | 5, | —, | —, | 11:10 | 2, | 3, | 5, | 10, | —, | —, | 3 Kr. |
| 9:9½ | 2, | 3, | 5, | 10, | 15, 25, — | 11:10½ | 2, | 3, | 5, | 10, | 15, | —, | 10½:10½:10½:1 |
| 9:10 | —, | 3, | 5, | 10, | —, | 11:12 | 2, | 3, | 5, | —, | —, | —, | 8½:10½:9:1 |
| 9:10½ | 2, | 3, | 5, | 10, | —, | 11:12½ | 2, | —, | 5, | 10, | —, | —, | |
| 9:11 | 2, | 3, | —, | —, | —, | 11:13 | 2, | —, | 5, | 10, | —, | —, | 5 Kr. |
| 9½ | 2, | 3, | 5, | 10, | 15, 25, — | 11½ | 2, | 3, | 5, | 10, | 15, | —, | 8½:9:8½:1 |
| 9½:8½ | 2, | —, | 5, | 10, | —, | 11½:8 | —, | —, | 5, | —, | —, | —, | 8½:9½:9½: |
| 9½:9 | 2, | 3, | 5, | 10, | 15, 25, — | 11½:12 | 2, | 3, | 5, | —, | —, | 50 | 9:10:9: |
| 9½:10 | 2, | —, | 5, | —, | —, | 12 | 2, | 3, | 5, | 10, | 15, | —, | 10½:10:10: |
| 9½:10½ | 2, | 3, | 5, | —, | —, | 12:10½ | —, | —, | 5, | —, | —, | —, | 11:9:11: |
| 9½:11 | 2, | 3, | 5, | —, | —, | 12:11 | 2, | —, | 5, | —, | —, | —, | |
| 10 | —, | 3, | —, | —, | —, | 12:11½ | —, | 3, | 5, | —, | —, | —, | 10 Kr. |
| 10:9 | —, | 3, | 5, | —, | —, | 12:12½ | —, | 3, | 5, | 10, | 15, | —, | 8½:9½:9: |
| 10:9½ | —, | 3, | 5, | —, | —, | 12:13 | —, | —, | 5, | 10, | —, | —, | 11:10:10:1 |
| 10:10½ | 2, | 3, | 5, | 10, | —, | 12½ | 2, | 3, | 5, | 10, | 15, | —, | 50 |
| 10:11 | 2, | 3, | 5, | 10, | 15, — | 12½:10½ | —, | —, | 5, | 10, | —, | —, | 15 Kr. |
| 10:12½ | —, | —, | 5, | —, | —, | 12½:12 | —, | —, | 5, | —, | —, | 50 | 11:10½:10:1 |
| 10:13 | —, | —, | 5, | —, | —, | 12½:13 | 2, | 3, | 5, | —, | —, | 50 | |
| 10½ | 2, | 3, | 5, | 10, | 15, — | 13 | 2, | 3, | 5, | 10, | 15, | —, | 50 |
| 10½:8½ | 2, | 3, | 5, | 10, | —, | 13:10 | —, | —, | 10, | —, | —, | —, | |
| 10½:9 | 2, | 3, | 5, | 10, | 15, — | 13:10½ | —, | —, | 5, | 10, | —, | —, | |
| 10½:9½ | 2, | 3, | 5, | 10, | —, | 13:11 | —, | —, | 5, | 10, | —, | —, | |
| 10½:10 | 2, | 3, | 5, | 10, | 15, — | 13:12 | —, | 3, | —, | —, | —, | —, | |
| 10½:11 | 2, | 3, | 5, | 10, | 15, — | 13:12½ | 2, | 3, | 5, | 10, | —, | 50 | |
| 10½:12 | —, | 3, | 5, | —, | —, | 13:13½ | —, | 3, | —, | —, | —, | —, | |
| | | | | | | 13½:13 | 2, | —, | —, | —, | —, | —, | |

Measurements made first, horizontally, top and bottom, second, vertically, left and right.

The perforation 13 occurred in the year 1878. The rarest 8½, 9; less rare but still hard to obtain, 10½, 11½; very scarce, 12 and 13.

NOTE 10, Counterfeits. The 5k. red, Plate I is often found and frequently catalogued but never existed, or at least was privately obtained by perforating the corresponding envelope. The perforations 13½ and 14 are also held to be counterfeits. The so-called error 3 Kr. red is now considered to be a counterfeit, obtained by chemically changing other values.

In the year 1875 the Government began to plan a new issue because of a counterfeit of the 10K. blue which frequently passed the post. The pearls are 93 in number instead of 90 and therefore smaller, and the ribbons on the wreath are longer, and the back of the head has a slightly different shape. In May 1877 similar counterfeits or proofs appeared in all colors and were priced by Moens. They have a different form not only of the back head but in particular, the nose, which is sharp, and the forehead flat. Un-

der the upper third leaf of the wreath, the originals have two berries, whereas the counterfeit has but one. There are also a very large number of proofs in existence on all sorts of papers and in different colors, too numerous to mention (Kropf. p. 50-51), some of which are dangerously like the originals. There have been no reprints of this issue.

NOTE 11. Envelopes cut and used as Postage stamps. 1867.

| | | |
|-----------------|--------|----------|
| | Entire | On part. |
| 3K. green | — | 1.25 |
| 5K. red | — | 1.— |

SEVENTH ISSUE.



III. 86.

B. Used in Austria only. (See 6th issue).

From Sept. 1883 (except the 20K. which was in use from Aug. 1883) until June 30, 1891.

Illustration 86.

Double eagle with shield in the centre, which carries the figures of value in black; a small circle in the tail of the eagle with Kr.; above the small cellers, in a circle, "Kais. Konigl. Oesterr. Post", perforation 8½:13, watermarked Wmk. 3, Illustration 77 until 1891, during 1891 with Wmk. 4, Illustration 87.

TABLE 21.

Issue of 1883-91.

| | A-9½, 10 Rg. | B-9 (8½-10) | C-10½ (10¼-11) | D-11½, 12, 13 | E-Comp. |
|------------------------|-----------------|----------------|-------------------|------------------|---------|
| 34 2K. brown | | | | | |
| a 2K. yellow brown | .02 .01 | — 6.25 | — 1.50 | 10.00 10.00 | |
| b 2K. reddish brown | | | | | |
| 35 3K. green | | | | | |
| a 3K. yellow green | .04 .01 | — 3.75 | — 1.25 | 7.50 7.50 | — 10.00 |
| b 3K. blue green | | | | | |
| 36 5K. carmine rose | | | | | |
| a 5K. rose | .12 .01 | — — | — .75 | 1.50 1.00 | — 15.00 |
| b 5K. pale rose | | | | | |
| 37 10K. blue | | | | | |
| a 10K. ultramarine | .08 .01 | — 2.50 | — 1.25 | 8.75 8.75 | — 15.00 |
| b 10K. dark blue | | | | | |
| 38 20K. gray | | | | | |
| a 20K. greenish gray | .12 .05 | | — 3.75 | | |
| b 20K. dark gray green | | | | | |
| 39 50K. red violet | 1.25 .63 | | | | |
| a 50K. brown lilac | 1.25 .63 | | | | |
| b 50K. dull violet | 1.50 .63 | | | | |

NOTE 1. **Perforations.** $9\frac{1}{2}$ and 10 are regular (4 reg. corners), the perforation 10 varying from 10 to $10\frac{1}{2}$. The others are all line perforations, the $11\frac{1}{2}$ and 12 occurring only on the 5K. value; and of the line perforations there are only three distinct compounds, $9:10\frac{1}{2}$ (3K. and 5K.) and $10\frac{1}{2}:9$ (10K.). It follows that so far as perforations are concerned taking D and E together as one group, five sets are sufficient or eleven if the watermarks are considered, according to the following perforation table.

TABLE 22.

Perforation Table, Issue of 1883.

| Perf. Rg. | Kreuzer | | Line perf. Ir. | Kreuzer | | Comp. perf. | Kreuzer | |
|-----------------------|---------------------|--|-------------------|---------------------|--|-----------------------|---------------------|--|
| | 2, 3, 5, 10, 20, 50 | | | 2, 3, 5, 10, 20, 50 | | | 2, 3, 5, 10, 20, 50 | |
| A $9\frac{1}{2}$ (Rg) | 2, 3, 5, 10, 20, 50 | | B 9 | 2, 3, 5, 10, —, — | | E 9 : $10\frac{1}{2}$ | —, 3, 5, —, — | |
| A 10 (Rg) | 2, 3, 5, 10, 20, 50 | | C $10\frac{1}{2}$ | 2, 3, 5, 10, 20, — | | E $10\frac{1}{2} : 9$ | —, —, —, 10, — | |
| | | | D $11\frac{1}{2}$ | —, —, 5, —, —, — | | | | |
| | | | D 12 | —, —, 5, —, —, — | | | | |
| | | | D 13 | 2, 3, 5, 10, —, — | | | | |

For the sake of reference and completeness, but with renewed advice to collect by the foregoing tables only, the following table is added as given by Kropf, and the claim is made that it contains all known varieties discovered to date.

TABLE 23.

Complete Perforation Table, Issue of 1883.

| Perfs. | Kreuzer | | Perfs. | Kreuzer | | Mixed Perforation | |
|--------------------------------|---------------------|--|--------------------------------|---------------------|--|--|-------------------------------|
| | 2, 3, 5, 10, 20, 50 | | | 2, 3, 5, 10, 20, 50 | | | |
| $8\frac{1}{2} : 9$ | —, 3, —, 10, —, — | | $10\frac{1}{2}$ | 2, 3, 5, 10, 20, 50 | | 2 Kr. | |
| $8\frac{1}{2} : 9\frac{1}{2}$ | —, —, —, 10, —, — | | $10\frac{1}{2} : 9$ | —, —, —, 10, —, — | | 8 : $8\frac{1}{2} : 9$: | $9\frac{1}{2}$ |
| 9 : $8\frac{1}{2}$ | —, 3, —, 10, —, — | | $10\frac{1}{2} : 9\frac{1}{2}$ | —, —, —, 10, —, — | | 9 : 9 : $9\frac{1}{2} : 9$ | |
| 9 : $9\frac{1}{2}$ | 2, 3, —, 10, —, — | | $10\frac{1}{2} : 10$ | 2, 3, 5, —, 20, 50 | | $9\frac{1}{2} : 9$: | 9 : $8\frac{1}{2}$ |
| 9 : 10 | 2, 3, 5, —, —, — | | $10\frac{1}{2} : 11$ | 2, 3, —, —, 20, — | | 10 : $9\frac{1}{2} : 9$: | $9\frac{1}{2}$ |
| $9\frac{1}{2}$ | 2, 3, 5, 10, 20, 50 | | 11 | 2, 3, 5, 10, —, — | | 10 : $9\frac{1}{2} : 10$: | $8\frac{1}{2}$ |
| $9\frac{1}{2} : 9$ | 2, 3, 5, 10, —, — | | 11 : $10\frac{1}{2}$ | 2, 3, 5, —, —, — | | 3 Kr. | |
| $9\frac{1}{2} : 10\frac{1}{2}$ | —, 3, 5, —, —, — | | 11 $\frac{1}{2}$ | —, —, 5, —, —, — | | $8\frac{1}{2} : 10$: | 10 : 10 |
| 10 | 2, 3, 5, 10, 20, 50 | | 12 | —, —, 5, —, —, — | | $8\frac{1}{2} : 9\frac{1}{2} : 9\frac{1}{2} :$ | $9\frac{1}{2}$ |
| 10 : $8\frac{1}{2}$ | 2, —, —, —, —, — | | 12 $\frac{1}{2}$ | 2, —, 5, 10, —, — | | 9 : $9\frac{1}{2} : 9\frac{1}{2} :$ | $8\frac{1}{2}$ |
| 10 : 9 | —, 3, —, 10, —, — | | 12 $\frac{1}{2} : 13$ | 2, —, 5, —, —, — | | $9\frac{1}{2} : 9\frac{1}{2} : 9\frac{1}{2} :$ | $8\frac{1}{2}$ |
| 10 : $10\frac{1}{2}$ | 2, 3, —, 10, 20, 50 | | 13 | —, 3, 5, —, —, — | | $9\frac{1}{2} : 8$: | $9\frac{1}{2} : 9\frac{1}{2}$ |
| 10 : 11 | —, —, —, 10, —, — | | 13 : $12\frac{1}{2}$ | —, —, 5, —, —, — | | $9\frac{1}{2} : 9\frac{1}{2} :$ | $9\frac{1}{2} : 10$ |
| | | | | | | 5 Kr. | |
| | | | | | | $9\frac{1}{2} : 8\frac{1}{2} :$ | 9 : $9\frac{1}{2}$ |
| | | | | | | 10 : $9\frac{1}{2} :$ | 9 : 9 |
| | | | | | | 10 Kr. | |
| | | | | | | $8\frac{1}{2} : 9\frac{1}{2} :$ | 9 : $9\frac{1}{2}$ |

NOTE 2. There are no genuine imperforate stamps of this issue although a firm in Austria deliberately cut the perforations and used the stamps on letters, usually resulting in postage due charges. All others occurring are errors. Stamp No. 34 however exists with perforation $10\frac{1}{2}$ through the middle and No. 36 with perforation $10\frac{1}{2}$ on three sides and imperforate on the fourth. Pairs exist imperforate between, horizontally, but they are very scarce.

ZEITUNGS-MARKEN

III. 87.

NOTE 3. Watermarks. These stamps like the last type of the preceding issue are watermarked in sheets of 100 with the letters "BRIEF-MARKEN" Wmk. 3, Ill. 77, the word BRIEF above the word MARKEN, and specimens showing a trace of the letters are 5 times as scarce as the ordinary variety and those showing a complete or legible letter are very scarce. In April 1890 and shortly before the introduction of the next issue, the paper authorized for these stamps ran out and by a special decree the Office was empowered to use temporarily the paper manufactured for the newspaper stamps which always bore the letters "ZEITUNGS MARKEN", Wmk. 4, Ill. 87. They are long and thin like Wmk. 2 and the I. A. and K. are practically the same. Specimens showing Z, T, U, G or S are very highly prized and very hard to find. (April to Aug. 1890).

NOTE 4. Types: There are, in fact, two distinct types for each value. In Type 1 the figures are thin and in Type 2 the figures are thick.

NOTE 5. Errors. Those that occur are nearly all slight variations in type due to heavy or light printing or a poor centering of the figures of value or the word Kreuzer. It is, however, interesting to form a set with the word "KALS" instead of "KAIS" and the less frequent case "KONIGI" instead of "KONIGL" or a broken "O" at the top in "OESTERR" which occurs in all values. Again all values may occur in which the colored horizontal lines of shading in the background obviously pass over instead of under the words "KAIS. KONIGL. OESTERR. POST," and sets may be formed of each of them.

Special errors are:

- 2K. Left corner of the foot of the 2 missing (very rare).
Back of the 2 very flat (rare).
- 3K. Lower curve of the 3 nearly straight (rare).
Lower right loop of the 3 is shorter (rare).
- 5K. Curve of the 5 nearly straight.
The 5 on the edge of the shield (very rare).
- 10K. The 1 on the edge of the shield, on eagle (very rare).
Kr. outside the shield.

NOTE 6. In addition to the above a considerable number of essays are known most of which are described and illustrated in Kropf.

NOTE 7. It follows that a complete exhibit of this issue calls for the following sets:

- I perf. 9 ½ rg.
- II perf. 10 Rg.
- III perf. 9
- IV perf. 10 ½
- V perf. 11 ½, 12, or 13 or comp.
- VI Set Wmk. 3 (1883-1890)
- VII Set Wmk. 4 (1890-91)
- VIII Set error KALS instead KAIS.
- IX Set error KONIGI instead of KONIGL.
- X Set error colored lines over Kais.
- XI Set thin figures.
- XII Set thick figures.
- XIII Set rare errors.

NOTE 8. Reprints. 1892, 5K. red, Perf. 10 ½, price .05. The gum is yellowish and the number printed 10500. The last of the reprints of the postage stamps.

(To be continued.)



Published the 15th day of each month

J. KLEMANN, Jr., Editor.

CLIFTON A. HOWES, Special Contributing Editor.

JOHN A. KLEMANN, Managing Editor.

Staff Writers.

CHARLES LATHROP PACK

VICTOR M. BERTHOLD

J. MURRAY BARTELS

DR. CARROLL CHASE

A. E. OWEN

W. B. SPRAGUE

B. W. H. POOLE

SUBSCRIPTION \$1.00 A YEAR, SINGLE NUMBERS 10c.

Advertising Rates

| | 1 mo. | 3 mos. | 6 mos. | 9 mos. | 12 mos. |
|--------------|--------|--------|--------|---------|---------|
| 1 inch | \$1.50 | \$4.00 | \$7.75 | \$11.50 | \$15.00 |
| ¼ p. | 5.00 | 13.50 | 26.25 | 38.00 | 50.00 |
| ½ p. | 8.50 | 23.00 | 44.50 | 65.00 | 85.00 |
| 1 page | 15.00 | 40.50 | 78.75 | 114.75 | 150.00 |

NASSAU STAMP CO., Publishers, 118 NASSAU ST., NEW YORK.

VOL. V, No. 5.

NEW YORK, MAY, 1915.

WHOLE No. 69.

EDITORIAL.

The Stamp Market.

When one considers the great activity displayed in the New York Market during the past two months,—first the purchase of the extensive Krassa Stock by the Scott Stamp & Coin Co. followed closely by that of the Chapman Collection of United States by the Nassau Stamp Co.—one is immediately impressed with the thought that these two houses at least, are firm believers in the stability of stamps.

It is no small undertaking to make a purchase, the magnitude of either of these transactions, and the wonder of it all is that they were made at a time when most people were fearful that the market could not hold because of foreign conditions, which implied a glutting of the market.

Strange to say this condition of affairs has not occurred and the American market, instead of being called on to absorb European holdings let go at this time, finds nothing offered for sale, but instead, a steady demand for goods.

This state of affairs proves more than anything else could that the collecting of stamps is no longer merely a hobby or a temporary pastime but for men of affairs in times of stress, a healthy means of diversion.

SHORT NOTES AND NEWS.

Mr. Charles Lathrop Pack of Lakewood and Mr. Wm. H. Crocker of San Francisco are members of the World Court Congress Committee of One Hundred, which met in Cleveland, Ohio May 12, 13, 14, the object of which is to promote a true International Court of Justice for the judicial settlement of international disputes.

With the purchase of the well-known Chapman Collection of United States issues, the Nassau Stamp Co. has probably consummated the largest single purchase of United States stamps ever made.

The collection includes the Postmasters, Carriers and general issues and those who followed the International Exhibition in New York in 1913 will remember that Mr. Chapman was awarded two gold medals, one in Class B, Section 1, for his general issues, and one in Class B, Section 2, for his Postmasters and Carriers.

The collection will not be offered at auction, but is being sold at private sale.

Those who are interested in Europe and colonies exclusive of Great Britain and Colonies, will have an opportunity soon to purchase almost everything covered by this group. J. C. Morgenthau & Co. are offering in a series of June Sales one of the finest properties offered at auction in several years, and the result of practically twenty years collecting.

There was an exhibition of stamps in Zurich, Switzerland, May 12-16, the proceeds of which are to be devoted to the war sufferers. The principal exhibits were the postal issues incident to the war of 1914-15.

Coils & Imperforates.

No more coils of any kind are now being made joined endwise. There seems to be no longer any call for them from manufacturers or users of machines. A few, perhaps 50 of each, of the 4c and 5c joined endwise are still in the Bureau vaults, as well as some imperf. 5c in coils.

Only 1c and 2c stamps will now be supplied in imperforate sheets. The present 2c is a much lighter and brighter shade than formerly.

1890 Issue.

An old record book in the Washington Post Office Department contained a sample sheet of the 2c lake with "Carmine" written on the margin at top. Another sheet in the regular shade was similarly inscribed on margin, "Carmine Improved, Issued May 12, 1890."

In the last auction sale of the J. M. Bartels Co. held in April the U. S. issues brought surprisingly good prices.

The keenest competition, however, was on the 20th Century British Colonials, the used fetching exceedingly high prices and the unused following closely.

The last 44 lots in the sale were sold for the benefit of the sufferers in war-stricken Europe. The proceeds, without deductions were forwarded to the proper authorities and amounted to \$42.80.

Donations were received, with thanks, from the following:

| | | |
|---------------------|------------------|----------------|
| Hon. E. R. Ackerman | G. J. A. Folte | Mrs. E. Paiman |
| A. W. Bronson | Otto Haker | E. Sauers |
| C. G. Dietrich | Nassau Stamp Co. | Dr. C. F. Roh |

William Barry, the inventor of the stamp canceling machine, died in Oswego, New York, last week, aged 74. He was born in Fort Covington, Ky.

NEW ISSUE NOTES.

We reprint from the Colonial Journal the following information and list of new British Colonial stamps, issued during the last quarter.

British Honduras.—The 1, 2 and 5 cent stamps have been supplied overprinted with a design in special violet ink. The overprint covers the entire stamp, and was applied to distinguish the stamps, so that in the event of their being seized by an enemy in transit the stamps so marked could be declared invalid. The stamp of the 5 cent registration envelope is also overprinted in similar manner.

Gold Coast.—The 3d stamp, King George design, is now printed on C. A. yellow paper.

Kelantan.—\$1. The color of the border duty has been changed to singly fugitive brown, owing to the similarity of the \$1 green to the 1 cent stamp.

Nigeria.—A new supply of stamps is in course of printing in the same design and colors as the first issue. The 3d. and 4d. stamps will be printed on the C. A. yellow, the 1s. on the C. A. green, the 5s. on the C. A. yellow, and the 10s. on the C. A. green paper. The first issue of these values was on surface coloured white C. A. paper.

St. Vincent.—Owing to a temporary shortage of penny stamps the whole of the remaining stock of the 1s. stamps, King George design, black on green paper, i. e., 15,000 stamps, have been surcharged "One penny" in red ink. This overprint was applied in the colony.

Trengganu.—With reference to the change of colours the following new postage and revenue stamps have been supplied: 2 cents brown rose and brown, 4 cents green and Italian brown, 5 cents brown and grey, 10 cents red and green on yellow C. A. paper, all printed in singly fugitive inks; 25 cents purple and green, 30 cents black and purple, 3 dollars red and green on green C. A. paper; the head in the last three duties is printed in doubly fugitive inks. The first colour given is that of the frame containing the duty, and the second colour that of the portrait in each case.

It is not often that we are indebted to the daily newspaper for information regarding new issues, for as a general rule this information is supplied direct to the philatelic publications by their correspondents.

The New Yorker Staats Zeitung publishes the following two items of information:

Austrian Postage Stamps for Use in Poland.

The Austro-Hungarian Government has issued a series of stamps to be used in Poland. They are the Bosnian stamps with the head of the emperor, surcharged diagonally "K. u K. Feldpost."

So far the following denominations have been issued: 1, 2, 3, 5, 6, 10, 12, 20, 25 and 60h.

The Germans in Poland use the ordinary German stamps without any surcharge.

A new issue of Turkish stamps is in preparation. The government is unable to renew the supply of stamps of the present design because the plates were made, and still are in London.

Mr. Ed. Schmeckpeper, a well-known philatelist, temporarily residing in the State of Sinaloa, Mexico, in a letter to Mr. Bartels furnishes the following important information:

"The State of Sinaloa, on account of its occasional isolation, has availed itself of several surcharges on the primitive Centennial stamps of 1910 of Mexico. Besides the type set, quite common one, there exists first, and only used in Mazatlan, one typewritten as it appears, E. C.—Transito—rio, in three lines, and used on the 1c and 3c values from Sept. 26 to Oct. 5th, as far as I have been able to ascertain on a few very rare copies. Then the rubber stamp surcharge has been used on the same issue of stamps up to 20c in this State until provided with the type set surcharged ones, but also on the Transitorio stamps of early 1914 (also rare) from Nov. last, perhaps very sparingly and only by mistake on the 1, 2, 4, 5c values, in the beginning, when suddenly a week ago the 20c value turned up, cut diagonally in two and used as 10c. This I consider a great rarity. Further, undoubtedly through a misunderstanding at the Mazatlan Post Office, this rubber stamp surcharge was used on stamps of the Denver issue of which I possess the 1c stamp. No doubt some great rarities will also herein turn up.

UNITED STATES LOCAL STAMPS.

A Concise History and Memoranda.

COMPILED BY HENRY C. NEEDHAM.

(Continued.)

It was not until the latter part of the Company's career that Postage stamps were used. Following is a copy of a circular letter sent to all agents, which is self-explanatory.

"In answering this letter please refer to number.

No. 1,583.

San Francisco, Oct. 25, 1854.

To
Messrs. Adams & Co.
Stockton.

Gents:

To facilitate our business operations we have commenced the use of Express Postage Stamps as per sample enclosed.

There is no direct profit in them to any one. You will please cash them whenever presented at the rate of 25 cents each, and sell them at the same rate to pay postage and make small remittances. You will therefore persuade parties sending small sums to use them, although you will, of course, sell checks to any amount purchasers may wish, no matter how small, for we desire to be as accomodating as possible, but prefer the introduction of the Express Postage Stamp.

The present arrangement extends to California and Oregon only. Please do not use them in United States business.

Yours, etc.

ADAMS & CO.,
per E. Hal——"

From the foregoing circular it would appear that no stamps were issued prior to October, 1854, and that all of the emissions put out by the Company appeared between that date and February 25th, 1855. The stamps were clearly lithographed, and printed in sheets of 40; 5 vertical and 8 horizontal. Each sheet shows minor varieties as follows: the 30th stamp on the sheet shows a break in the plate, also dashes over figure 25 in lower right corner. On the 19th stamp there is a small unprinted square in the upper left corner below the figures of value. In almost every instance the stamps bear the signature of one of the following: L. R. (L. Reed); I. C. W. (I. C. Woods); E. Hal (—) and perhaps others. The head shown on each stamp is from a photograph of D. H. Haskell.

The stamp on pink card board, noted below, was never used for postal purposes. It was issued solely and entirely as currency, and was always so used. Many an old timer will tell you of playing poker and using these two bit stamps as chips. The Company realized a large income from the sale of these card board stamps as thousands of them were issued, and paid for, but never presented for redemption. Many of the postage stamps were likewise affixed to card board and used for similar purposes.



Type I.



Type II.



Type III.



Type IV.



Type V.



Type VI.

ADAMS & COMPANY.
(of California)

1854.

Net Market
Value

- Type I.
L1 25c Black on Blue paper.
Type II.
L2 25c Black on white initialed in Black Ink.
L2 25c Black on white initialed in Red Ink.
L2 25c Black on white Not initialed.
L2 25c Black on pink glazed surfaced card board.
L2 25c black printed on the white side of pink surfaced cardboard.
L2 25c Black on thin white wove paper, mounted on the reverse side of pink surfaced card board.
Type III.
L2 25c Black on white surcharged in red "Over our California lines only"
Type IV.
L3 25c Black on White, being Type II surcharged 25c per ½ oz.
Type V.
L3a 25c Black on White, Head within an octagon frame.
Type VI.
L4 No Value, Claret. For Newspapers only.

COUNTERFEITS.

We have never seen good counterfeits of any of the Adams stamps. The counterfeits called to our attention are poor lithographs or photogravures which are imperfect and very different from originals. It will not be necessary to distinguish or illustrate them.

(To be continued.)

CHECK LIST OF U. S. STAMP BOOKS.

COMPILED BY W. H. DOLE.

Revised April, 1915.

Series of 1898.

| Check List. | Stamp. | Color of Cover. | Remarks. |
|-------------|--|-----------------|--|
| Spec. | 2c orange red. | | |
| a | S I | " " | Printed in (a) black; (b) green; (c) red. 240 issued April 16, 1900. stamps and covers surcharged "Specimen" (hand stamped). |
| b | S II | " " | |
| c | S III | " " | |
| d | S I | " " | Covers are from same printing as 1g, 1h, 1i but grooved to form a hinge, and covers and stamps surcharged "Specimen". |
| e | S II | " " | |
| f | S III | " " | |
| 1. | 2c orange red, rosy red. (Double lined watermark). | | |
| a | S I | " " | Printed in black. |
| b | S II | " " | Printed in green. |
| c | S III | " " | Printed in red. |
| d | S I | " " | Similar to a, b, c but covers all printed in black. |
| e | S II | " " | |
| f | S III | " " | |
| g | S I * | " " | Similar to d, e, f but with large price numerals on covers. |
| h | S II * | " " | |
| i | S III * | " " | |
| j | P I * | " " | Similar to g, h, i; watermark on stamps reads sideways instead of normal as in previous issues. |
| k | P II * | " " | |
| l | P III * | " " | |
| m | P I * | " " | "THE REGISTRY SYSTEM" 27m.m. long instead of 20m.m. as on previous covers (a to l inc.). |
| n | P II * | " " | |
| o | P III * | " " | |

Series of 1902-3.

| | | | |
|----|---------------------------------------|-----|---|
| 2. | 1c green, dark green. | | |
| a | M II | " " | Issued Mar. 6, 1907. "THE REGISTRY SYSTEM" 28m.m. 12 lines of printing on 2nd cover page. |
| b | M II | " " | |
| c | M II | " " | |
| d | M II | " " | |
| e | M II | " " | |
| 3. | 2c carmine, carmine rose (Flag type). | | |
| a | P I * | " " | Issued Feb. 11, 1903. Covers same as 1m, n, o. |
| b | P II * | " " | |
| c | P III * | " " | |

| | | | | | | | |
|----|---|--|---|---|---|--------|---|
| 4. | | 2c carmine, scarlet, carmine lake, etc. (Shield Type). | | | | | |
| a | P | I | * | " | " | Buff | } Issued Nov. 18, 1903. Covers same as 1m, n, o. |
| b | P | II | * | " | " | Yellow | |
| c | P | III | * | " | " | Gray | } |
| d | W | I | | " | " | Buff | |
| e | W | II | | " | " | Yellow | } |
| f | W | III | | " | " | Gray | |
| g | C | I | | " | " | Buff | } |
| h | C | II | | " | " | Yellow | |
| i | C | III | | " | " | Gray | } |
| gg | C | I | | " | " | Buff | |
| hh | C | II | | " | " | Yellow | } |
| ii | C | III | | " | " | Gray | |
| j | C | I | | " | " | Buff | } |
| k | C | II | | " | " | Yellow | |
| l | C | III | | " | " | Gray | } |
| m | M | I | | " | " | Buff | |
| n | M | II | | " | " | Yellow | } |
| o | M | III | | " | " | Gray | |
| mm | M | I | | " | " | Buff | } |
| nn | M | II | | " | " | Yellow | |
| oo | M | III | | " | " | Gray | } |
| p | M | I | | " | " | Buff | |
| q | M | II | | " | " | Yellow | } |
| r | M | III | | " | " | Gray | |
| s | M | I | | " | " | Buff | } |
| t | M | II | | " | " | Yellow | |
| u | M | III | | " | " | Gray | } |
| v | M | I | | " | " | Buff | |
| w | M | II | | " | " | Yellow | } |
| x | M | III | | " | " | Pink | |
| y | M | III | | " | " | Gray | (See No. 2d and 2e). |

Series of 1908.

| | | | | | | | |
|----|----|-----------|--|---|---|-------|--|
| 5. | | 1c green. | | | | | |
| a | M | II | | " | " | Green | } Issued Dec. 3, 1908. Cover same as No. 2c. |
| b | M | II | | " | " | Green | |
| c | M | II | | " | " | Green | } Cover same as No. 2d. Cover same as No. 2e. |
| d | PO | II | | " | " | Green | |

| | | | | | | | |
|----|----|------------|--|---|---|--------|---|
| 6. | | 2c carmine | | | | | |
| a | M | I | | " | " | Buff | } |
| b | M | II | | " | " | Yellow | |
| c | M | III | | " | " | Gray | } |
| d | M | I | | " | " | Buff | |
| e | M | II | | " | " | Yellow | } |
| f | M | II | | " | " | Pink | |
| g | M | III | | " | " | Gray | } |
| h | M | III | | " | " | Gray | |
| i | PO | I | | " | " | Buff | } |
| j | PO | II | | " | " | Pink | |
| k | PO | III | | " | " | Gray | } |
| | | | | | | | |

Series of 1910.

| | | | | | | | |
|----|----|----------|--|---|---|---------------------------|---|
| 7. | | 1c green | | | | (Single lined watermark). | |
| a | PO | II | | " | " | Green | } Without hours of delivery on 2nd page. |
| b | PO | II | | " | " | Green | |

| | | | | |
|------------------------|-------------|---|---|--|
| 8. | 2c carmine. | | | (Single lined watermark). |
| a | PO I | " | " | Buff |
| b | PO II | " | " | Pink |
| c | PO III | " | " | Gray |
| d | PO I | " | " | Buff |
| e | PO II | " | " | Pink |
| f | PO III | " | " | Gray |
| | | | | } Without hours of delivery on 2nd page. |
| | | | | } With hours of delivery on 2nd page. |
| Series of 1912. | | | | |
| 9. | 1c green. | | | |
| a | PO II | " | " | Green Issued Feb. 8, 1912. 16 lines of printing on third cover page. |
| b | PO II | " | " | Green Same as 9a except hours of delivery included on 2nd page. |
| c | PW II | " | " | Green Issued Sept. 1913. 18 lines of printing on third cover page. |
| d | PW II | " | " | Green 17 lines of printing on third cover page. |
| e | PW IV | " | " | Purple Issued Jan. 30, 1914. 17 lines of printing on third cover page. |
| 10. | 2c carmine. | | | |
| a | PO I | " | " | Buff |
| b | PO II | " | " | Pink |
| c | PO III | " | " | Gray |
| | | | | } Issued Feb. 14, 1912. 16 lines of printing on third cover page. 396 copies of No. 10a were issued experimentally with grided waxed paper between stamps, instead of regular waxed paper. |
| d | PO I | " | " | Buff |
| e | PO II | " | " | Pink |
| f | PO III | " | " | Gray |
| | | | | } Same as 10a, b, c except hours of delivery included on 2nd page. |
| g | po I | " | " | Yellow |
| h | po II | " | " | Pink |
| i | po III | " | " | Blue |
| | | | | } Printed in red; 18 lines of printing on third cover page. |
| j | po I | " | " | Yellow |
| k | po II | " | " | Pink |
| l | po III | " | " | Blue |
| | | | | } 17 lines of printing on third cover page. |
| 9-10. | 1c and 2c. | | | Combination book. |
| a | PW V | " | " | White Printed in red; 17 lines of printing on third cover page. |
| Series of 1914. | | | | |
| 11. | 1c green | | | Stamps perf. 10 instead of 12 as before. |
| a | PW II | " | " | Green Cover same as No. 9d. |
| b | PW IV | " | " | Purple Cover same as No. 9e. |
| 12. | 2c carmine. | | | Stamps perforated 10 instead of 12 as before. |
| a | po I | " | " | Yellow Cover same as No. 10j. |
| b | po II | " | " | Pink Cover same as No. 10k. |
| c | po III | " | " | Blue Cover same as No. 10l. |
| 11-12. | 1c and 2c. | | | Combination book. |
| a | PW V | " | " | White Cover same as No. 9-10a. |

*Also surcharged "PHILIPPINES" on stamps and cover.

Reference.—Post Master Generals and terms of office etc.

S—Chas. Emory Smith, April 22, 1898.

P—Henry C. Payne, Jan. 15, 1902; (died Oct. 4, 1904).

W—Robert J. Wynne, Oct. 10, 1904.

C—Geo. B. Cortelyou, Mar. 7, 1905.

M—Geo. von L. Meyer, Mar. 4, 1907.

PO—Post Office Seal (horseman), Frank H. Hitchcock, Mar. 6, 1909.

po—Post Office Seal (horseman) smaller, printed in color (red); Albert S. Burleson, Mar. 5, 1913.

PW—Washington P. O. building in small seal instead of horseman; printed in dark green or red.

Reference.—Type I, Book of 12 stamps (2c-25c)

Type II, Book of 24 stamps (1c-25c, 2c-49c)

Type III, Book of 48 stamps (2c-97c)

Type IV, Book of 96 stamps (1c-97c)

Type V, Book of 48 stamps (24-1c and 24-2c combination book —73c)

Note—There were no stamp books issued with special surcharge for Cuba, Porto Rico, Canal Zone, Guam or Hawaii.

Note—Stamps in books issued under P. M. G. Smith (No. 1a to 1i inc.) have normal watermark; in all following books the wmk. reads sideways.

Note—Thin white tissue paper used to separate stamps in Spec. book "a" and in No. 1a. Waxed amber paper used to separate stamps in Spec. book "b" and "c". Thick yellowish waxed paper in Spec. d, e, f, No. 1b, c, d, e, f, g, h, i, j, k and l. White waxed paper in No. 1m and all following books, except No. 10a in 396 of which a patented grilled waxed paper was used.

Note—The above information was gathered mostly from books in my own collection of which 90 varieties were obtained with stamps and covers complete.

Note—No. 1c is found bound with both one large or two smaller metal staples, all others are fastened with two staples.

Note—The existence of several books listed originally in the Philatelic Gazette (Oct. 1911) was assumed, but are omitted from the present list as they have not been found.

Corrections or additions to the above list invited.

AUCTION REPORT.

J. C. Morgenthau & Co. 94th Sale.

Lot No.

| | | |
|-----|---|-------|
| 8 | U. S., 1851, 1c blue, Type III (32), lightly cancelled | 18.50 |
| 11 | — 5c red brown (34), lightly cancelled, | 10.75 |
| 45 | — 1870, 12c dull violet (140), used, | 42.50 |
| 437 | — Navy, 2c black, imperf. on regular paper, Proof, block of 4, | 24.50 |
| 459 | — Revenues, 1862 imperf., \$25.00 Mortgage, | 17.50 |
| 471 | — 1871 Second Issue 10c blue and black, Center inverted, uncancelled, | 19.00 |
| 491 | — 1899, \$500.00 carmine and black (3044), unused, | 31.00 |
| 688 | Guadeloupe, 10c on 40c red (46), the variety with figures "10" hand stamped, unused, o. g., | 16.00 |
| 754 | Ivory Coast, 1903, 4f on 60c brown (167), unused, o. g., | 17.50 |
| 758 | — 4f on 1f rare type italic "4", unused, o. g., | 21.00 |

Lot No.

J. C. Morgenthau & Co. 95th Sale.

| | | |
|-----|--|-------|
| 36 | Barbados, 1873, Large Star, 6p vermilion imperf. (41a) used, | 20.50 |
| 40 | — 1878, 1p on left half of 5s dull rose reading up (57), used, | 23.00 |
| 41 | — 1p on right half of 5s dull rose, reading up (57), used, | 23.00 |
| 42 | — 1p on left half of 5s dull rose, reading down (57), used, | 23.00 |
| 55 | British Columbia, 1865, CC, imperf. 10c blue (4), used, | 15.50 |
| 76 | British Honduras, 1888, 50c on 1s gray (25), used, | 16.50 |
| 96 | Cape of Good Hope, 1853, blued paper, 1p red (1), pair used, | 8.50 |
| 101 | — 1855 white paper, 1p rose (3), pair, used, | 7.10 |
| 108 | — 6p lilac (5), pair, used, | 13.50 |
| 110 | — 6p gray (5a), pair, used, | 13.10 |

| | | |
|-----|---|-------|
| 113 | — — 1s yellow green (6), pair, used, | 20.00 |
| 117 | — — 1s deep green (6a), pair, used, | 22.00 |
| 119 | — — 1p vermilion (7), pair, used, | 88.00 |
| 120 | — — 4p pale blue (9), lightly cancelled, | 17.50 |
| 121 | — — 4p pale blue (9), pair, used, | 71.00 |
| 122 | — — 4p bright blue (G20), used, | 17.50 |
| 123 | — — 4p gray blue, retouched corner (G22b), used, | 76.00 |
| 133 | — 1863 De La Rue, 6p violet (14), pair, used, | 12.50 |
| 137 | — 1882 CA, 5s orange (38), used, | 8.20 |
| 196 | Gold Coast, 1889, 20s green and carmine (23), used | 43.50 |
| 246 | Mauritius, 1859, 2p blue (17), used, | 10.50 |
| 270 | Nevis, 1861 blued paper, 4p dull rose (2), unused, | 24.00 |
| 285 | New Brunswick, 1851, 6p yellow (2), used, | 15.00 |
| 287 | — — 1s red violet (3), used, | 73.00 |
| 310 | Nova Scotia, 1851, 6p dark green (5), used on original, | 15.90 |
| 311 | — — 1s red violet (6), used, | 54.00 |
| 312 | — — 1s dull violet (7), used, | 72.50 |
| 409 | Tobago, 1880, 1p on right half of 6p orange (7), used on piece of original, | 21.25 |
| 412 | — — 6p bistre brown (11), used, | 14.25 |
| 459 | Sicily (Bomba Heads), Plate I, 1 Grano dark olive brown, horizontal pair, used, the right hand stamp retouched, | 18.00 |
| 464 | — Plate II, 1 Grano Olive brown, horizontal strip of 4, used, | 21.00 |
| 467 | — — — dark olive green, horizontal pair, used, | 10.00 |
| 474 | — Plate III, 1 Grano olive green, horizontal strip of 5, Nos. 11 to 15 in plate, used, | 27.00 |
| 476 | — Plate I, 2 Grana blue, upper half of plate reconstructed, except Nos. 6 and 7, used, | 41.00 |
| 477 | — — — lower half of plate reconstructed except 10 stamps, used, | 36.00 |
| 486 | — Plate II, 2 Grana blue, identified in plate, 34 stamps, used, | 31.00 |
| 507 | — 10gr deep blue, retouch in figure "0" at bottom, used, | 12.50 |
| 510 | — 50gr dark brown red (18), oily print, unused, o. g., | 12.75 |

J. C. Morgenthau & Co. 96th Sale.

| | | |
|------------|--|-------|
| Lot No. | | |
| 1 | U. S., 1847, 5c red brown (28), cancelled red "10" "10" on cover, | 14.50 |
| 6 | — — 5c red brown (28), vertical pair, both variety dot in "S" on cover, | 19.50 |
| 7 | — — 5c red brown (28), vertical pair, on cover, | 8.25 |
| 24 | — 1857, 1c blue, type 4, (42C), horizontal strip of 3, on cover, | 10.50 |
| 53 | — Navy, 3c blue on cover, | 4.30 |
| 73 | Confederate States, 1862, 2c green (202) on cover, | 7.50 |
| 126 | Colombian Republic, 1860, 5c gray blue, 10c red brown (6, 8), on cover, | 12.00 |
| 127 | — — 5c violet, 10c buff (7, 9), on cover, | 13.50 |
| 128 | — — 10c buff (9), horizontal pair, on cover, | 11.50 |
| 136 | France, 1853, 80c rose, Pin perf. (20b), 3 copies on cover, | 15.25 |
| 137 | — 1870, 20c, 40c (51, 53) on Balloon Letter, | 8.75 |
| 175 | Mexico, 1861, 2r pink (8), and diagonal half of 2r pink (8b), on cover, | 19.50 |
| 275 | U. S., 1857, 10c green Type II (50a), block of 11, unused, o. g., | 45.50 |
| 348 | — Revenues, Perf. \$200.00 green and red, block of 6, pen cancelled, | 61.00 |
| 428 to 435 | Canada, 1908, set ½c-20c (96-103), imperf. vertical pairs, unused, o. g., | 84.00 |
| 472 | Ceylon, 1857, 1s9p green (12), used, | 30.50 |
| 485 | — 1861, 2s blue (36), used, | 8.10 |
| 512 | Colombian Republic, 1865, 5c (37), horizontal pair; 1866, 5c (45), horizontal strip of 3; 1870, 5c; 1876, 20c (62, 75) horizontal pair of each, all used, | 7.75 |
| 538 | Puerto Principe, 1898, 5c on ½m blue green (192), horizontal pair, with marginal strip between with surcharge of the rare type (193), used on piece of original, | 27.00 |
| 637 | Bavaria, 1848, 6kr. brown (3), block of 4, cancelled, "148", | 8.50 |

SOCIETY NOTES.

Collector's Club.

The April meeting and monthly competitive exhibition were held on April 29th with eighteen members present. Seven new members were admitted.

The exhibition for the evening called for German Colonies and the collection of Mr. H. G. Zervas was awarded the first ribbon followed closely by that of Sen. E. R. Ackerman which received the second.

The judges were Messrs. J. M. Bartels, A. Burger and G. Burger.

The May meeting will be held May 27th; competitive exhibition, Any Republic in Central or South America.

The Philadelphia Stamp Club.

The Philadelphia Stamp Club held its first April meeting on April 2, 1915, in the Club room, 34 So. 16th St., under the guidance of the Vice President, Mr. Mecutchen, with 22 members and 3 visitors present. After the regular routine business Mr. Klein of the Entertainment Committee introduced Mr. Joseph B. Leavy of Washington, D. C. as the lecturer for the evening, stating that Mr. Leavy, once an earnest collector of U. S. stamps had done much in furtherance of our knowledge of these stamps, especially through his study of the New York 5c stamp of 1845.

Mr. Leavy himself said that he had given up his collection of U. S. stamps some years ago, and had been devoting his time since then to collecting the stamps of such countries, which had been paid little attention by other collectors, as for instance the stamps of Belgium.

However, in his position as Government Philatelist he had access to all the plates used in printing the U. S. stamps, and had discovered two varieties of the U. S. \$1.00 black, 1894 type, of which stamps he displayed a number of fine specimens, proving his discovery.

After this Mr. Leavy displayed his specialized collection of Belgian stamps, a collection, which certainly was admired by all present. A rising vote of thanks was rendered Mr. Leavy for his most interesting and instructive lecture.

On April 20th the Club held its Annual meeting and banquet at the Windsor Hotel and 55 members and visitors gathered round the tables prepared for this occasion. About 8 o'clock the President, Mr. Hahman, called the regular meeting to order, thanking in hearty words the chairman of the Entertainment Committee, Mr. Wolter, for his endeavor to make this meeting such a success.

Mr. A. F. Henkels in the name of the Philadelphia Stamp Club then thanked the Secretary and Auction Manager for all the work they had done for the Club during the last year and presented each one with a fine Krassa Album. Mr. Henkels himself was then presented by the Club with a nice pipe in appreciation of his work as Exchange Manager.

The election of Officers for the year 1915-16 was then in order and the result of the election was as follows:

President: F. Hahman
 Vice President: Robt. D. Craighead
 Secretary: Karl L. Hassel
 Treasurer: Prof. J. L. Neufeld
 Librarian: Julius H. White
 Sales Mgr.: W. S. F. Pierce
 Auction Mgr.: James Whiteside
 Exchange Mgr.: A. F. Henkels
 Directors: C. E. Brinton, E. L. Green, Eugene Klein, J. R. Wolter,
 P. M. Wolsieffer.

As Messrs. Lyons and Klein had donated some stamps to be sold for the benefit of the Club an impromptu auction sale was held, the outcome of which was added to the rent fund.

After this Mr. Percy McG. Mann gave a lecture on the stamps of Austria, exhibiting at the same time his collection of the stamps showing all the issues in the different types, grades of paper, shades, etc. including some

rare varieties. A hearty vote of thanks was rendered Mr. Mann for his very interesting and instructive lecture.

At the Board of Governors meeting which was held on April 23 the different committees were appointed. Mr. Percy Mann was nominated as Chairman of the Entertainment Committee and promised some great features for the coming year. Mr. Mecutchen was elected by acclamation as Bourse Manager.

KARL L. HASSEL, Secretary.

REVIEW.

Who's Who In Philately—1915.

This, the second edition of a work whose title suggests the contents and scope of the subject matter, is much enlarged and a considerable improvement on the former edition.

While it is practically an impossibility to include all persons of renown in the realm of philately, the author deserves great credit for having accomplished as much as he did.

Most of those mentioned are well known and have an international reputation and yet, the omission of many Americans, prominent in the U. S. at least, is noticeable.

As a contribution to the bibliography of philately it is a valuable addition giving as it does, intimate information regarding those who collect stamps and showing what manner of men they are.

Who's Who in Philately—1915 by Albert H. Harris. Published by the Philatelic Circular, 42 Fieldhouse Road, Balham, London, S. W., England. Bound in cloth with leather back. 18 + 89 + 1 pp. Price 2sh6p net.



NE PLUS ULTRA.

Made in America

Interchangeable Leaves
BLANK ALBUMS - \$4.00 and up
STOCK BOOKS - \$2.00 and up

Used by the foremost Collectors and Dealers
 Complete price list free on request



"Ne Plus Ultra" Watermark Revealer
 Price 50c. Postage 10c. extra

All "Ne Plus Ultra" supplies manufactured exclusively by
SCOTT STAMP & COIN CO.
 127 Madison Ave. New York City

98th SALE

June 15, 16, 17, 1915

EUROPE—PART I

Austria — Hungary — Bosnia
 Belgium — Bulgaria — Denmark
 Danish West Indies — Iceland
 France

Catalogue mailed on request.

J. C. Morgenthau & Co.
 87 Nassau St. New York City

Confederates

Locals and Carriers

What have you to offer?

Send at your lowest cash price.

JOHN A. KLEMANN
 118 Nassau St. New York

U. S. BLOCKS

CANADA

A favorable acquisition enables us to offer some very fine U. S. in blocks of four at quite reasonable rates. We are also quoting prices on single copies. The shades named are in accordance with the U. S. Official Catalogue of the A. P. S. (see Philatelic Gazette and American Philatelist).

All centered, no straight edges, unused, o. g.

| | Singly | Blk.4 |
|------------------------------|--------|-------|
| 1890 1c common shade | \$.04 | \$.25 |
| 1c violet ultramarine | .40 | 1.50 |
| 2c carmine | .06 | .35 |
| 2c deep carmine lake | .12 | .60 |
| 2c lake | .30 | 1.50 |
| 3c bright violet | .08 | .40 |
| 4c dark brown | .11 | .50 |
| 5c deep orange brown | .15 | .60 |
| 6c common shade | .15 | .80 |
| 6c rose brown | .30 | 1.35 |
| 10c dull green | .23 | 1.00 |
| 15c indigo | .35 | 1.60 |
| 30c full black | .60 | 3.00 |
| 90c common shade | 1.60 | 7.00 |
| 1894 50c red orange | 1.25 | 5.00 |
| 1895 1c dark blue | .06 | .35 |
| 2c type III pink | .06 | .30 |
| 3c purple violet | .08 | .40 |
| 4c deep black brown | .10 | .45 |
| 5c orange brown | .15 | .70 |
| 6c deep dull claret brown | .20 | 1.00 |
| 8c brownish purple | .15 | .80 |
| 10c dull green | .25 | 1.25 |
| 15c indigo | .35 | 1.60 |
| 50c orange | 1.25 | 6.00 |
| \$1 black | 1.40 | 6.00 |
| \$2 light dull blue | 3.00 | 12.00 |
| \$5 dull green | 6.25 | 25.00 |
| 1898 5c (Grant) blue | .12 | .60 |
| 1902 \$1 black | 1.50 | 6.00 |
| \$2 dark blue | 2.60 | 10.00 |
| \$5 deep blue green | 6.00 | 24.00 |

We can furnish all modern U. S. in blocks, also many older issues. Send us your

Want List in U. S.

We carry a splendid stock, unused and used, regular issues, Departments, Dues, Newspaper, and especially Envelopes, cut square and entire.

J. M. BARTELS CO.,
99 Nassau St., N. Y.

| | Cat. | Net |
|------------------------------------|--------|------|
| 1852—3p red, imperf | .60 | .40 |
| 1858—10p blue, fine | 10.00 | 7.00 |
| 1859—10c lilac, shades | 1.00 | .50 |
| 1868—Any value, 1c to 15c incl. | — | .35 |
| 1872—10c rose-li'ac, scarce | .60 | .35 |
| 1908—"Quebec" set, mint | (1.34) | 1.30 |

ALL ABOVE ARE IN FINE
CONDITION

What else do you want?

B. L. VOORHEES

La Grange, Illinois

Biggest philatelic monthly, THE WEST, offers one dozen choice western post cards or standard illustrated coin book with buying prices selling at 15c. Pick either one free with two months' trial subscription, 200 pages, only 10c. Stamps, coins, curios, relics, minerals, old books, weapons, and most all hobbies dealt with. For over ten years averaged 100 pages per issue. Official organ fastest growing stamp society, S. P. A. Past two years more new members than any three other U. S. societies combined. Yearly subscription including 20-word ex. adv. free for 75c. Or send \$1.10 and get oldest stamp dealer's catalog. (Lincoln's). Sent direct from London. Has U. S. illustrated, with maps, etc., and lists there at 85c. Advs. pay big. 3c a word in largest trade and want columns extant. Do it now. Send for sample copy.

PHILATELIC WEST

Superior

Nebraska

PHILATELIC^{THE} GAZETTE

PUBLISHED MONTHLY FOR STAMP COLLECTORS

VOL. V, No. 6

NEW YORK, JUNE, 1915.

WHOLE No. 70.

SPECIAL PRINTING OF DIE PROOFS FOR THE SAN FRANCISCO EXPOSITION.

BY JOSEPH B. LEAVY.

In 1912, by order of the Postmaster General, all stamps, proofs, etc. in the Post Office Department were turned over to the U. S. National Museum, and therefore to make a fitting exhibit of United States stamps at the San Francisco Exposition the Post Office Department found it necessary to order a special printing of die proofs from the Bureau of Engraving and Printing. But two sets of these proofs were issued; one is in the Post Office exhibit at San Francisco, and the other was donated by the Post Office Department to the U. S. National Museum.

As this set has just been mounted and placed on exhibition at the Museum I thought a list and description, with some historical data concerning the dies, would be of interest to philatelists, more especially as the proofs were the cause of some very foolish statements by "Don B" in "Mekeel's Weekly Stamp News" for March 13th. The proofs are all printed on white india paper.

CARRIER STAMPS—1851

Franklin, blue

Eagle, blue

Both of the above proofs are Government imitations, printed from dies made at the Bureau of Engraving and Printing in 1903 for the special printing of die proofs issued in 1904 in albums.

The original die for the Eagle stamp in the possession of the Bureau had a horizontal crack through the impression. A transfer was taken from the original die, all traces of the crack carefully removed from this transfer and a new die made from it.

The original die of the Franklin stamp was not in the possession of the Bureau so a die was made by taking a transfer of the head from the die of the 30 cent stamp of 1851-57, a transfer of the frame from the 3 cent stamp of the same issue removing the top and bottom labels and the ornaments in the corners outside of the rosettes, impressing these transfers upon a new die, and engraving the top and bottom labels and ornaments outside of the rosettes directly on this new die, the ornament outside of the upper right rosette being omitted through an oversight.

GENERAL ISSUES

1847

5c brown, yellow brown

10c black

Both of the above proofs are Government imitations, being printed from the dies engraved by the Continental Bank Note Company in 1875 for the Centennial Exhibition at Philadelphia in 1876.

1851-57

| | | |
|------------------|----------------|---------------|
| 1c dark blue | 10c deep green | 30c orange |
| 3c deep dull red | 12c black | 90c deep blue |
| 5c red-brown | 24c lilac | |

Printed from the original dies engraved by Toppan, Carpenter & Co. of Philadelphia.

AUGUST 1861

| | | |
|----------------|----------------|----------|
| 1c indigo | 24c deep lilac | 90c blue |
| 10c dark green | 30c red-orange | |

Printed from the original dies engraved by the National Bank Note Company for the September 1861 issue.

| | | |
|-------------|----------|-----------|
| 3c rose-red | 5c brown | 12c black |
|-------------|----------|-----------|

The above three proofs are Government imitations, printed from dies made by the Bureau of Engraving and Printing in 1903 for the special printing of die proofs issued in 1904 in albums. Transfers were taken from the original dies for the September, 1861 issue, the corner ornaments cut away and new dies made from the altered transfers.

SEPTEMBER 1861

| | | |
|-----------------|-----------------|-------------------|
| 1c pale blue | 10c light green | 30c yellow-orange |
| 3c rose-red | 12c black | 90c blue |
| 5c olive yellow | 24c red-lilac | |

Printed from the original dies engraved by the National Bank Note Co.

1862-66

| | | |
|------------|----------------------|-----------|
| 2c black | 5c deep yellow-brown | 24c lilac |
| 3c scarlet | 15c black | |

Printed from the original dies engraved by the National Bank Note Co.

1869

| | |
|----------------|----------------------------------|
| 1c buff | 10c yellow orange |
| 2c brown | 12c green |
| 3c ultramarine | 30c deep carmine and ultramarine |
| 6c ultramarine | |

Printed from the original dies engraved by the National Bank Note Co.

15c brown and blue, picture framed
15c brown and blue, picture without frame

The Bureau was in possession of the original die of the frame of the framed picture variety of the 15c, and another die containing the complete impression of the unframed variety; from this latter die two transfers were made, from one of which the picture was cut away and from the other the frame. Two new dies were made from these transfers and the unframed variety proof printed from these new dies, while the frame of the framed variety was printed from the original die and the new die used for the picture.

24c green and purple

The original die of the frame of the 24c was in the possession of the Bureau and another die containing the complete design; a transfer was taken from this latter die, the frame cut away, and a new die of the picture made from the transfer. This new die in conjunction with the original frame die was used in printing the proof.

The new dies were made by the Bureau in 1903 for the special printing of die proofs issued in 1904 in albums.

90c deep bright carmine and black

The above proof is a Government imitation. The Bureau was in possession of a die of the 90c, engraved by the National Bank Note Company,

containing the complete design but with Trumbull's head of Washington instead of the head of Lincoln; a transfer was taken from this die, the head cut away, and a new die made of the frame only. A transfer was taken from the die of the 15c 1866, the frame cut away, leaving only the head of Lincoln, and a die of the head made from this transfer.

These two new dies were used to print the proof, and were made by the Bureau of Engraving and Printing in 1903 for the special printing of die proofs issued in 1904 in albums.

1870

1c very deep blue

A Government imitation, printed from a die engraved at the Bureau of Engraving and Printing in 1903 for the special printing of die proofs issued in 1904 in albums.

1873

2c brown

12c purple

30c black

3c green

15c orange-yellow

90c carmine

7c vermilion

24c bright purple

Printed from the original dies engraved by the National Bank Note Co. and later altered by the Continental Bank Note Co.

6c rose-carmine

10c deep yellow-brown

Printed by mistake from the dies engraved by the American Bank Note Co. in 1881.

1875

2c vermilion

Printed from the original die engraved by the National Bank Note Co. and later altered by the Continental Bank Note Co.

5c deep blue

Printed from the original die engraved by the Continental Bank Note Co.

1881

1c dark gray blue

Printed from the original die engraved by the National Bank Note Co. and later altered by the Continental Bank Note Co. and still later re-engraved by the American Bank Note Co.

1882

3c green

5c brown

6c dull red

10c deep gray-brown

Printed from the original dies engraved by the American Bank Note Co.

1883

2c red-brown

4c green

Printed from the original dies engraved by the American Bank Note Co.

1887-88

1c dull blue

3c vermilion

5c indigo

2c light green

4c bright carmine

Printed from the original dies engraved by the American Bank Note Co.

30c orange brown

90c bright purple

Printed from the original dies engraved by the National Bank Note Co. and altered by the Continental Bank Note Co.

1890

| | | |
|----------------|-----------------|----------------|
| 1c ultramarine | 4c black-brown | 8c puce |
| 2c carmine | 5c yellow-brown | 10c dark green |
| 3c purple | 6c dull lake | 15c indigo |

The above are all Government imitations, printed from dies made by the Bureau of Engraving and Printing in 1903 for the special printing of die proofs issued in 1904 in albums.

| | |
|---|----------------|
| 30c black | 90c red-orange |
| Printed from the original dies engraved by the American Bank Note Co. | |

1893

| | | |
|-----------------|------------------|-------------------|
| 1c deep blue | 8c magenta | \$1. vermilion |
| 2c purple lilac | 10c black-brown | \$2. claret |
| 3c green | 15c green | \$3. yellow-green |
| 4c dull blue | 30c orange-brown | \$4. rose-pink |
| 5c brown | 50c slate black | \$5. black |
| 6c red-lilac | | |

Printed from the original dies engraved by the American Bank Note Co.

1894

| | | |
|----------------|--------------------|------------|
| 1c bright blue | 5c light red-brown | 10c green |
| 3c deep violet | 6c dull lake | 15c indigo |
| 4c dark brown | 8c puce | |

Printed from the original dies engraved by the American Bank Note Company for the 1890 issue and altered by the Bureau of Engraving and Printing by the addition of triangles in the upper corners.

| | | |
|---------------------------|--------------------|-----------------|
| 2c rose-red, triangle III | \$1. black | \$5. dark green |
| 50c red-orange | \$2. sapphire blue | |

Printed from the original dies engraved by the Bureau of Engraving and Printing.

1898

2c scarlet, triangle III

Printed from the original die engraved by the Bureau of Engraving and Printing.

| | | |
|---------------|--------------|------------------|
| 1c green | 5c deep blue | 10c yellow-brown |
| 4c rose-brown | 6c claret | 15c olive |

Printed from the original dies engraved by the American Bank Note Company for the 1890 issue and altered by the Bureau of Engraving and Printing by the addition of triangles in the upper corners.

1898 OMAHA

| | | |
|-----------|----------------|-------------------|
| 1c green | 5c deep blue | 50c slate olive |
| 2c copper | 8c magenta | \$1. black |
| 4c orange | 10c gray lilac | \$2. orange-brown |

Printed from the original dies engraved by the Bureau of Engraving and Printing.

1901

| | |
|---------------------------|-------------------------------|
| 1c green and black | 5c deep ultramarine and black |
| 2c carmine and black | 8c magenta and black |
| 4c orange-brown and black | 10c yellow-brown and black |

Printed from the original dies engraved by the Bureau of Engraving and Printing.

1902

| | | |
|----------------|------------------|-----------------|
| 1c deep green | 6c purple lake | 50c orange |
| 2c carmine | 8c slate lilac | \$1. black |
| 3c deep violet | 10c yellow-brown | \$2. deep blue |
| 4c gray-brown | 13c purple black | \$5. dark green |
| 5c indigo | 15c olive | |

Printed from the original dies engraved by the Bureau of Engraving and Printing.

1903

2c carmine

Printed from the original die engraved by the Bureau of Engraving and Printing.

1904

| | | |
|------------|----------------|-------------------|
| 1c green | 3c deep violet | 10c reddish brown |
| 2c carmine | 5c deep blue | |

Printed from the original dies engraved by the Bureau of Engraving and Printing.

1907

| | | |
|----------|------------|--------------|
| 1c green | 2c carmine | 5c deep blue |
|----------|------------|--------------|

Printed from the original dies engraved by the Bureau of Engraving and Printing.

1908-09

| | | |
|----------------|--------------|-------------------|
| 1c green | 5c deep blue | 13c sea-green |
| 2c carmine | 6c orange | 15c ultramarine |
| 3c deep violet | 8c olive | 50c violet |
| 4c brown | 10c yellow | \$1. purple brown |

Printed from the original dies engraved by the Bureau of Engraving and Printing.

1909

2c carmine, Lincoln
2c carmine, Alaska-Yukon
2c carmine, Hudson-Fulton

Printed from the original dies engraved by the Bureau of Engraving and Printing.

1912

| | | |
|------------|-------------------|-------------------|
| 1c green | 10c orange-yellow | 50c lilac |
| 2c carmine | 15c gray | \$1. purple black |
| 8c olive | | |

Printed from the original dies engraved by the Bureau of Engraving and Printing.

1912-13—PANAMA-PACIFIC

| | | |
|------------|-------------------|----------------|
| 1c green | 5c deep blue | 10c red-orange |
| 2c carmine | 10c orange-yellow | |

Printed from the original dies engraved by the Bureau of Engraving and Printing.

1914

| | | |
|-----------|------------------|----------------|
| 7c black | 12c brown purple | 30c bright red |
| 9c salmon | 20c ultramarine | |

Printed from the original dies engraved by the Bureau of Engraving and Printing.

PARCEL POST—1912-13

| | | |
|------------|-------------|--------------|
| 1c carmine | 5c carmine | 25c carmine |
| 2c carmine | 10c carmine | 50c carmine |
| 3c carmine | 15c carmine | 75c carmine |
| 4c carmine | 20c carmine | \$1. carmine |

Printed from the original dies engraved by the Bureau of Engraving and Printing.

REGISTRATION STAMP

1911 10c ultramarine

Printed from the original die engraved by the Bureau of Engraving and Printing.

SPECIAL DELIVERY

1885 10c indigo

1888 10c indigo

1893 10c orange-yellow

Printed from the original dies engraved by the American Bank Note Co.

1894 10c indigo

1908 10c green

1911 10c bright ultramarine

1902 10c deep ultramarine

Printed from the original dies engraved by the Bureau of Engraving and Printing.

POSTAGE DUE

1879

1c yellow brown

5c yellow brown

30c yellow brown

2c yellow brown

10c yellow brown

50c yellow brown

3c yellow brown

Printed from the original dies engraved by the American Bank Note Co.

1889

1c red-brown

5c red-brown

30c red-brown

2c red-brown

10c red-brown

50c red-brown

3c red-brown

Printed from the original dies engraved by the American Bank Note Co.

1891-93

1c claret

5c claret

30c claret

2c claret

10c claret

50c claret

3c claret

Printed from the original dies engraved by the American Bank Note Co.

1894

1c deep claret

5c deep claret

30c deep claret

2c deep claret

10c deep claret

50c deep claret

3c deep claret

Printed from the original dies engraved by the Bureau of Engraving and Printing.

PARCEL POST DUE—1912-13

1c green

5c green

25c green

2c green

10c green

Printed from the original dies engraved by the Bureau of Engraving and Printing.

OFFICIAL STAMPS

AGRICULTURE DEPARTMENT, 1873

1c yellow

6c yellow

15c yellow

2c yellow

10c yellow

24c yellow

3c yellow

12c yellow

30c yellow

Printed from the original dies engraved by the Continental Bank Note Co.

EXECUTIVE DEPARTMENT, 1873

| | | |
|------------|------------|-------------|
| 1c carmine | 3c carmine | 10c carmine |
| 2c carmine | 6c carmine | |

Printed from the original dies engraved by the Continental Bank Note Co.

INTERIOR DEPARTMENT, 1873

| | | |
|--------------|---------------|---------------|
| 1c vermilion | 10c vermilion | 24c vermilion |
| 2c vermilion | 12c vermilion | 30c vermilion |
| 3c vermilion | 15c vermilion | 90c vermilion |
| 6c vermilion | | |

Printed from the original dies engraved by the Continental Bank Note Co.

DEPARTMENT OF JUSTICE, 1873

| | | |
|-----------|------------|------------|
| 1c purple | 10c purple | 24c purple |
| 2c purple | 12c purple | 30c purple |
| 3c purple | 15c purple | 90c purple |
| 6c purple | | |

Printed from the original dies engraved by the Continental Bank Note Co.

NAVY DEPARTMENT, 1873

| | | |
|----------------|-----------------|-----------------|
| 1c bright blue | 7c bright blue | 24c bright blue |
| 2c bright blue | 10c bright blue | 30c bright blue |
| 3c bright blue | 12c bright blue | 90c bright blue |
| 6c bright blue | 15c bright blue | |

Printed from the original dies engraved by the Continental Bank Note Co.

STATE DEPARTMENT, 1873

| | | |
|----------|-----------|---------------------|
| 1c green | 7c green | 24c green |
| 2c green | 10c green | 30c green |
| 3c green | 12c green | 90c green |
| 6c green | 15c green | \$2 green and black |

Printed from the original dies engraved by the Continental Bank Note Co.

\$5 green and black \$10 green and black \$20 green and black

The Bureau was in possession of the original dies for the head of Seward engraved by the Continental Bank Note Co., and the original die for the frame of the \$2; from this latter die, transfers were made, the value label cut away, and new dies made from them in that condition. The value labels for \$5, \$10, and \$20, were then engraved on the new dies and these new dies together with the original head die were used to print the \$5, \$10, and \$20.

TREASURY DEPARTMENT, 1873

| | | |
|----------------|-----------------|-----------------|
| 1c light brown | 7c light brown | 24c light brown |
| 2c light brown | 10c light brown | 30c light brown |
| 3c light brown | 12c light brown | 90c light brown |
| 6c light brown | 15c light brown | |

Printed from the original dies engraved by the Continental Bank Note Co.

WAR DEPARTMENT, 1873

| | | |
|---------------|----------------|----------------|
| 1c brown-rose | 7c brown-rose | 24c brown-rose |
| 2c brown-rose | 10c brown-rose | 30c brown-rose |
| 3c brown-rose | 12c brown-rose | 90c brown-rose |
| 6c brown-rose | 15c brown-rose | |

Printed from the original dies engraved by the Continental Bank Note Co.

POST OFFICE DEPARTMENT, 1873

| | | |
|----------|-----------|-----------|
| 1c black | 10c black | 24c black |
| 2c black | 12c black | 30c black |
| 3c black | 15c black | 90c black |
| 6c black | | |

Printed from the original dies engraved by the Continental Bank Note Co.

POSTAL SAVINGS—OFFICIAL MAIL, 1911

| | | |
|-----------|-----------|-----------------|
| 1c purple | 10c red | \$1 ultramarine |
| 2c black | 50c green | |

Printed from the original dies engraved by the Bureau of Engraving and Printing.

POSTAL SAVINGS, 1911

| | |
|------------|---------------|
| 10c orange | 10c deep blue |
|------------|---------------|

Printed from the original dies engraved by the Bureau of Engraving and Printing.

NEWSPAPER STAMPS, 1865

| | | |
|---------------|-----------|---------------|
| 5c light blue | 10c green | 25c vermilion |
|---------------|-----------|---------------|

Printed from typographs made by the National Bank Note Company.

1875

| | | |
|--------------|--------------|-------------------|
| 2c black | 24c rose-red | \$3 vermilion |
| 3c black | 36c rose-red | \$6 ultramarine |
| 4c black | 48c rose-red | \$9 yellow buff |
| 6c black | 60c rose-red | \$12 green |
| 8c black | 72c rose-red | \$24 purple black |
| 9c black | 84c rose-red | \$36 brown-rose |
| 10c black | 96c rose-red | \$48 yellow-brown |
| 12c rose-red | \$1.92 brown | \$60 purple |

Printed from the original dies engraved by the Continental Bank Note Co.

1885

| | | |
|---------------|---------------|---------------|
| 12c rose-pink | 48c rose-pink | 84c rose-pink |
| 24c rose-pink | 60c rose-pink | 96c rose-pink |
| 36c rose-pink | 72c rose-pink | |

Printed from the original dies engraved by the Continental Bank Note Co.

1c black

Printed from the original die engraved by the American Bank Note Co.

1894

| | | |
|-----------|------------------|-------------------|
| 1c black | 25c deep carmine | \$10 green |
| 2c black | 50c deep carmine | \$20 purple black |
| 5c black | \$2 vermilion | \$50 lake |
| 10c black | \$5 bright blue | \$100 purple |

Printed from the original dies engraved by the Bureau of Engraving and Printing.

PHILIPPINES, 1906

| | | |
|-----------------|-----------------------|------------------|
| 2c deep green | 12c deep lake | 1p yellow orange |
| 4c deep carmine | 16c purple black | 2p black |
| 6c purple | 20c deep yellow brown | 4p indigo |
| 8c brown | 26c dark purple brown | 10p green |
| 10c dark blue | 30c olive | |

Printed from the original dies engraved by the Bureau of Engraving and Printing.

1909-13

| | | |
|------------------|-----------------|----------------------|
| 12c orange | 26c sea green | 1p lilac |
| 16c yellow olive | 30c ultramarine | 2p deep purple brown |
| 20c deep yellow | | |

Printed from the original dies engraved by the Bureau of Engraving and Printing.

1915

30c gray
Printed from the original die engraved by the Bureau of Engraving and Printing.

SPECIAL DELIVERY, 1906

20c deep blue
Printed from the original die engraved by the Bureau of Engraving and Printing.

THE POSTAL ISSUES OF AUSTRIA.

BY J. BRACE CHITTENDEN, Ph. D.

(Continued).

EIGHTH ISSUE.



III. 88.



III. 89.

From Sept. 1st, 1890 until Sept. 1st, 1891 (20, 24, 30, 50kr.)
From Sept. 1st, 1890 until Sept. 30, 1900, (1, 2, 3, 5, 10, 12, 15 Kr.).
From Sept. 1st, 1890 until Feb. 1st, 1896, (1, 2 G.).

The Kreuzer values have the bust of the Emperor to left with wreath on a ground of horizontal lines, surrounded by a double oval frame containing the inscription "Kais. Konigl. Oesterr. Post." The frame is broken at the four corners by circles within which values are printed in figures in black. Printed until 1896 on hard glass-like granite paper and thereafter on soft thin granite paper; no watermark; perfs. from 9 to 13½. The 1G and 2G are similar but larger vertically and the figures in the circles are white on a colored ground.

TABLE 24.

1890-1896.

| Variety | A. p. 10, 10½ or 11½ | | B. p. 9¼ | | C. p.11 | | D. p.12½, 13:12½ or 13:13½. | | E. p.1 |
|-----------------------|-------------------------|-----|-----------|------|-----------|------|-----------------------------------|------|----------|
| | 1st or 2d paper | | 1st paper | | 1st paper | | 2d paper | | 2d paper |
| 40 1K. black | | | | | | | | | |
| a 1K. gray black | .01 | .01 | 6.25 | .10 | — | .50 | .04 | .01 | — |
| b 1K. gray | | | | | | | | | |
| 41 2K. dark brown | | | | | | | | | |
| a 2K. light brown | .02 | .01 | 11.25 | 1.50 | — | .25 | .05 | .01 | — |
| b 2K. reddish brown | | | | | | | | | |
| 42 3K. gray green | | | | | | | | | |
| a 3K. yellow green | .02 | .01 | 8.75 | .12 | 3.00 | .20 | .08 | .01 | — |
| b 3K. blue green | | | | | | | | | |
| 43 5K. carmine rose | | | | | | | | | |
| a 5K. rose | .04 | .01 | 7.50 | .12 | 4.50 | .08 | .03 | .01 | — |
| b 5K. pale rose | | | | | | | | | |
| c 5K. rose on rose | | | — | — | | | | | |
| 44 10K. light blue | | | | | | | | | |
| a 10K. dull blue | | | | | | | | | |
| b 10K. cobalt blue | .05 | .01 | 15.00 | 1.50 | — | .38 | .10 | .01 | — |
| c 10K. ultramarine | | | | | | | | | |
| 45 12K. brown rose | | | | | | | | | |
| a 12K. light bwn rose | .08 | .02 | 7.50 | .08 | — | .75 | .20 | .04 | — |
| 46 15K. brown violet | | | | | | | | | |
| a 15K. light bwn " | .09 | .01 | 11.25 | .12 | — | .25 | .12 | .01 | — |
| 47 20K. olive green | | | | | | | | | |
| a 20K. dark green | .12 | .06 | 10.00 | .18 | — | 1.00 | D. p. 12½ 1st paper | | |
| 48 24K. steel blue | | | | | | | | | |
| a 24K. gray blue | .15 | .05 | 8.75 | .10 | — | — | | | |
| 49 30K. dark brown | | | | | | | | | |
| a 30K. gray brown | .18 | .01 | 5.00 | .06 | — | 1.00 | — | 2.00 | |
| 50 50K. blue violet | | | | | | | | | |
| a 50K. red violet | .30 | .18 | 10.00 | .38 | — | — | | | |
| b 50K. blue lilac | | | | | | | | | |
| 51 1G. dark blue | | | | | | | | | |
| a 1G. bright blue | .62 | .05 | 20.00 | .25 | — | 1.00 | .80 | .05 | |
| 52 2G. dark carmine | | | | | | | | | |
| a 2G. pale carmine | 1.25 | .50 | 3.75 | .62 | — | — | 1.65 | .50 | |

NOTE 1. It will be noted that A. calls for 6 sets, perforation 10, 10½ and 11½, the prices given being for both hard and soft paper. B. and C. for one each occurring on hard paper only. The 20, 24, 30 and 50K. in this type went out of use in 1891, and therefore never appear on the first paper perforated 13:12½, or 13:13½ which are not compound perforations in the true sense but regular after this date. Moreover these values are always on the hard paper, ordinarily perforated as in A. and the same is true of the 1G. and 2G. Perforations 9¼, 9¾, 12, 12½, 13, 13½ come only on the old hard paper. The prices quoted for these rarer perforations on hard paper complete the foregoing table as follows:

TABLE 25.

Rare perforations on 1st paper, priced used. (1890-98) Nos. 40-52.

| Perfs. | Kreuzer. | | | | | | | | | | Gulden | | |
|--------|----------|------|-----|-----|------|------|------|----|----|------|--------|-----|-----|
| | 1 | 2 | 3 | 5 | 10 | 12 | 15 | 20 | 24 | 30 | 50 | 1 | 2 |
| 9¼ | .75 | 1.50 | .75 | .50 | 1.25 | 1.00 | 1.25 | — | — | 1.00 | — | — | — |
| 12 | — | .75 | .50 | .25 | — | — | — | — | — | 2.50 | — | .35 | — |
| 12½ | .62 | .50 | .38 | .12 | 1.00 | — | — | — | — | 2.00 | — | .05 | .35 |
| 13 | — | 1.00 | .75 | .38 | — | — | — | — | — | — | — | .25 | .75 |
| 13½ | .75 | .50 | .25 | .12 | .15 | — | .25 | — | — | — | — | — | — |

NOTE 2. The foregoing tables suffice to give a line on the comparative values of the ordinary standard perforations, but we still have the compound and mixed perforations to consider. The student is again referred to Note 1, Seventh Issue, 1883-91, on Austrian Perforations, to understand what is meant by the statement that up to 1896 we still find three regular machines running perforation 10 and no less than 9 line perforating machines to help out, affording 10 ordinary varieties on the hard paper to which must be added the work on the soft paper done by the new complete perforating machines that ran 13:12½ and 13:13½. These last are not, therefore, compound perforations but regular. The possibilities for compound perforations are quite sufficient without these; no less than the permutations of the 9 line machines taken two at a time which is little less than appalling. Kohl rightly neglects all showing but ½ as a difference and finds the following to be the existing varieties.

TABLE 26.

Perforation table, Issue of 1890-1896.

First group, ordinary (priced before). Second group, compound.

| | Kreuzer | | | | | | | | | | Gulden | | Paper | |
|-----------|---------|------|------|------|------|------|------|------|------|------|--------|------|-------|-----------|
| | 1 | 2 | 3 | 5 | 10 | 12 | 15 | 20 | 24 | 30 | 50 | 1 | | 2 |
| (Reg.) | 1 | 2 | 3 | 5 | 10 | 12 | 15 | 20 | 24 | 30 | 50 | | | 1st or 2d |
| 2½ (Reg.) | 1 | 2 | 3 | 5 | 10 | 12 | 15 | — | — | — | — | | | 2d |
| 3½ (Reg.) | 1 | 2 | 3 | 5 | 10 | 12 | 15 | — | — | — | — | | | 2d |
| | 1 | 2 | 3 | 5 | 10 | 12 | 15 | 20 | 24 | 30 | 50 | 1 | 2 | 1st |
| | 1 | 2 | 3 | 5 | 10 | 12 | 15 | — | — | 30 | — | — | — | 1st |
| | 1 | 2 | 3 | 5 | 10 | 12 | 15 | 20 | 24 | 30 | 50 | 1 | 2 | 1st & 2d |
| | 1 | 2 | 3 | 5 | 10 | 12 | 15 | 20 | — | 30 | — | 1 | — | 1st |
| | 1 | 2 | 3 | 5 | 10 | 12 | 15 | 20 | 24 | 30 | 50 | 1 | 2 | 1st & 2d |
| | — | 2 | 3 | 5 | — | — | — | — | — | 30 | — | 1 | — | 1st |
| | 1 | 2 | 3 | 5 | 10 | 12 | 15 | — | — | 30 | — | 1 | 2 | 1st or 2d |
| | — | 2 | 3 | 5 | — | — | — | — | — | — | — | 1 | 2 | 1st |
| | 1 | 2 | 3 | 5 | 10 | 12 | 15 | — | — | — | — | — | — | 1st or 2d |
| 0 ½ | 3.75 | — | — | 2.00 | — | — | — | — | 6.25 | — | — | — | — | — |
| 1 ½ | 3.75 | — | — | 2.00 | — | — | 7.50 | — | 6.25 | 3.75 | — | — | — | — |
| 2 ½ | — | — | — | — | — | 2.00 | — | — | — | — | — | — | — | — |
| 0 ½ | 5.00 | — | — | — | — | — | — | — | — | — | — | — | — | — |
| 1 | — | — | — | — | — | — | — | — | — | — | — | — | — | — |
| 1 ½ | 5.00 | — | — | — | 6.25 | 2.00 | — | — | — | 7.50 | — | — | — | — |
| 9 ¼ | — | — | — | — | — | — | — | — | — | 3.75 | — | — | — | — |
| 1 ½ | — | — | — | — | — | — | — | — | — | — | — | — | — | — |
| 9 ¼ | 2.00 | 1.25 | 2.50 | .50 | 3.00 | 1.50 | 2.00 | 3.00 | 1.25 | 1.50 | 3.75 | 2.50 | 7.50 | — |
| 1 ½ | 1.00 | .75 | .50 | .75 | .50 | 1.00 | 1.00 | — | 3.75 | — | — | — | — | — |
| 2 ½ | — | — | 2.00 | 1.00 | 5.00 | 7.50 | — | — | — | — | — | — | — | — |
| 3 ½ | — | — | — | 3.00 | — | — | — | — | — | — | — | — | — | — |
| 9 ¾ | — | — | — | — | — | — | — | — | — | — | — | — | — | — |
| 3 | — | — | — | — | — | — | — | — | — | — | — | — | — | 3.75 |
| 9 ¼ | — | — | — | — | — | — | — | 7.50 | 2.50 | 3.75 | — | — | — | — |
| 9 ¾ | — | — | 5.00 | — | — | — | — | — | 7.50 | — | — | — | — | — |
| 0 ½ | 3.75 | 1.50 | .75 | .25 | .75 | 2.00 | 1.25 | 3.75 | 3.75 | 2.50 | — | 1.25 | 7.50 | — |
| 2 ½ | — | — | 1.00 | .50 | 1.00 | — | 1.50 | 3.75 | — | — | — | — | — | — |
| 3 ½ | — | 2.50 | .75 | .50 | — | — | — | — | — | — | — | — | — | — |
| 3 | — | — | 1.00 | — | — | — | — | — | — | — | — | — | — | — |
| 0 ½ | 1.00 | .75 | .50 | .50 | .75 | 2.00 | 1.50 | — | — | 2.50 | — | — | — | — |
| 1 ½ | — | — | — | .50 | — | 2.50 | — | 3.75 | — | — | — | — | — | — |
| 1 ½ | — | — | — | — | — | — | — | — | — | — | — | 3.75 | — | — |
| 2 | — | — | — | — | — | — | — | — | — | — | — | .50 | 1.00 | — |
| 0 ½ | — | 3.00 | 2.00 | 1.50 | 5.00 | — | 1.50 | — | — | — | — | — | — | — |
| 1 ½ | — | 3.00 | 2.00 | 1.00 | — | — | — | — | — | — | — | — | — | — |

NOTE 3. The foregoing compounds as given by Kohl serve the purpose of giving a line on values but as a table it is not very satisfactory especially in the large perforations. In general, variations of only $\frac{1}{2}$ are neglected and only the compounds of the primary varieties above are listed.

- A. Anything under $9\frac{1}{4}$ includes 9 and $9:9\frac{1}{4}$ etc.
- B. $9\frac{3}{4}$ up to 10 (line perforation).
- C. Perforation 10 is usually $10\frac{1}{4}$ (regular).
- D. Perforation 11 or towards $10\frac{3}{4}$. Those nearing $11\frac{1}{4}$ belong to $11\frac{1}{2}$.
- E. Perforation 13 (mostly $12\frac{3}{4}$).
- F. Perforation $13\frac{1}{2}$ ($13\frac{1}{4}$ - $13\frac{1}{2}$).
- G. Perforation 10 may be regular or line (mostly regular).
- H. Perforation $13:12\frac{1}{2}$ and $13:13\frac{1}{2}$ (regular and not compound).

Probably the above tabulation is the best, conforming to that adopted in the preceding issue, and will be found to include the few cases of mixed perforations that arise. Taking it all in all, a collection of this issue according to perforations is the hardest test of patience and perseverance in this line to be found in Philately.

The collector will need the following sets.

- A. Perf $9\frac{1}{4}$ (9) 1st paper, scarce, especially unused, all values.
- B. Perf 10, ($9\frac{3}{4}$) 1st paper, scarce (1, 2, 3, 5, 10, 12, 15, 30K.).
- C. Perf. 10, ($10\frac{1}{4}$) (Reg.) 1st or 2nd papers, all values, common.
- D. Perf. $10\frac{1}{2}$, (Reg.), 1st or 2nd papers, all values, common.
- E. Perf. 11, ($10\frac{3}{4}$) 1st paper, all values, 24K. and 2G. (rarities).
- F. Perf. $11\frac{1}{2}$, 1st or 2nd paper, all values, common.
- G. Perf. 12, 1st paper, scarce (2, 3, 5, 30K., 1G.).
- H. Perf. $12\frac{1}{2}$, 1st paper, scarce, (1, 2, 3, 5, 10, 30K., 1G., 2G.).
2nd paper, common (1 to 15K.).
- I. Perf. 13 ($12\frac{3}{4}$) 1st paper, scarce (2, 3, 5K., 1 and 2G.).
- J. Perf. $13\frac{1}{2}$, 1st paper, scarce, (1, 2, 3, 5, 10, 15K.)
2nd paper, ordinary, (1 to 15K.).

Compound perforations.

- K. Perf. $10\frac{1}{2}:11\frac{1}{2}$, very scarce, all values.
- L. Perf. $10\frac{1}{2}:12\frac{1}{2}$, scarce (1 to 15K. and 30K.).
- M. Perf. $11\frac{1}{2}:10\frac{1}{2}$, very scarce (all but 50K.).
- N. Perf. $12\frac{1}{2}:10\frac{1}{2}$, scarce (1 to 15K. and 30K.).
- O. Other compound perforations and mixed perforations.
(To be continued.)

NEW ISSUE NOTES.

We are indebted to Mr. J. B. Leavy for the copies of the circulars sent out by the Director of the Universal Postal Union under dates of April 14 and May 7, announcing the March and April distributions, which we print herewith.

APRIL 14, 1915.

1st. **Australian Confederation**; Postage stamp of 4 pence;

2nd. **Cuba**: Postage stamps of 1, 2, 3, 5, 5, 8, 10, 10, 50 centavos and 1 peso, and postage due stamps of 1, 2, and 5 centavos (these values have been in use since the 24th of February last);

3rd. **Dominican Republic**: Official stamps of 1, 2, 5, 10 and 20 centavos bearing the surcharge "Habilitado 1915" and of 20 centavos bearing the surcharge "Habilitado 1915 Medio centavo" (these values are to be employed in the prepayment of ordinary correspondence; all the ancient values are to be discontinued, with the exception of the official stamps);

4th. **Panama**: Postage stamps of $\frac{1}{2}$, 1, 2, $2\frac{1}{2}$, 3, 5, 10 and 20 centesimos (these values were put in circulation on the 1st of March last; the ancient values are to be continued in use);

5th. **Persia:** Postage stamp of 12 on 13 chahis;

6th. **Portuguese Colonies.**

(a) **Angola:** Postage stamps of 10 and 200 reis with the portrait of Dom Louis, bearing in red the surcharged word "Republica", and surcharged in black with "115 reis"; of 100 reis with the portrait of Dom Louis, bearing in red the surcharged word "Republica", and surcharged in black with "130 reis"; of 80, 100 and 150 reis with portrait of Dom Carlos (1st issue), bearing in red the surcharged word "Republica", and surcharged in black with "115"; of 15, 75 and 300 reis with the portrait of Dom Carlos (1st issue), bearing in red the surcharged word "Republica", and surcharged in black with "130 reis";

(b) **Cape Verde:** Postage stamps of 10 and 20 reis with the portrait of Dom Louis, bearing in red the surcharged word "Republica", and surcharged in black with "115 reis"; of 50 and 100 reis with the portrait of Dom Louis bearing in red the surcharged word "Republica", and surcharged in black with "130 reis"; of 5, 25 and 150 reis with the portrait of Dom Carlos (1st issue), bearing in red the surcharged word "Republica", and surcharged in black with "115 reis"; of 75, 80 and 200 reis with the portrait of Dom Carlos (1st issue), bearing in red the surcharged word "Republica", and surcharged in black with "130 reis";

(c) **Congo:** 2½ reis of the 1st issue of Dom Carlos bearing in red the surcharged word "Republica", and surcharged in black with "115 reis"; 10 and 20 reis with the portrait of Dom Carlos (1st issue), bearing in red the surcharged word "Republica", and surcharged in black with "115 reis"; 5, 75 and 100 reis with the portrait of Dom Carlos (1st issue), bearing in red the surcharged word "Republica", and surcharged in black with "130 reis"; 15 and 50 reis with the portrait of Dom Carlos (2nd issue), bearing in red the surcharged word "Republica", and surcharged in black with "Provisorio"; 65 reis with the portrait of Dom Carlos (2nd issue), bearing in red the surcharged word "Republica", and surcharged in black with "50 reis"; the numerals "65" being obliterated with a bar;

(d) **Guinea:** Postage stamps of 40 and 50 reis with the portrait of Dom Louis, bearing in red the surcharged word "Republica", and surcharged in black with "115 reis"; 80 and 100 reis with the portrait of Dom Louis, bearing in red the surcharged word "Republica", and surcharged in black with "130 reis"; 2½ reis of the 1st issue of Dom Carlos, bearing in red the surcharged word "Republica", and surcharged in black with "115 reis"; 5 and 25 reis with the portrait of Dom Carlos (1st issue), bearing in red the surcharged word "Republica", and surcharged in black with "115 reis"; 150, 200 and 300 reis with the portrait of Dom Carlos (1st issue), bearing in red the surcharged word "Republica" and surcharged in black with "130 reis"; 15 and 50 reis with the portrait of Dom Carlos (2nd issue), bearing in red the surcharged word "Republica", and surcharged in black with "Provisorio"; 65 reis with the portrait of Dom Carlos (2nd issue), bearing in red the surcharged word "Republica", and surcharged in black with "50 reis"; the numerals "65" being obliterated by a bar;

(e) **Inhambane:** 65 reis with the portrait of Dom Carlos (2nd issue), bearing in red the surcharged word "Republica", and surcharged in black with "50 reis"; the numerals "65" being obliterated by a bar;

(f) **Lourenço Marques:** Postage stamps of 10, 200 and 300 reis with the portrait of Dom Carlos (1st issue), bearing in red the surcharged word "Republica", and surcharged in black with "115 reis"; of 150 reis with the portrait of Dom Carlos (1st issue), bearing in red the surcharged word "Republica", and surcharged in black with "130 reis";

(g) **Mozambique:** 2½ reis of the 1st issue of Dom Carlos bearing in red the surcharged word "Republica", and surcharged in black with "115 reis"; 5 and 25 reis with the portrait of Dom Carlos (1st issue), bearing in red the surcharged word "Republica", and surcharged in black with "115 reis"; 75, 150 and 200 reis with the portrait of Dom Carlos (1st issue), bearing in red the surcharged word "Republica", and surcharged in black with "130 reis"; 65 reis with the portrait of Dom Carlos (2nd issue), bearing in red the surcharged word "Republica", and surcharged in black with "50 reis"; the numerals "65" being obliterated by a bar; 50 reis with the portrait of Dom Carlos (2nd issue), bearing in red the surcharged word "Republica", and surcharged in black with "Provisorio";

7th. **Roumania:** Postage stamp of 10 bani bearing the surcharge in black "Timbru de ajutor".

I have the honor to make known to you that the Office of the United States of America has expressed to me the desire to receive hereafter 6 specimens in lieu of 9 as heretofore of the postage stamps etc. distributed by the International Bureau.

I shall in consequence be very much obliged if you will do me the favor to forward 373 specimens in lieu of 376.

NOTE: The Cuba stamps are those in current use; the duplicate 5c is the commemorative stamp and one of the 10c is the special delivery. The Persia is surcharged on the 13ch. of 1909.

MAY 7, 1915.

1st. **Commonwealth of Australia:** Postage stamps of $\frac{1}{2}$ penny and 5 pence;

2nd. **Denmark:** Newspaper stamps of 8, 29 and 41 ore and postage stamps of 5, 10, 15, 20, 25, 40 and 50 bit for use in the Danish West Indies;

3d. **French Colonies:** Postage stamps of 10+5 centimes of the Red-cross, for use of the Ivory Coast, of Dahomey, of French Guinea, of Upper Senegal and Niger, of Indo China, of Madagascar, of Mauritania and of Senegal (total: 8 kinds);

4th. **Great Britain.**

Gold Coast: Postage stamp of 3 pence;

Grenada: Postage stamp of 1 shilling;

Kelantan: Postage stamp of 1 dollar;

5th. **Netherlands. Surinam:** Postage due of 10 cent printed in dissoluble color;

6th. **Persia:** Postage stamp of 5 chahis on 1 kran;

7th. **Portugal:** Postage due of $\frac{1}{2}$, 1 centavo, 2, 3, 4, 5 and 10 centavos (the postage due actually in use will continue to be of service until they are exhausted);

8th. **Portuguese Colonies. Lourenzo Marques:** Postage stamp of 5 reis with the portrait of Dom Carlos (2nd issue), divided diagonally in two parts by one perforation, bearing in red surcharge the word "Republica" and, on each half, the mention " $\frac{1}{4}$ "; postage stamp of $\frac{1}{2}$ centavo with the portrait of the Republic, divided diagonally in two parts by one perforation and bearing in red surcharge, on each half, the mention " $\frac{1}{4}$ ".

NOTE: The Australian Commonwealth appears to be typographed the same type as the 1 penny engraved 1913. They are watermarked crown and single line A and perforated 14. This also applies to the 4 pence noted in the last Berne circular.

The Danish West Indies are of the same type and colors as the 1908 but have the head of the current Denmark.

The Denmark newspaper stamps are the same type as the current; the colors are as follows: 8 ore green, 29 ore orange, 41 ore brown; these are exactly the colors of the 20, 38 and 68 ore respectively, which would indicate the discontinuance of these latter values.

The Gold Coast and Grenada are on paper colored through.

The Kelantan is same type as 1911 but the squares in the lower corners containing the value are brown.

The Persia is surcharged on the 1 kran of 1909.

The Portugal postage due are of the same type as 1904; the colors are the same in the same order for the values. They are not overprinted Republica.

UNITED STATES LOCAL STAMPS.

A Concise History and Memoranda.

COMPILED BY HENRY C. NEEDHAM.

(Continued.)

ADAMS' CITY EXPRESS POST

CITY EXPRESS POST

New York.

We are unable to supply authentic facts or information as to this Post. The stamps are found on various covers, the enclosures coming from sundry different places and bearing various dates. It is quite probable that the stamp was issued by Adams & Company of the Atlantic, as distinguished from Adams & Company of the Pacific, or California. We have noted the stamps on covers not only from New York City but from Boston and Philadelphia.

Adams & Company did business in these and many other cities as early as the fall of 1840; at this time under the name of Burke & Company. On or about July 1st, 1854, the concern took in the old firms of Harnden & Co., Thompson & Co., Kingsley & Co., and perhaps others under the name of Adams' Express Company.

We are in the dark as to the stamps here noted as Types III and IV, that is the stamps with the name of Adams on the left side erased and a scroll substituted. It is quite possible that the name Adams was substituted for the scroll, for we have no satisfactory information as to the date of issue. We have, however, seen the stamps on covers from Boston, and cancelled with the U. S. Mail Postmark. Others we have seen on covers bearing the usual New York cancellation of the early fifties.

It is useless to draw conclusions from all covers we have seen bearing stamps of this Post, for the reason that in no instance have we seen a satisfactory cancellation covering the stamp or showing its place of origin.

There are many apparent reprints and some counterfeits of the stamps of Types III and IV. These are almost always found on white wove paper of a medium thick texture, sometimes on a yellowish white, and occasionally on a pelure, but we have never noted either a reprint or a counterfeit on the paper of the color and texture of the accepted originals.

For reference we note that Types III and IV have been seen on covers with the U. S. Express Mail cancellation as early, in the case of the two-cent, as 1846, and of the 1 cent, as early as 1849. These covers, however, do not satisfactorily authenticate the issue or date of use.



Type I



Type II



Type III



Type IV

- | | |
|---------------------|--------------------|
| | Type I. 1850. |
| 2c Buff paper. | Type II. 1851-2. |
| 1c Buff paper. | Type III. No year. |
| 1c Gray blue paper. | Type IV. No year. |
| 2c Gray blue paper. | |

NEW SOUTH WALES.

Mistake in the Plating of the Two-Pence, Laureate, Plate I.

When I wrote the little article for your valued publication about the mistake in the plating of the two-pence, Laureate, Plate II, stars in corners (New South Wales), as shown on the illustration in Mr. Bassett Hull's book, published under the auspices of the Royal Philatelic Society, London, a part of my collection of the stamps of New South Wales was away from home, but I now have it here at the house and I find also the proof in the collection of the discovery of the mistake of the two-pence, Laureate, Plate I.

You may possibly be interested in knowing that in my collection I have two pairs of the two-pence, Plate I, both of which pairs consist of Nos. 33 and 34 in the plate. The No. 33 in both of these pairs is identically like No. 33 on the plate of the two-pence, Plate I, in Mr. Bassett Hull's book, but the No. 34 is not like the No. 34 on the plate in the book; and in fact, this stamp does not appear anywhere in the reconstructed plate. The stamp shown on the illustration of the reconstructed plate of the two-pence, Plate I, is a duplicate of No. 32 on the plate. It was the possession of these two pairs, 33-34, which caused me to reconstruct my Plate I of the two-pence correctly in the first place.

Curiously enough I did not realize that my plate differed from the illustration in Mr. Bassett Hull's book until sometime after the plating had been correctly completed and mounted in the album. I have more than one complete reconstructed plate of the two-pence, Plate I, and as I possess a large number of pairs and strips and blocks of these stamps it was possible by using them, not only to complete the plating, to a considerable extent, but to demonstrate it.

In this interesting philatelic work I have had the cooperation of my friend, Mr. Louis G. Barrett, of the Boston Philatelic Society. I am, of course, pleased that number 34 in Plate I was correctly placed in our plating the year before the corrected illustration was received from London, and that I have proof of it in my album.

CHARLES LATHROP PACK.

HISTORICAL DISCOVERY OF THE DATE OF ISSUE OF UNITED STATES STAMPED ENVELOPES.

BY VICTOR M. BERTHOLD.

Readers of THE PHILATELIC GAZETTE may recall a short notice which appeared June 14th, Vol. IV, No. 6, announcing that in accordance with a search in the departmental files of the Post Office in Washington, the date of issue of United States stamped envelopes should be changed from July or August to June 1853. The official information did not, however, indicate the exact date when stamped envelopes were first sold to the public. A recent important find of a carefully kept commercial correspondence, filing the letter in the original envelope, has furnished us at last the means of settling this most interesting point beyond the shadow of a doubt.

Up to the present, or 61 years after the issue of stamped United States envelopes, all philatelic writers and collectors have erroneously assumed that United States stamped envelopes were issued to the public for the first time in July 1853. On this point a brief review of the foremost philatelic publications is of interest.

Dr. Gilbert Harrison, in his famous publication on Nesbitt envelopes, writes, "Stamped envelopes were introduced in the United States in July 1853", and in a subsequent list of the first dies and sizes of envelopes states:

Date of issue of 3c. Note size. Dies A, B, and D. September 1853.
Date of issue of 3c. Letter size. Dies A, B, C, and D. July 1853.

For the benefit of philatelists not versed in this branch, the explanation of the letters A, B, C, D, is given:

- A. 2c. red, 1853. Short label with narrow curved ends.
- B. 2c. red, 1853. Short label with square ends.
- C. 2c. red, 1853. Short label with diagonal lines at ends (K-Die).
- D. 2c. red, 1853. Long label with square ends.

In the U. S. Stamped Envelope Catalogue published in 1892 by Messrs. Tiffany, Bogert and Rechert, the date of issue of all these dies is merely 1853.

Dr. W. E. V. Horner, in both his first and last editions, gives Aug. 4, 1853 as the first date of issue of Die A.

Official sources supply the following information which is quoted here for the purpose of giving the reader an exhaustive knowledge of the subject.

1) The Annual Report of the Postmaster-General, dated December 4, 1852, states:

“Such envelopes as are authorized by the above law (Act of the Thirty-Second Congress, Stat. I, Chap. 113, Sec. 8—approved, Aug. 31, 1852) are now in preparation, and will soon be issued.”

2) Next we find a paragraph in the Scientific American of Feb. 5, 1853, i. e.

“G. F. Nesbitt has shown to the Postmaster-General an embossed stamp for prepaid envelopes which has been accepted and the manufacture will at once proceed. Such, however, is the labor and care required for their production that none will be ready for delivery before the middle of next April.”

By far the most exhaustive information concerning the issue of stamped U. S. envelopes is contained in Vol. 1, page 66, of the American Journal of Philately, April 1888, from which the following paragraphs are taken:

“The Act to establish Post Roads and for other purposes was approved August 31, 1852. This Act provided that the Postmaster General shall be, and he is hereby authorized to provide and furnish to all Postmasters and other persons applying and paying therefor, suitable letter envelopes * * * * * with such watermarks (note the plural) as he may deem expedient, and with one or more Postage Stamps with such device and of such denomination and value as he may direct, printed or impressed thereon * * * * * and the date of such letter, or of the receipt or transmission thereof, to be written or stamped or otherwise to appear on such envelope.”

The writer in the American Journal of Philately then continues to say:

“The envelopes authorized by the above Act were not issued to the public until a year later (i. e. August 1853) as will be seen by the annexed Circular sent to the various Postmasters, and it is not certain that they were ready at the date given. The date of this Circular is June 15, 1853, and is signed by James Campbell, Postmaster General.”

In other words, the writer contends that because the Circular of the Postmaster General bears date of June 15, 1853, no U. S. stamped envelopes could possibly have been issued to the Public prior thereto, and it was generally assumed that the first envelope issue took place in July 1853.

That United States envelopes were in the hands of the public early in July 1853 is proven by a paragraph which appeared in the New York Times of July 6, 1853, objecting to the use of the Nesbitt seal or “tress” on the flap of the envelope and informing the public that after this date the use of the seal would be abolished.

Yet more to the point is a line in the National Intelligencer of Washington, D. C. of July 7, 1853, describing the envelopes “just sent out for distribution”.

Boston June 16th 1853

Mr Chaffee

Dear Sir

We are in want
of another lot of sticky Trust
immediately -

Please send us 25 Black
as soon as you can possibly
do so -

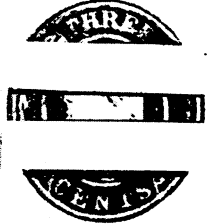
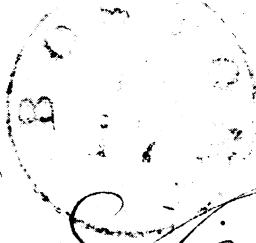

Mr O. S. Chaffee
Mansfield
Centre
Conn.

Considering all the above mentioned items it is not to be wondered at that up to the present the date of issue of U. S. stamped envelopes has been assumed to be **July 1853**.—In this connection it is rather a surprising fact to find that the stamped envelopes were distributed to and used by the public in Boston a month prior to the last mentioned news paragraph of the National Intelligencer. Such, however, is the indisputable evidence which is now published for the first time.

The irrefutable fact is that we have found in the correspondence mentioned in the introductory paragraph of this paper a buff envelope, bearing Die A, plainly stamped in red ink "BOSTON JUN 17." It contains the original letter, dated June 16, 1853. In other words, this envelope must have been bought at least a day prior to the outside date stamp, and probably was bought June 15, 1853.

From the above we may deduce:

- 1) That the date of issue of U. S. stamped envelopes to the public was June 15, 1853
- 2) That this envelope, considered from the historical-philatelic point, is unique and of great value, being one of the U. S. envelopes sold the first day of issue to the public.
- 3) That practically this envelope has a good claim to be considered the first U. S. stamped envelope used by the public.

It will certainly interest the envelope collector to hear that this buff envelope does not bear a Nesbitt tress on the point of the flap.

Subjoined is a list of the envelopes found containing the original enclosures and the date of each letter.

YEAR 1853. 3c. DIE A.

| | Date | Paper | Type | Head | Tress | Post Office |
|-----|---------|-------|------|------|---------|-------------------|
| 1. | June 16 | Buff | 10 | VIII | no seal | Boston |
| 2. | July 22 | White | 4 | II | seal | New Haven |
| 3. | July 30 | Buff | 6 | IV | seal | Philadelphia |
| 4. | Aug. 1 | White | 12 | X | no seal | New York |
| 5. | Aug. 8 | White | 7 | V | no seal | Providence, R. I. |
| 6. | Sep. 6 | White | 12 | X | no seal | New York |
| 7. | Nov. 9 | Buff | 11 | IX | seal | Providence, R. I. |
| 8. | Nov. 10 | White | 4 | II | no seal | Philadelphia |
| 9. | Dec. 1 | Buff | 6 | IV | no seal | New York |
| 10. | Dec. 29 | Buff | 7 | V | no seal | New York |

The above list shows that of the identified 10 envelopes only 3 have the seal or tress, also that of the 12 types of Die A now known to the collector of U. S. envelopes, there were in use then, numbers 4, 6, 7, 10, 11 and 12. Whether or not these were really the earliest types of Die A we cannot decide, but it would seem reasonable to think that the absence of Type I with Head I of Washington indicates that this Head was not issued to the public during 1853.

For a more detailed description with illustrations of the Heads and seals or tresses the reader is referred to my article on the subject in THE PHILATELIC GAZETTE for May 1914.

To finish the above list of U. S. envelopes issued during 1853, we must add the following five.

YEAR 1853. 3c. DIE B.

| | Date | Paper | Type | Head | Tress | Post Office |
|----|---------|-------|------|------|---------|-------------|
| 1. | Aug. 23 | White | 3 | | no seal | New York |
| 2. | Aug. 26 | White | 2 | | no seal | New York |
| 3. | Oct. 6 | White | 3 | | no seal | New York |
| 4. | Oct. 20 | White | 2 | | no seal | New York |
| 5. | Nov. 1 | White | 3 | | no seal | New York |

Among the number of envelopes the dates of which can be identified by their enclosures, are the following, all used during 1854.

YEAR 1854. 3c. DIE A.

| | Date | Paper | Type | Head | Tress | Post Office |
|-----|----------|-------|------|------|---------|-------------------|
| 1. | Jan. 7 | White | 6 | IV | no seal | Cincinnati |
| 2. | Jan. 21 | White | 3 | Ia | no seal | New York |
| 3. | Jan. 25 | White | 12 | | no seal | New York |
| 4. | Feb. 2 | White | 6 | IV | no seal | New York |
| 5. | Feb. 9 | Buff | 5 | III | no seal | Boston |
| 6. | Feb. 13 | White | 3 | Ia | no seal | New York |
| 7. | Apr. 19 | White | 8 | VI | no seal | New York |
| 8. | Apr. 27 | Buff | 6 | IV | no seal | Jackson, Mich. |
| 9. | July 6 | White | 10 | VIII | no seal | New York |
| 10. | July 11 | White | 4 | II | no seal | New York |
| 11. | July 12 | White | 4 | II | no seal | New York |
| 12. | July 27 | White | 4 | II | no seal | New York |
| 13. | Sept. 5 | White | 4 | II | no seal | Providence, R. I. |
| 14. | Sept. 30 | White | 12 | X | no seal | New York |

DIE B.

| | Date | Paper | Type | Head | Tress | Post Office |
|----|---------|-------|------|------|---------|---------------|
| 1. | Feb. 27 | White | 3 | | no seal | New York |
| 2. | Nov. 13 | White | 2 | | no seal | Newark, N. J. |

An examination of the envelopes listed 1853 and 1854 reveals that of Die A we have Types 3 to 8 and 10-12, while Types 1, 2 and 9 are not represented; also that of Die B we have only Types 2 and 3. Despite the failure to find representations of these types in the lot of envelopes it would be rash to assume that not all types of Dies A and B were used simultaneously in the manufacture of stamped envelopes, especially as Dr. Harrison states that the first type of watermark—there being several—is found with Head I or Types 1, 1a, 2, and 2a, and this watermark is thought to be the one which was used first by Nesbitt. The next die, Die E, in which the letter T of CENTS has a long cross stroke, appears as early as September 11, 1854, and is type 5. Of types 2 and 3 we find dates Oct. 21 and Aug. 8 respectively.

If any reader of THE PHILATELIC GAZETTE possesses other information so far not published, bearing on the first date of issue of U. S. stamped envelopes, he is respectfully requested to communicate with the writer. For the benefit of this most important branch of American Philately we cannot afford to relax our efforts to build up a solid historical foundation.

CHECK LIST OF U. S. STAMP BOOKS.

COMPILED BY W. H. DOLE.

In the list as published in the May issue of the GAZETTE, the following corrections are to be noted.

| | | | | | | |
|----|---|-----|---|---|--------|---|
| 4. | 2c carmine, scarlet, carmine lake, etc. (Shield Type) | | | | | |
| g | C | I | " | " | Yellow | } "The Registry System" 28 mm. } "(British Honduras, effective Jan. 1, 1905)" } 3rd cover page. |
| h | C | II | " | " | Buff | |
| i | C | III | " | " | Gray | |
| gg | C | I | " | " | Buff | } "The Registry System" 26 ½ mm. |
| hh | C | II | " | " | Yellow | |
| ii | C | III | " | " | Gray | |

The note under No. 10 with reference to the 396 copies issued with the experimentally waxed paper should refer to 10d instead of 10a, the former of which only was issued in this manner.

U. S. ENVELOPES 1911-15, 1c DIE C, 2c DIE D.

Up to date list of all known varieties.

BY J. MURRAY BARTELS.

| B.No. | Denom. | Die Var. | Size | Paper | Wmk. | Kn. |
|-------|--------|----------|------|--------|------|-----|
| 2300 | 1c | C v. 1 | 8 | White | 16 | 59 |
| 2301 | 1c | C v. 1 | 8: | White | 16 | 59 |
| 2302 | 1c | C v. 1 | 8: | Amber | 16 | 59 |
| 2303 | 1c | C v. 1 | 13 | Amber | 16 | 83 |
| 2393 | 1c | C v. 1 | 6: | Manila | 17 | 75a |
| 2394 | 1c | C v. 1 | 8: | White | 17 | 59 |
| 2395 | 1c | C v. 1 | 8: | Amber | 17 | 59 |
| 2466A | 2c | D v. 4 | 5 | Amber | 17 | 84 |
| 2467 | 2c | D v. 1 | 7 | White | 17 | 51 |
| 2467A | 2c | D v. 1 | 7 | Amber | 17 | 51 |
| 2467B | 2c | D v. 1 | 7 | Blue | 17 | 51 |
| 2468 | 2c | D v. 3 | — | Manila | 17 | W |
| 2469 | 2c | D v.13 | — | Manila | 17 | W |
| 2507 | 2c | D v. 1 | 7 | White | 18 | 51 |
| 2507A | 2c | D v. 1 | 7 | Blue | 18 | 51 |
| 2508 | 2c | D v. 1 | 7 | Buff | 18 | 51 |
| 2509 | 2c | D v.11 | 8 | White | 18 | 59 |
| 2510 | 2c | D v. 5 | 9 | White | 18 | 61 |

NEW KNIVES

| | | | | | | |
|--------|----|--------|----|-------|----|----|
| 2533 | 1c | C v. 1 | 5 | White | 16 | 87 |
| 2613b | 2c | D v. 2 | 5 | White | 17 | 87 |
| 2613c | 2c | D v. 3 | 5 | White | 17 | 87 |
| 2613d | 2c | D v. 4 | 5 | White | 17 | 87 |
| 2613e | 2c | D v. 5 | 5 | White | 17 | 87 |
| 2613f | 2c | D v. 6 | 5 | White | 17 | 87 |
| 2613h | 2c | D v. 9 | 5 | White | 17 | 87 |
| 2613i | 2c | D v.10 | 5 | White | 17 | 87 |
| 2613j | 2c | D v.11 | 5 | White | 17 | 87 |
| 2614a | 2c | D v. 1 | 5 | Amber | 17 | 87 |
| 2614b | 2c | D v. 2 | 5 | Amber | 17 | 87 |
| 2614d | 2c | D v. 4 | 5 | Amber | 17 | 87 |
| 2614f | 2c | D v. 6 | 5 | Amber | 17 | 87 |
| 2614g | 2c | D v. 7 | 5 | Amber | 17 | 87 |
| 2614h | 2c | D v. 8 | 5 | Amber | 17 | 87 |
| 2614i | 2c | D v. 9 | 5 | Amber | 17 | 87 |
| 2614j | 2c | D v.10 | 5 | Amber | 17 | 87 |
| 2614Aa | 2c | D v. 1 | 5 | Buff | 17 | 87 |
| 2614Ab | 2c | D v. 2 | 5 | Buff | 17 | 87 |
| 2615 | 2c | D v. 3 | 13 | White | 17 | 89 |
| 2615A | 2c | D v. 3 | 13 | Amber | 17 | 89 |
| 2615B | 2c | D v. 3 | 13 | Blue | 17 | 89 |
| 2615C | 2c | D v. 3 | 13 | Buff | 17 | 89 |
| 2644a | 1c | C v. 1 | 5 | White | 18 | 87 |
| 2644b | 1c | C v. 2 | 5 | White | 18 | 87 |
| 2645 | 1c | C v. 2 | 5 | Amber | 18 | 87 |
| 2673a | 2c | D v. 1 | 5 | White | 18 | 87 |
| 2673b | 2c | D v. 2 | 5 | White | 18 | 87 |
| 2673d | 2c | D v. 4 | 5 | White | 18 | 87 |
| 2673f | 2c | D v. 6 | 5 | White | 18 | 87 |
| 2673g | 2c | O v. 7 | 5 | White | 18 | 87 |
| 2673h | 2c | D v. 8 | 5 | White | 18 | 87 |
| 2673i | 2c | D v. 9 | 5 | White | 18 | 87 |
| 2673j | 2c | D v.10 | 5 | White | 18 | 87 |
| 2673k | 2c | D v.11 | 5 | White | 18 | 87 |
| 2674 | 2c | D v. 3 | 5 | Amber | 18 | 87 |
| 2680a | 2c | D v. 1 | 13 | White | 18 | 89 |
| 2680c | 2c | D v. 3 | 13 | White | 18 | 89 |

NOTE: Wmk. 16: u. s. pod 1911; Wmk. 17: USSE 1911; Wmk. 18: US-SE 1911.

New shapes of envelopes are knives 87 to 92.

For full description of the types or die varieties see Bartels' Entire Envelope Catalogue page 102 or Kohl plate XI A.



Published the 15th day of each month

J. KLEMMANN, Jr., Editor.

CLIFTON A. HOWES, Special Contributing Editor.

JOHN A. KLEMMANN, Managing Editor.

Staff Writers.

CHARLES LATHROP PACK

J. MURRAY BARTELS

A. E. OWEN

B. W. H. POOLE

VICTOR M. BERTHOLD

DR. CARROLL CHASE

W. B. SPRAGUE

SUBSCRIPTION \$1.00 A YEAR, SINGLE NUMBERS 10c.

Advertising Rates

| | 1 mo. | 3 mos. | 6 mos. | 9 mos. | 12 mos. |
|--------------|--------|--------|--------|---------|---------|
| 1 inch | \$1.50 | \$4.00 | \$7.75 | \$11.50 | \$15.00 |
| ¼ p. | 5.00 | 13.50 | 26.25 | 38.00 | 50.00 |
| ½ p. | 8.50 | 23.00 | 44.50 | 65.00 | 85.00 |
| 1 page | 15.00 | 40.50 | 78.75 | 114.75 | 150.00 |

NASSAU STAMP CO., Publishers, 118 NASSAU ST., NEW YORK.

VOL. V, No. 6

NEW YORK, JUNE, 1915.

WHOLE No. 70.

EDITORIAL.

With this, our June issue, we again present our enlarged quarterly number. It is our desire to effect this change permanently throughout the year, but it can only be done by and with the cooperation of our readers. We need more subscriptions and if you know a fellow collector who does not get the GAZETTE, drop us a line and a sample copy will be sent him.

A. P. S.

On another page will be found, nominations for the officers of the A. P. S. for the ensuing year, made by a group of New York members and the Philadelphia Branch.

It is needless to call attention to the personnell of this ticket, each member of which is a well known philatelist and active in the affairs of the Society.

We will be glad to lend our support to this ticket as we feel sure its election will insure the high standard of efficiency established by the former officers.

Our Managing Editor, Mr. John A. Klemann, expects to attend the Convention and will be glad to act for any local members who are unable to go. Mail your proxies to the GAZETTE office.

THE HOBBY OF STAMP COLLECTING.

BY CHARLES LATHROP PACK.

(Author of "Fun with the Cheap Stamps of Brazil," "The Diligencia Stamps of Uruguay," "Plating the First Issue of Victoria," etc.)

There are times when every active mind should have a hobby and indeed needs it. The fact that medical men have always been great "hobby riders" strongly suggests that it is not merely an innocent pastime, but is of great constructive and practical value.

I collected stamps when a boy at school in Canada, but I first became a specialist in the real study of stamps some fifteen years ago when trying to divert and help a young man who was confined much of the time to an invalid rolling chair. Since then it has become a genuine help on occasions when I myself have been laid low.

Many doctors, the world over, are collectors of stamps. Notable examples will on consideration occur to those who care to give the subject only a few minutes thought. Here in the United States there are more than a thousand physicians who take an active interest in philately and some of them have become authorities.

Some of our best writers, like Weir Mitchell, Oliver Wendell Holmes, and Conan Doyle are notable examples of physicians who have ridden hobbies by writing novels or poetry. Some wonderful collections of birds and ceramics have been brought together as a hobby by other doctors. A doctor in Philadelphia is well-known because of the collections he has made from time to time of the most varied objects—autographs, bookplates, weapons and specimens of natural history.

Mr. H. Addington Bruce has recently said: "This fondness for hobbies must largely be attributed to the fact that in spite of the exacting duties imposed on them, the average span of life for physicians is longer than that for most men. Diversion of mind, through concentrated interest in some entertaining avocation, is among the surest prescriptions for health and long life. It is also in many cases one of the most helpful remedies for disease.

"So true is this that today the 'hobby cure' is among the recognized modes of treating functional nervous and mental troubles, the basic cause for which is always unhealthy preoccupation with thoughts of self. Not a few specialists in the treatment of this disease have effected 'miraculous' cures by nothing more than providing their patients with hobbies appropriate to their peculiar temperaments and capacities."

I think that everyone should have a hobby of some sort, one that can be resorted to particularly in those times in life when the right sort of a diverting stimulus is most desirable. The one thing to be sure of, is that you ride your hobby and not let your hobby ride you. The hobby particularly of stamp collecting properly cultivated, gives a zest to existence undreamed of by those who allow themselves to become slaves to the treadmill of routine.

In these times of the Great World War everyone has greater responsibilities and this entails a greater strain on humanity than has ever been known before. The man who is blessed with a stamp collectoin will do well if he can snatch but only a few moments a week, for its peaceful stimulus will surely better prepare him for the taxing responsibilities which come to every man these days.

BOLIVAR.**The Stamps of 1879-1899.**

By A. HATFIELD, JR., and BERTRAM W. H. POOLE.

(Continued.)

Reprints.

Reprints or, more correctly speaking, unofficial imitations of the 5c, 10c, 20c, and 40c on bluish laid paper imperforate (and perf. 12½) are on the market in considerable quantity and it seems probable they were manufactured at a comparatively recent date. These things differ from the genuine stamps as we shall show and they were printed from new stones. Speaking generally the easiest test by which they can be distinguished from the originals is the absence of the two small dots in the band of stars. These "reprints" are interesting as further corroboration of our theory regarding the manner in which the original stamps were manufactured. Had there been complete original dies for the respective values, and had the originals been used for producing these doubtful impressions, it would be stretching coincidence too far to imagine the two minute dots on the band of stars could have been accidentally removed from all four values. The centers, with the small exceptions noted, and borders correspond too closely with the originals to have been copied and it is evident the original dies for centerpiece and borders were used. When it was desired to make these fancy varieties the strips of transfers or stones originally used were not available so new stones had to be made. It is evident the original head and border dies were found and though it was known the sheets printed in 1879 consisted of fifty stamps it was not recollected that the stones had been laid down in strips of five. In making the stone for the 5c two transfers showing slight differences were used while for the other three denominations three transfers were used.

Although the original die for the portrait, etc., was used the small dots on the band of stars do not show at all and it is difficult to account for their omission. It is hardly likely they could have been noticed and removed intentionally; probably, as these fancy varieties were made many years after the 1879 issue was obsolete, the die had become a little dirty and in making it fit for use the small dots may easily have been erased accidentally.

The two types of the 5c are as follows:—

Type A.—Several of the lines in the spandrel under the numeral in the right upper corner are broken and not so heavy as in the other type.

Type B.—The frame line at left is entirely omitted for a space extending from about 1mm. above the shield to the base of the first segment of the shield. This is very plain.

The sheet arrangement of the types is as follows:—

| | | | | | | | | | |
|---|---|---|---|---|---|---|---|---|---|
| B | B | B | A | B | B | A | B | B | A |
| A | B | B | A | B | A | A | B | B | A |
| B | B | B | A | B | B | A | B | B | A |
| B | B | B | A | B | B | A | B | B | A |
| B | B | B | A | B | B | A | B | B | A |

The three types of the 10c may be distinguished by the following peculiarities:—

Type A.—The right hand frame line of the shield at right is omitted from the lower compartment.

Type B.—The color between the letters OS of CORREOS extends downwards into and nearly across the white line above the portrait.

Type C.—A line of color runs down the tail of the second R of CORREOS and generally extends across the white line above the portrait.



PLATE III.

The following is a diagram of the sheet arrangement of the types for this value:—

| | | | | | | | | | |
|---|---|---|---|---|---|---|---|---|---|
| A | B | C | A | B | C | A | B | C | A |
| A | B | C | A | B | C | A | B | C | A |
| C | B | C | A | B | C | A | B | C | A |
| C | B | C | A | B | C | A | B | C | A |
| B | B | C | A | B | C | A | B | C | A |

The three types of the 20c can be identified as follows:—

Type A.—A line of color projects from the lower side of the right shield and extends outward from the frame line for the space of a little more than $\frac{1}{4}$ mm. The left shield is depressed a little from the frame line but not so much as in type C. There is a small dot of color on the bottom frame line about 1mm from the lower right corner. It seems to cross the frame line and touches the solid color under the letter S of CENTAVOS.

Type B.—There is a colored dash in the left side stroke of the O of BOLIVAR extending in a diagonal direction.

Type C.—The upper left side of the left shield is broken and the right hand shield is depressed from the frame line and shows a space between that line and the shield.

The types are arranged on the sheets in the following manner:—

| | | | | | | | | | |
|---|---|---|---|---|---|---|---|---|---|
| A | B | C | A | B | C | A | B | C | A |
| A | B | C | A | B | C | A | B | C | A |
| B | B | C | A | B | C | A | B | C | A |
| B | B | C | A | B | C | A | B | C | A |
| C | B | C | A | B | C | A | B | C | A |

There are also three distinct types of the 40c which may be distinguished as follows:—

Type A.—There is a colored line in the upper left hand part of the first O of CORREOS, a large colored dot at the base of the upright stroke of the first R of the same word, and a colored line across the white line under the second R.

Type B.—A small irregular circle breaks into the background under the S of CORREOS and extends upwards and nearly across the white line above the portrait. There is also a colored dot at the top of the second R of the same word.

Type C.—There is a circle of color under the second R of CORREOS occupying the whole width of the uncolored line above the portrait. There is another irregular circle in the same space under the S of the same word but more to the right than in type B. At the right of this circle there are two small defects on the lines of the background.

The sheet arrangement of the types is as follows:—

| | | | | | | | | | |
|---|---|---|---|---|---|---|---|---|---|
| A | B | A | C | B | A | C | B | A | C |
| C | B | A | C | B | A | C | B | A | C |
| B | B | A | C | B | A | C | B | A | C |
| C | B | A | C | B | A | C | B | A | C |
| A | B | A | C | B | A | C | B | A | C |

The design of the 10c also differs from the originals in having small lines on the space below the date at top.

Although these stamps were printed on bluish laid paper it is not exactly like the paper used for the originals. The laid lines are more clearly defined and there are lines crossing them at intervals of about 21mm. There also seems to be a slight difference in the horizontal laid lines about every 22mm. giving a sort of quadrille effect, but this may be caused by some peculiarity of printing for it is always visible in the same place on the stamps.

In one other respect these posthumous varieties differ from the originals and that is in the matter of color. Some of the 5c and 10c are tolerably like the 1879 stamps but as a rule they are found in much brighter tints. The 20c varies greatly and all sorts of colors such as orange-red, orange-yellow, vermilion, carmine-red, and carmine may be found. The 40c is nearly always found in a bright shade of yellow brown.

(To be continued.)

A Detailed History of the General Issues of United States Postage Stamps from 1847 to 1890.

By

CARROLL CHASE, ARTHUR E. OWEN AND WILLIAM B. SPRAGUE.

Alterations of the National Bank Note Co's Dies of the 1870 Series of United States Postage Stamps.

With notes relative to plate varieties of the printings by the National, Continental and American Bank Note Companies.

(Continued from page 75.)

One Cent. (Continued.)

The "shifted transfer" varieties in this denomination are numerous, no less than twenty-two different ones having been noted, and these all in the Continental or American Co's printings. The most notable example has the frame design of the lower half of the stamp shifted to the bottom and the left about 0.01 in. and the upper right half of the frame design a similar distance to the right, the duplication of design being particularly noticeable in the words "ONE CENT" and "TAGE" of Postage. This shift evidently occurred on one of the later Continental plates, as copies are known on both hard and soft porous paper. The other shifts show more or less duplication of various parts of the design, and in some the only evidence of the error of plate making is in a slight duplication to the right or left of the ends of the lines of the background shading.

Two Cents.

The die block of the two cent stamp is 3 in. high and 2.46 in. wide, and the stamp design is spaced equally distant from the sides and from the top and bottom of the block. The corners of the block are rounded and edges bevelled, as in the case of the one cent die block and shows the National Co's imprint in the same style letters as the one cent die, in fact, these characteristics are to be found in all the National Co's dies of this series. The engraving of this die is admirable and there are no minor defects requiring correction before making the plates. The guide line and position dot, see b, Fig. 1, p. 74, are found only on the National Co's plates.

The secret mark of the Continental Co. on the National 2 cent die consists of a slight change in the vertical linework beneath the colorless ball to the left of the "S" of "U. S.". This mark is generally described as being an added short diagonal line at this point and on some proofs and lightly inked, clearly printed impressions of the stamps, a line of this character may be distinguished, but an examination of the die leads one to the conclusion that an attempt was made to cut some sort of a mark on the hardened die at this point, and the result was merely to affect the design slightly, which produced in the plate impressions a small spot of color. Proof sheets from the unhardened Continental Co's plates have been examined, and a variety of "secret marks" can be seen. Generally speaking, the presence of color between the vertical shade lines is indicative of the work of the Continental Co., although lightly inked impressions or those from worn plates resemble the National Co's stamps, and the shade of the ink and character of paper used must be taken into account in their proper classification.

An interesting variety of the Continental printing shows a vertical hair line 0.02 in. from the right side of the stamp. This line shows in the stamps of the last vertical row of the left pane and probably extends from the top to the bottom of the plate.

There are a few shifted die varieties in the Continental and American printings, in which the duplication of the design is very slight. The original National Co's die with the Continental Co's secret mark is known in the Bureau as P. O. No. 132.

Three Cents.

The die block of the three cent stamp is slightly smaller than those of the two preceding denominations, and measures 2.88 in. in height with a width of 2.44 in. The stamp design is 0.90 in. and 0.99 in. from the top and bottom of block respectively, and equally distant from the sides of the block.

There is a slight defect in this die, the vertical shading under the numeral 3 extending slightly below the lowest horizontal line of the stamp design. These marks were removed from some of the reliefs on the National Co's transfer rolls, but not from all, as we find stamps printed by that Co. both with and without these lines, and as this is also true of the Continental Co's impressions, the presence or absence of this defect cannot be used to classify the printings. The guide line and position dot, similar to that shown at b, Fig. 1, p. 74, are present on the National Co's plates, but only early printings show the guide line, and its presence combined with the position dot is evidence of the National Co's impressions; but as many of the American Bank Note Co's stamps show a position dot, see f, Fig. 2, p. 74, it is best to rely on the secret mark placed on the die to classify the three cent stamp properly.

This mark consists of the widening of the shade line below the right fork of the ribbon end below the letters R E of THREE. It is probably the most deeply cut of any of the secret marks, and on impressions from worn plates is very prominent. The original National die with the addition of this secret mark is indexed at the Bureau as P. O. No. 137. It is of interest to note that in the book of proofs issued by the Post Office Dept. in 1904, entitled "United States—Postage Stamp—1847—1902. Proofs" that the impression from Die No. 137 is included in the Series of 1882, while the so-called re-engraved die is placed in the 1870 Series.

The alteration of the design of the three cent stamp by the American Bank Note Co. in 1881 was not done on the original National die, as was the case with the one cent stamp. A new die block, 2.90 in. by 2.50 in. in size was made, probably with an ordinary transfer roll made from the National die as altered by the Continental Co., and while all the elements of the design of the original National die are retained, a different aspect is given to the engraving by the widening of a number of the lines together with the addition of others. The changes are as follows:

- (a) Additional vertical shade lines in the background of the portrait medallion.
- (b) Additional diagonal lines and widening of lines in the left shoulder of the bust.
- (c) Widening of all vertical lines of the shield.
- (d) Widening of the horizontal lines in the background of the shield, excepting those on the right side above the angle in the shield above the letter S in CENTS.
- (e) Extension of diagonal shade line below the shield and under the right side of the numeral 3 to the lower horizontal line of the stamp design.
- (f) The additional widening of the sixth (counting from the bottom) horizontal shade line under the letters TS for a distance of 0.06 in. This is the mark described in the catalogues as "A short horizontal dash has been cut about 1 mm. below the "TS" of "Cents."
- (g) The widening of the shade lines below the four forks of the ribbon label which bears the words "Three Cents."

All of these changes and additions are more or less discernible on the issued stamps, but those described above in paragraphs e, f and g will be sufficient to indicate to the collector that a stamp showing any of them belongs to the Series of 1882.

The die block above described is indexed as P. O. No. 138 and bears the inscription "Worked over by the New Company, June 29, '81."

A. E. O.

(To be continued.)

SHORT NOTES AND NEWS.

Aeroplane Mail Service Data.

On October 2, 1911, the Postmaster at St. Louis, Mo., was authorized to collect and deliver mail by aeroplane at aviation meet on Fair Grounds from October 4 to 8, 1911. On one date mail was carried from Aeroplane Station No. 1, Aviation Fields, the Fair Grounds, a distance of twelve miles, in 10¾ minutes. About 25,000 pieces of mail were carried by Aviators Walter Brookins and Hugh Robinson.

On November 2, 1911, the Postmaster at Fort Smith, Ark., was authorized to collect and deliver mail by aeroplane at an aviation meet on November 5, 1911, and to establish a temporary station at the fair grounds. Aviators Beckwith Havens and Lincoln Beachey carried 25,000 pieces of mail.

On April 18, 1912, a pouch of mail was carried from the aviation grounds to the post office at Eureka, one trip, one way, by aeroplane without expense to the Post Office Department, by Aviator Cook, who carried 147 pieces of mail.

On May 25, 1912, Aviators Harry N. Atwood and Arch Freeman carried 3340 pieces of mail from Cliftondale to Lynn, Mass., one trip, one way, by aeroplane, without expense to the Post Office Department.

The Postmaster at Salem Depot, N. H., was authorized to dispatch mails on May 30, 1912, from Rockingham Park, N. H. to Lawrence, Mass., a distance of four miles, one trip, one way by aeroplane, by Aviator Lincoln Beachey, but he made the trip without mail.

The Postmasters of Cicero, Elmhurst and Wheaton, Ill., exchanged mails on May 30, 31, June 1 and 2, 1912, one round trip each day, by aeroplane, by a sworn carrier and without expense to the Post Office Department, but the name of aviator or amount of mail carried were not reported.

On August 3, 1912, from aviation grounds at Kohekus Track to the post office at Ridgewood, N. J., one trip, one way, Aviator George Richter carried 1662 pieces of mail.

The Postmaster at Cincinnati, Ohio, was authorized to dispatch mail on July 19, 20 and 21, 1912, from Coney Island to the post office at California, Ohio, one trip, one way, each day. Aviator Paul M. Beck carried 560 pieces of mail.

From July 22 to 27, 1912, from the Fair Grounds to the post office at Providence, Ky., Aviator Horace Kearny carried the mail.

Postmaster, Cedar Falls, Iowa, authorized to dispatch mail from temporary station at aviation grounds to post office at Cedar Falls, on September 5 and 6, 1912, one trip one way, each day, by sworn carrier and without expense to the Department. Aviator Lincoln Beachey carried the mail; amount not reported.

The Postmasters at Celeron, Sodus Point, Chautauqua and Mayville, N. Y., were authorized to exchange postal cards only by hydro-aeroplane as often as practicable from May 30 to September 7, 1914, and Aviator A. J. Engle carried 27 pieces of mail.—Postmasters Advocate.

It is not often that the newspapers criticize the productions of the Bureau of Engraving and Printing, so that the editorials in the New York Sun of June 8th and the replies thereto of Third Assistant Postmaster General Dockery and Director Ralph of the Bureau of Engraving and Printing in the Sun for June 13, are of such interest to philatelists generally that we print them in full.

Editorial, New York Sun, June 8.

The Burleson Shoddy Two Cent Postage Stamp.

This is a word that ought to be sufficient, addressed in all gentleness to those who ought to be wise.

The Government document or letter which comes most intimately and remains most constantly in relation with the daily life of the hundred millions of Americans is the two cent postage stamp. It is the unit of mail communication. It is beloved by all; tolerated when it brings the butcher's

bill, blessed when it becomes the motor of the missives of Cupid. It is not too much to say that in the domestic affection of most people the two cent postage stamp ranks immediately after the members of the family and the savings bank account.

Well we remember, notwithstanding the many years that have elapsed, the cyclonic storm of indignation that swept over every part of this republic when the post office authorities, in some whimsy conceived in hebetudinous fatuity, undertook to substitute for the agreeably dry red of the then existing two cent stamp a thing of horror printed in a particularly nauseating pale green. We do not believe that any veteran in the establishment at Washington over which the Hon. Albert S. Burleson now presides has forgotten the historic incident of the Sickly Green Stamp.

Mind you, there was no question of the deterioration in the quality of the paper, in the regularity of the perforation, in the adequacy of the adhesive smearing. The offence was mainly against good taste, the sin was purely aesthetic. Yet not for that reason was the popular uprising (which, it may perhaps be proper to observe, The Sun had the honor to organize and to lead to victory) less prompt, less fierce in its just wrath, less overwhelming in its practical unanimity. If the Post Office Department had not surrendered by the withdrawal of the spinach splashed tombstone which it had fatuously put forth as a two cent stamp—had not the Post Office Department gracefully placated the public indignation by restoring the cherished color of aurora and rose-buds—it is quite conceivable that the Administration might have gone to smash. Thrones have been overturned for less heinous crimes against the people's rights.

For weeks reaching into months the purchasers of Mr. Burleson's two cent stamp have noticed with surprise and growing anger that it is not the good old reliable two cent stamp to which they had been accustomed. The hue of the ink has changed but slightly, if at all; the mucilaginous coating on the reverse has undergone no marked depreciation in efficiency, but all the crispness and toughness of the texture of the stamp itself has disappeared. This means that an inferior quality of paper is now used, and the most casual inspection of one of Mr. Burleson's postage stamps shows that such is the case. The fibre is so slushy, the paper is so soft, the perforation is so poorly done, that it is a work of delicacy and caution to separate a sheet of these stamps into its component parts without destroying from two to forty of the one hundred units and thus contributing to the revenues of Mr. Burleson's department a considerable percentage of excess taxation for which the Government makes no return in postal service rendered.

It cannot be that Postmaster-General Burleson expects by such petty economies, by such impositions on the citizen-customers of his department, to amass revenue to be squandered in carrying farm products long distances by mail and semi-socialistic experiments of that sort.

Let him remember the Sickly Green postage stamp!

Reply of Third Assistant Postmaster General Dockery.

New York Sun, June 13.

To the Editor of The Sun—Sir: I have read with interest your editorial article of June 8 on "The Burleson Shoddy Two Cent Postage Stamp," in which the quality of postage stamp paper is criticised.

The issuance of stamps happens to be a part of my official duties, and feeling confident of your desire to make any needed correction of articles appearing in the columns of The Sun I venture to address you briefly for the purpose of stating the facts in regard to the stamps as I know them to exist, and the steps already taken by the Post Office Department with reference to them.

The editorial article referred to alleges in effect that the stamps cannot be separated from each other without tearing them, and attributes the difficulty to the use of inferior paper. It is true that while ordinarily little or no trouble is experienced, occasionally an effort to separate the stamps in haste results in a torn stamp. This slight tendency to tear is not, however, due to any deterioration in the quality of the paper used. Some months ago the Bureau of Engraving and Printing, which manufactures the Government's postage stamps under contract with this Department and obtains all paper

and other materials used, asked permission to widen the spacing between perforations for the purpose of stopping the heavy loss caused by the splitting apart of the stamps in course of production, and for the further purpose of obviating the annoyance to the public and the difficulties experienced by post office employees from premature separating. The Department authorized this wider spacing, upon condition that it should be changed if experience showed it to be unsatisfactory.

The wider spacing naturally increases somewhat the strength of the paper along the lines of perforation, and when the stamps got into circulation a few reports were received that they did not separate quite so easily as former issues. The Department promptly took the matter up with the Bureau of Engraving and Printing, which has prepared a new set of perforating wheels designed to punch the holes closer together than is now the case, but not so close as to cause the accidental separating of stamps from mere handling, which formerly resulted in annoyance to the public and loss to the Government. It is confidently believed that these new perforations will overcome the difficulty, but if not nothing will be left undone to correct the cause of complaint.

A. M. DOCKERY,

Washington, June 11.

Third Assistant Postmaster-General.

**Reply of Director Ralph
of The Bureau of Engraving and Printing.**
New York Sun, June 13.

To the Editor of The Sun—Sir: Convinced as I am by long acquaintance that The Sun would not knowingly do any one an injustice, I beg to call attention to the fact that the editorial article of June 8 headed "The Burlington Shoddy Two Cent Postage Stamp" places the blame for the defeat complained of in the stamps upon the Postmaster-General when as a matter of fact it should be laid on the Bureau of Engraving and Printing.

The editorial article complains that an inferior quality of paper is now used and that the most casual inspection of one of the stamps would show this to be the case as "the fibre is so slushy, the paper is so soft, the perforation is so poorly done, that it is a work of delicacy and caution to separate a sheet of stamps into its component parts without destroying from two to forty of the one hundred units."

It is no doubt true that in attempting to separate the stamps the difficulty encountered would lead one to believe that the fault is due to inferior paper, but this is not so, as the standard quality has been fully maintained and the paper now in use is equal, if not superior, to any heretofore used.

The fact is that for many years the stamps were perforated with the perforations close enough together to permit of the stamps being readily separated without mutilating them, but as the automatic stamp vending machinery was developed and stamp affixing machines were devised it was found necessary to modify the style of perforating to meet the needs of these machines and the perforations were consequently placed further apart. This made the paper stronger along the line of perforation than in the printed part of the stamp in many cases, and as a result, while the stamps were perfectly adapted for the mechanism of the vending machines, they gave difficulty to consumers who used them in sheets. By direction of the Postmaster-General steps have been taken to remedy this defect by making a closer perforation, which it is believed will entirely obviate any cause for complaint.

While the article states with regard to the two cent stamps that the hue of the ink is changed but slightly, if at all, I would add as pertaining to this subject that it would not have been surprising if the criticism of the stamp had referred entirely to the color, as it is a fact that the stamps that have been issued for the past several months have been of various shades of red, in some cases so decidedly different from the standard that it has been expected that some public criticism would be made regarding it. This variation is due to the fact that the bases of many of the colors used in printing are manufactured in Germany and since the war began it has been very difficult to procure sufficient supplies of regular colors to maintain the standard colors of the stamps. Fortunately by quick action at the beginning of the war in procuring as large supplies as possible it has been prac-

licable to maintain an approximation to the standard, but there is a possibility that if the war should continue for a considerably longer period it may be necessary to change the shade of this color entirely.

I deem it my duty to write you on this subject in justice to the Postmaster-General for the reason that he is entirely blameless with regard to the change in the style of perforation that has given rise to the difficulty on which your article is based.

JOSEPH E. RALPH,

Director of the Bureau of Engraving and Printing.

Washington, June 11.

AUCTION REPORT.

J. C. Morgenthau & Co., 97th Sale.

| Lot No. | | |
|---------|--|-------|
| 1 | U. S., 1847, 5c red brown (28), unused, o. g., | 12.75 |
| 3 | — — 5c dark brown (28a), unused, o. g., | 12.75 |
| 43 | — — 10c black, used on original, | 12.10 |
| 45 | — — 10c black on white paper, used on original, | 8.25 |
| 92 | — 1851, 5c red brown (34), used, | 9.50 |
| 99 | — — 10c green (35), horizontal strip of 5, used, | 10.75 |
| 100 | — — 12c black (36), unused, o. g., | 15.00 |
| 106 | — — Lower left diagonal half of 12c black used as 6c (36a) with 3c red (33), on cover, | 25.50 |
| 107 | — 1857, 1c blue, vertical pair, the lower stamp type I (40), the upper type II, (41), unused, o. g., | 25.00 |
| 112 | — — 1c blue, type III, laid paper, (42b), unused, o. g., | 25.00 |
| 122 | — — 5c orange brown, block of 4, the lower stamps type II (48) the upper type III (49), unused, o. g., | 18.75 |
| 146 | — — Reprints, 24c dull violet, | 10.10 |
| 149 | — — — 90c blue, | 16.10 |
| 161 | — 1861, 24c red lilac (70), unused, o. g., | 21.50 |
| 168 | — — 90c blue (72), unused, o. g., | 12.10 |
| 179 | — 1867, embossed all over, 3c rose (79), unused, o. g., | 25.00 |
| 196 | — — 9x13, 24c gray lilac (99), unused, o. g., | 32.50 |
| 216 | — 1869, 90c black and carmine (122), unused, | 21.50 |
| 219 | — — Re-issue, 3c blue (125), unused, o. g., | 11.00 |
| 245 | — 1873, 3c green, double paper, (158d), pair, unused, o. g., | 17.80 |
| 282 | — 1898, 15c olive (284), blurred print, block of 4, unused, o. g., | 14.25 |
| 348 | — 1914, Kansas City Roulette, 1912, 1c green (347), block of four, | 4.30 |
| 349 | — — — 2c carmine, (348), block of 4, | 5.30 |
| 379 | — Postal Savings, \$1.00 ultramarine (637), vertical strip of 4, unused, o. g., | 10.50 |
| 391 | — Carriers, Charleston, Honour, 1851, 2c black on bluish, (829), used, on cover, | 30.50 |
| 435 | Bangkok, 1883, 2c on 32c red orange (21 G 13), unused, o. g., | 17.00 |
| 517 | Cape of Good Hope, 1853, Blued Paper 1p brick red (1), block of 4, used, | 10.50 |
| 657 | Iceland, 1902, 50a blue and carmine (67), block of 9, 1 stamp the error "02'-03" (67c), unused, o. g., | 16.25 |
| 658 | — — 100a brown and violet (68), block of 8, 1 stamp the error "02'-03" (68d), used, | 12.50 |
| 662 | — — 10a blue (176) block of 4, 1 stamp the error "03-03" (176c), unused, o. g., | 9.50 |
| 684 | Malta, 1860, ½ p buff on bluish (2), block of 4, unused, o. g., | 26.50 |
| 772 | Philippines, 1901, \$1.00 black (223), full circle at left, unused, o. g., | 7.00 |
| 910 | Tasmania, 1853, 4p red orange (2), horizontal strip of 3, used, | 12.50 |
| 951 | Turks' Islands, 1881, 2 ½ p on 1s violet (20a), unused, o. g., | 17.00 |
| 962 | Victoria, 1850, 3p blue (3), horizontal pair, used, | 8.25 |
| 974 | Western Australia, 1854, 1s pale brown (5), horizontal pair, used, | 8.10 |
| 975 | — — Roul. 4p blue (8), unused, | 17.50 |

Nassau Stamp Co. 50th Sale.

Lot No.

| | | |
|-----|--|--------|
| 4 | U. S., 1847, 5c brown on original cover, magenta cancellation, | 5.00 |
| 17 | — 1851, type 4, 1c blue, unused, full o. g., | 3.10 |
| 26 | — — 10c green, horizontal strip of 3, used, | 6.20 |
| 28 | — — 10c green, vertical strip of 3, used, | 7.30 |
| 29 | — — 10c yellow green, horizontal pair, used, | 3.00 |
| 30 | — — — vertical pair, used, | 3.20 |
| 80 | — 1862, 24c steel blue, used, | 9.00 |
| 84 | — 1867, grided 11x13, 12c black, unused, nearly full o. g., | 11.25 |
| 134 | — 1895, watermarked U.S.I.R., 6c dull brown, used, | 75.00 |
| 143 | — 1901, 4c Pan American, center inverted, surcharged specimens, unused, o. g., | 35.00 |
| 184 | — State, \$5.00 green and black, unused, no gum, | 102.00 |
| 193 | — 1879, soft porous paper, Agriculture, 1c yellow, block of 4, unused, | 125.00 |
| 205 | — Carrier, Baltimore, 1852, 1c blue, unused, o. g., | 25.00 |
| 207 | — — Charleston, Steinmeyer, 1858, 2c black on pink, unused, o. g., | 16.50 |
| 208 | — — 2c black on yellow, unused, o. g., | 20.00 |
| 262 | — Newspaper, 1894, \$3.00 scarlet, unused, o. g., | 75.00 |
| 331 | — Revenues, 1902, \$50.00 green and black, unused, o. g., | 75.00 |

SOCIETY NOTES.**The Washington State Philatelic Society.**

The Washington State Philatelic Society extends a cordial invitation to philatelists who are planning to attend the Exposition in San Francisco and the A. P. S. Convention, to plan their route via Seattle and Puget Sound. The trip East from Seattle is a most beautiful one and the scenery can not be equalled anywhere in the United States.

The Society will show every courtesy to visiting philatelists and endeavor to give them a good time.

Just drop the Secretary a line stating time of arrival and length of stay. Address, Box 1912, Seattle, Wash.

C. R. CALLAHAN, Secretary.

A. P. S., New York Branch.

Although this branch has been inactive in the affairs of the Society for some time, a number of the members feeling that New York should take a more active part, have placed in nomination the following ticket:

For President, C. A. Howes of Massachusetts.
 For Vice President, Carroll Chase of New York.
 For Vice President, W. B. Sprague of New York.
 For Vice President, H. H. Wilson of New York.
 For Secretary, W. E. Ault of Indiana.
 For Treasurer, C. F. Heyerman of Michigan.
 For Director at Large, H. B. Phillips of California.
 For Director at Large, W. H. Barnum of Ohio.

| | | |
|-------------------|---------------------|--------------------|
| J. M. Barte's, | W. F. Gregory, | Van Dyk Mac Bride, |
| V. M. Berthold, | J. A. Klemann, | Vahan Mozian, |
| P. L. Chambers, | J. J. Klemann, Jr., | A. E. Owen, |
| C. Chase, | H. M. Lewy, | W. B. Sprague, |
| J. B. Chittenden, | J. N. Luff, | H. H. Wilson. |

National Philatelic Society.

On July 22, 23, 24, 1915, the National Philatelic Society will hold its Third Annual Convention in New York City. This is the first stamp convention to be held in New York in 15 years, and from reports received the attendance will be the largest ever seen in New York at a convention of this kind. The Committee on Arrangements (Charles R. Goetz, Chairman, 77 West 85th Street, New York, Tel: Schuyler 5303) have met several times to

formulate plans to entertain the visiting members. The Convention will be called to order on July 22d, at 8 P. M. in the large Ball Room of the Aschenbroedel Hall, 144 East 86th Street, headquarters of Branch No. 3.

On July 24th, the visiting members will be the guests of the New York Philatelic Exchange Society on a trip to Coney Island, Luna Park, &c., for which two special cars have been engaged.

New York Philatelic Exchange Society, Branch No. 3, The National Philatelic Society.

The 30th meeting will be held at 144-6 East 86th St., "Aschenbroedel", New York City (second floor) on Monday, June 28, 1915 at 8 P. M., and thereafter on the second and fourth Mondays of the month. You are requested to be present and bring a fellow collector with you. The usual open bourse, sales, exchange and club auctions are the leading features.

The National Philatelic Society has over 300 members in all parts of the United States and abroad. Maintains sales and exchange departments for its members. The New York Branch has 95 members. Dues are low in comparison to the benefits. If you wish to increase your collection and friends join us. 75 per cent. of the members attend the meeting. This society is now one of the largest and most progressive stamp societies in Greater New York.

GEORGE HOLDEN, Secretary.

New York Stamp Society.

Tuxedo Hall, Madison Ave. & 59th St.

The 253d meeting was called to order at 8:45 P. M., June 3d by President Klein.

Minutes of the previous meeting were read and adopted.

The Secretary read a letter from Mr. C. L. Gwyer at Santos, resigning from the Society and expressing the hope of rejoining on his return to America.

The Secretary also read a letter from the Merchants Association of New York, requesting the Society to use its influence in having the next Convention of the American Philatelic Society in New York, in 1916. The members feel, however, as another city is most anxious to have the Convention for that year, it would perhaps be better not to join in extending the invitation at this time. Should the Convention be held here at some future year, we will be pleased to join with the Merchants Association of New York and others to insure the American Philatelic Society a most hearty welcome.

Mr. Elwood Banfield was elected to membership.

Mr. Klein reported that the certificates to be given to the "Exhibit Winners" were almost ready and would be shown at the next meeting.

Mr. Forrest P. Hand's collection of Columbian "registered envelopes" was shown by Mr. Klein. We regret Mr. Hand could not attend in person and thank him for the privilege of seeing his collection. We also trust he will be with us at some future meeting.

There were 25 members present, and Mr. and Mrs. C. J. Gregory who we trust will give us the pleasure of seeing them again.

Meetings are held regularly on the 1st and 3d Thursdays of every month. Visitors always welcome.

G. DENZAU, Secretary.

Pacific Philatelic Society, Branch No. 3.

The regular 311th meeting was held on Wednesday eve May 19, at the Club rooms of the Society, Oscar Luning Building, #45 Kearny St., San Francisco.

Present: President, Phillips; Vice-President, F. Marcus; Messrs. Dr. Fischer, Dr. Holt, Merrell, Steinman, Smith, Johnson, Dillingham, Lazarus, Weber, Secretary Marcus. Visitor: Wm. Homan, Hotel Astor, New York, Pres. Collectors Club.

Reading of minutes of 310th meeting, approved as read.

Reading of the report of the Committee on Programs. Committee given one month further to complete same.

Report on Badges. Approved as read. Secretary authorized to order same.

Report of Committee on Photograph. Approved as read.

Report on Transportation. Committee gave sketch of Bay and Trolley trips for the Convention and estimate of costs, which were approved, Secretary being authorized to pay same on presentation of bills.

Committee on Banquet approved by Chair with full powers to act in behalf of the Society. F. G. Marcus, H. G. Smith.

The name of Frank E. Clark presented to the Committee on Membership to be voted on as a member at the next regular meeting. Nominated by Dr. Holt, seconded by Dr. Fischer.

Mr. C. M. Wade being recommended by the Committee on Members, was duly elected a member on ballot.

Mr. Steinman was appointed a Committee of one to confer with the Numismatic Society regarding their Convention to be held in August.

The exhibit of stamps of China and Corea brought out three wonderful collections in these countries.

Committee of awards reported as follows:

| Credits | | Marcus Bros. | Phillips. | Weber. |
|--------------|-----|--------------|-----------|--------|
| Completeness | 25 | 15 | 5 | 20 |
| Condition | 25 | 20 | 20 | 25 |
| Mounting | 15 | 10 | 10 | 15 |
| Rarities | 35 | 25 | 5 | 30 |
| Total | 100 | 70 | 40 | 90 |

F. G. MARCUS, Secretary.

Philadelphia Branch # 18 A. P. S.

At a meeting of Philadelphia Branch # 18 A. P. S., held on June 4th, the following nominations for officers of the American Philatelic Society were made:

- For President, C. A. Howes, of Massachusetts.
- For Vice-President, H. H. Wilson of New York.
- For Vice-President, Wm. B. Sprague of New York.
- For Vice-President, Dr. Carroll Chase of New York.
- For Secretary, Wm. E. Ault, of Indiana.
- For Inter. Sec'y, L. Harald Kjellstedt of Pennsylvania.
- For Treasurer, C. F. Heyerman of Michigan.
- For Director at Large, H. B. Phillips of California.
- For Director at Large, W. H. Barnum of Ohio.

The Branch unanimously recommends the reappointment of P. M. Wolfieffer for Sales Manager for the ensuing year of 1915-16.

A. F. HENKELS, Secretary.

The Rhode Island Philatelic Society.

The 247th regular meeting of the Rhode Island Philatelic Society was held at the Narragansett Hotel with President Chambers in the chair and eleven members present. In the absence of the Secretary Mr. H. N. Gibbs was appointed Secretary pro tem.

Minutes of the last meeting approved as read.

Application of Howard W. Preston received and voted to act upon it at next meeting.

Mr. Littlefield's application for membership in the Society having been approved by the Executive Committee he was unanimously elected.

Mr. Streeter's resignation from the Society was accepted with regret.

A communication from the "Philatelic Gazette" in regard to the publishing of reports of the Society's monthly meetings in that paper was received and it was voted to send the reports.

Report of Treasurer read, approved, and ordered placed on file.

Report of Sales Manager read and accepted.

H. N. GIBBS, Secy. pro tem.

An agreement has been effected between the United States and the Netherlands, making the rate of postage from the United States to the Dutch Possessions in America including the island and continental colonies 2 cents.

UNITED STATES

are of all stamps most popular. We are remounting our splendid approval books adding much new material. These we will gladly submit to responsible collectors. The following are some of the best. ★ means unused only.

- ★ No. 1 **1847-1890**, finest condition, stamps from \$2 to about \$30. General issues.
- ★ No. 2 **1847-79**, finest condition, stamps from 25c to \$4.
- ★ No. 3 **1847-88**, Liberal discounts. Good grade, 50% or more off catalogue.
- ★ No. 4 **Special Bargains**, Stamps with trifling imperfections. Enormous discounts.
- ★ No. 5 **1870-82**, Fine copies, shades, etc.
- ★ Nos. 7-13 **1890-1902** Each issue in shades.
- ★ No. 15 **Departments**, finest grade.
- ★ No. 16 **Postage Due**, splendid shades.
- ★ No. 20 **General issues**, Fine copies, 10c-\$2 each.
- No. 20A **General issues**, odd cancellations, nice lot.
- No. 21 **Same**, Fine copies of scarce stamps, \$2 up.
- No. 22 **1847-1908**, Special bargains at very substantial discounts, some have slight imperfections.
- No. 23 **1870-82**, the different printings.
- Nos. 28-40 are in **Blocks of 4**.
- ★ No. 28 **1851-88** a few nice things left.
- ★ No. 30 **1890**, Many fine shades.
- ★ No. 32 **1894**, Good line of shades.
- ★ No. 33 **1895-98**, Very popular.
- ★ No. 35 **1902-07**, Grand lot of shades.
- ★ No. 36A **1908**, Strong in shades.
- ★ Nos. 38, 39, **Postage Due**, in shades.
- No. 43 **U. S. Locals**.
- No. 45 **Revenues**, old issues, \$2 up.
- ★ No. 47 **Same 1898-1902**, blocks in shades.
- No. 48 **Telegraph stamps**.
- ★ Nos. 49 to 63 **U. S. Envelopes**, cut square.
- No. 64 **Plate Proofs**, card or India.
- No. 81 **Philippines**, 1854-88. Grand lot.
- ★ No. 87 **Philippines**, U. S. Issues only.
- ★ No. 93 **U. S. Colonies**. For album spaces.

For full list of U. S. and Foreign Sections see our **Pink list**. It describes over 200 different books. Sent free.

J. M. BARTELS CO.

99 Nassau St., New York



Made in America

Interchangeable Leaves

BLANK ALBUMS - \$4.00 and up
STOCK BOOKS - \$2.00 and up

Used by the foremost Collectors and Dealers
 Complete price list free on request



"Ne Plus Ultra" Watermark Revealer
 Price 50c. Postage 10c. extra

All "Ne Plus Ultra" supplies manufactured exclusively by
SCOTT STAMP & COIN CO.
 127 Madison Ave.  New York City

99th SALE

June 29, 30, 1915.

Europe Part II.

Holland & Colonies—Italian States
 Luxemburg—Norway.
 Portugal and Colonies.
 Catalogue mailed on request.

J. C. Morgenthau & Co.
87 Nassau St., New York

Confederates

Locals and Carriers

What have you to offer?
Send at your lowest cash price.

JOHN A. KLEMMANN
118 Nassau St. New York

THE PHILATELIC GAZETTE

PUBLISHED MONTHLY FOR STAMP COLLECTORS

VOL. V, No. 7.

NEW YORK, JULY, 1915.

WHOLE No. 71.

COPYRIGHT, 1915, BY THE NASSAU STAMP CO.

THE CONFEDERATE STATES OF AMERICA.

A HISTORY OF THE GENERAL ISSUES.

BY BERTRAM W. H. POOLE.

I. Introduction.

From a historical viewpoint, the postal issues of the short-lived Confederate States of America are of even more interest than those of the United States itself. Philatelically, too, they are of the greatest interest and though the various stamps have been extensively studied they still offer plenty of scope for original research. Indeed, of none of the issues can it be said that the last word has been written, and some, notably the engraved 10c stamps, regularly bristle with knotty problems which, perhaps, may never be satisfactorily solved. Certainly little can be added to our present knowledge of these stamps unless more material than is at present available is unearthed.

At the time these stamps were issued, philately almost had numerous votaries, and though, when victory finally fell to the North and the country was beginning to return to normal conditions, enquiries were almost immediately made regarding many points connected with the history of the Confederate stamps, much of the information obtained was vague in the extreme or quite unreliable, and it was left to later investigators to elucidate many of the more doubtful points.

It is probably more than thirty years ago that attention was first centered in these stamps on what I may perhaps term "modern" lines of investigation, and in 1887 Major Edward B. Evans wrote a scholarly monograph on the subject in the "American Philatelist" and, four years later, re-wrote and amplified the whole in the columns of the "Monthly Journal." It speaks much for the gallant Major's treatment of the subject that though his last article appeared nearly a quarter of a century ago little of real importance has since been added to our knowledge of these stamps. Major Evans' article is so comprehensive that it must obviously form the basis of any further study of these Confederate issues and to it I am indebted for much valuable information.

But, in the main, I am indebted to Mr. John A. Klemann for the opportunity of examining and studying his wonderful collection of these stamps—a collection strong in large blocks, entire sheets, and dated covers,—without which it would have been impossible to give much of the following information.

It is rather surprising and certainly regrettable that more has not been published on Confederate States stamps in American philatelic literature. So far as I am aware no really important article on the subject has been printed, though there have been a number of excellent short notes dealing with isolated facts or items in the history of these stamps.

II. Historical.

It is, I think, hardly necessary to enter into a lengthy dissertation regarding the many political and historical questions which led to the secession of the States forming the Confederacy. Suffice it to say that for many years the foremost question in the minds of the people related to slavery. In the North sentiment against it was growing rapidly, due, in some measure to the agitations of the abolitionists, and partly, to the literature of the day, represented principally by Mrs. Harriet Beecher Stowe's "Uncle Tom's Cabin". At the presidential election of 1860, Abraham Lincoln, the champion of the slaves, was elected by a triumphant majority. Immediately upon the news of the election South Carolina formally dissolved the Union fearing that, with Lincoln as president, their extensive slave properties would soon be abolished. As the Union of the States had long been an accomplished fact and its permanence in the North was considered paramount, the right of any State to secede was emphatically denied. Other Southern States, however, jealous of their state rights and fearing for the stability of their slave properties, followed the lead of South Carolina and claimed the right to secede from the Union. By February, Georgia, Alabama, Florida, Louisiana, and Mississippi had all withdrawn; and though they evidently did not contemplate a permanent disruption, they thought they could make better terms out of the government than in it. Accordingly a convention met in Montgomery, Alabama, in February, 1861, and adopted a provisional Constitution for the "Confederate States of America", Jefferson Davis being chosen president. The Federal Government was, at the same time, greatly disconcerted by the resignation of many military officers, who entered the Confederate service. On April 12th. the troops of South Carolina fired on Fort Sumter, in Charleston Harbor, a national fort, and it surrendered. War had begun. The next day President Lincoln called for 75,000 volunteers and the North quickly responded to the call. During the first year of the war Virginia, North Carolina, Tennessee, Missouri and Texas threw in their lot with the South so that by December, 1861, the Confederacy had grown from six to eleven States, with about nine millions of people on its side. Kentucky and Maryland did not secede but a large proportion of their population were in sympathy with the South. The seat of government was removed to Richmond and in February, 1862, a permanent government was organized in place of the Provisional Congress. At the first meeting under the new Constitution Jefferson Davis was elected president to serve for a term of six years but as events subsequently transpired he was not destined to complete his term of office. The new Congress was composed of two houses, similar to those of the National Legislature at Washington, and to a very large extent the laws were fashioned on those of the Federal Government. In fact at the first Provisional Congress an Act was approved which continued in force "all laws of the United States * * * * not inconsistent with the Constitution of the Confederate States."

The victories at the beginning of the war were with the Confederates, and the national Capital was greatly endangered by the retreat from Manassas. Almost at the outset the North barely escaped an unpleasant imbroglio with Great Britain, by the seizure of two Confederate envoys who had run the blockade and taken passage on the British mail steamer *Trent*. This breach of international law was immediately disavowed, and the envoys were surrendered. By 1862 the plan of the war began to develop. In the east the objective points lay between Washington and Richmond, the respective capitals; while in the west the armies sought to control the valley of the Mississippi. In the east Robert E. Lee and "Stonewall" Jackson began their brilliant and successful campaign against the Federal army, and the year ended with the overwhelming defeat of the North at Fredericksburg. The war in the west, however, was more successful. General Grant marched into the seceding country, took Corinth, and opened the Mississippi as far as Vicksburg, the river having been cleared below by the victory of Admiral Farragut at New Orleans. The capture of Memphis soon followed. The western counties of Virginia separated from the parent State in 1862 and in 1863 were admitted to the Union as West Virginia. President Lincoln, although strongly opposed to slavery, was at first averse to freeing the slaves, but in September, 1862, he proclaimed that, unless the seceding States re-

turned to their allegiance by the first day of the ensuing year, he would declare the slaves free. By this act the sympathy of the European powers for the South was neutralized, and the dread that the Confederacy would receive foreign recognition was dissipated.

In 1863 the South lost Stonewall Jackson, one of its ablest commanders; and Lee, in his attempt to invade Pennsylvania, met with a bloody defeat at Gettysburg (July 1-3). At the same time the news of the capture of Vicksburg by Grant filled the North with renewed hope. These victories were shortly followed by others at Lookout Mountain and Missionary Ridge. The persistent manner in which Grant succeeded made him one of the most conspicuous generals in the Union army; consequently, in 1864, he was given supreme command. Leaving Sherman in charge of the western army, he himself went east, where he assumed command of the Army of the Potomac. But he met with severe losses at the beginning of his campaign, and the long siege of Lee's fortified position was not broken until the spring of 1864, when Grant began to move upon the Confederate forces at Richmond and Petersburg. Lee was at last compelled, by the advance of Sherman, to evacuate Richmond, and made an attempt to reach the Confederate forces in the far south; but in this he failed, and on April 9th. he was forced to surrender to General Grant at Appomattox Court House, but on honorable terms, and the war was over.

III. Philatelic History.

The philatelic history of the Confederate States opens with the issue of lithographed 5c and 10c stamps in October, 1861, followed a few months later by a 2c denomination produced by the same process. The postal authorities looked upon these lithographed productions as a temporary expedient, as it was considered the process hardly provided sufficient safeguards against successful counterfeiting; but, owing to difficulties in the way of obtaining anything superior, their use continued for quite an extensive period compared with the sum total of the life of the Confederacy itself. In the early months of 1862 5c stamps were obtained from London, printed from electrotyped plates, but as the arrival of shipments was uncertain it would appear that the locally produced stamps of the same denomination still continued to be printed. Ultimately one or more of the London plates was shipped to the Confederacy and printings were made locally, but the Government officials were still anxious for line-engraved stamps, as this method of manufacture was deemed immune from the counterfeit danger besetting lithography. In May, 1863, this wish was gratified and 2c, 10c, and 20c stamps were printed from line-engraved plates.

It will thus be seen that the stamps of the Confederacy fall naturally into three groups according to the methods of production—lithographed, typographed, and line-engraved. Moreover these different processes were made use of in chronological sequence and, at first sight, a classification of the stamps on these lines has much to commend it. There was, however, a certain amount of overlapping and, more important still, different printers were entrusted with the production of stamps of similar value, type, and color, at different times. As it is now possible to identify the work of these different firms the rough and ready division into lithographed, typographed, and line-engraved groups, can no longer appeal to the advanced student and specialist. It would appear, therefore, that the most satisfactory and logical arrangement is that following the sequence of the various printers, and that is the plan I purpose following in this article. Our consideration of the Confederate States stamps will, thus, fall under the following headings:—

- Stamps printed by Hoyer and Ludwig.
- Stamps printed by De La Rue & Co.
- Stamps printed by J. T. Paterson & Co.
- Stamps printed by Archer and Daly.
- Stamps printed by Keatinge and Ball.

By following this plan we can not only give proper consideration to the differences in impression, paper, etc. characterising the productions of the different printers, but we also preserve the strict chronological order in which the respective stamps appeared and at the same time we can, in the main, consider the lithographed, typographed, and line-engraved groups in this sequence.

IV. Inauguration of the Postal Service.

One of the first official actions of the Provisional Congress was to pass an Act "to continue in force certain laws of the United States of America", the laws relating to postal matters being adopted *en bloc* among other things. Shortly afterwards, on March 15th, 1861, a new Act was approved which repealed the old postal rates. As this is of particular interest I reproduce it in full:—

NEW POSTAGE ACTS.

Notice to the Public and Instructions to Postmasters.

The following laws have been enacted by the Congress of the Confederate States of America:

Letter Postage

AN ACT to prescribe the rates of postages in the Confederate States of America, and for other purposes.

The Congress of the Confederate States of America do enact, that from and after such period as the Postmaster-General may by proclamation announce, there shall be charged the following rates of postage, to wit: For every single sealed letter, and for every letter in manuscript or paper of any kind, upon which information shall be asked for or communicated in writing, or by marks or signs, conveyed in the mail for any distance between places within the Confederate States of America, not exceeding five hundred miles, five cents; and for any distance exceeding five hundred miles, double that rate; and every letter or parcel not exceeding half an ounce in weight, shall be deemed a single letter, and every additional weight of half an ounce, or additional weight of less than half an ounce, shall be charged with additional single postage; and all packages containing other than printed or written matter, and money packages are included in this class, shall be rated by weight as letters are rated, and shall be charged the rates of postage on letters; and all drop letters, or letters placed in any post-office not for transmission but for delivery only, shall be charged with postage at the rate of two cents each; and in all the foregoing cases the postage must be prepaid by stamps; and all letters which shall hereafter be advertised as remaining over or uncalled for in any post-office shall be charged with two cents each in addition to the regular postage, both to be accounted for as other postages of this Confederacy.

Postage on Newspapers, Pamphlets and other Printed Matter, including Books.

And be it further enacted, That all newspapers published within the Confederate States, not exceeding three ounces in weight, and sent from the office of publication to actual and *bona fide* subscribers within the Confederate States, shall be charged with postage as follows, viz., The postage on the regular numbers of a newspaper published weekly shall be ten cents per quarter; papers published semi-weekly, double that amount; papers published thrice a week, treble that amount; papers published six times a week, six times that amount; and papers published daily, seven times that amount. And on newspapers weighing more than three ounces, there shall be charged on each additional ounce in addition to the foregoing rates on those published once a week, five cents per ounce, or fraction of an ounce, per quarter; on those published twice a week, ten cents per ounce per quarter; on those published three times a week, fifteen cents per ounce per quarter; on those published six times a week, thirty cents per ounce per quarter; and on those published daily, thirty-five cents per ounce per quarter.

And periodicals published oftener than bi-monthly, shall be charged as newspapers.

And other periodicals, sent from the office of publication to actual *bona fide* subscribers, shall be charged with postage as follows, viz., The postage on the regular numbers of a periodical, published within the Confederate

States, not exceeding one and a half ounces in weight and published monthly, shall be two and a half cents per quarter; if published semi-monthly, double that amount. And periodicals published quarterly or bi-monthly, shall be charged two cents an ounce; and regular subscribers to newspapers and periodicals shall be required to pay one quarter's postage thereon in advance, at the office of delivery, unless paid at the office where published.

And there shall be charged upon every other newspaper, and each circular not sealed, or handbill, engraving, pamphlet, periodical, and magazine, which shall be unconnected with any manuscript or written matter, not exceeding three ounces in weight, and published within the Confederate States, two cents; and for each additional ounce, or fraction of an ounce, two cents additional; and in all cases the postage shall be prepaid, by stamps or otherwise, as the Postmaster-General shall direct.

And books, bound or unbound, not weighing more than four pounds, shall be deemed mailable matter, and shall be charged with postage, to be prepaid by stamps or otherwise, as the Postmaster-General shall direct, at two cents an ounce for any distance.

And upon all newspapers, periodicals, and books, as aforesaid, published beyond the limits of the Confederate States, there shall be charged postage at double the foregoing specified rates.

The publishers of newspapers and periodicals within the Confederate States may send and receive to and from each other, from their respective offices of publication, one copy of each publication, free of postage.

All newspapers, unsealed circulars, or other unsealed printed transient matter, placed in any post-office, not for transmission but for delivery only, shall be charged postage at the rate of one cent each.

Franking Privilege.

And be it further enacted that from and after the day when this Act goes into effect the franking privilege shall be abolished: Provided, that the Postmaster-General and his chief clerk, the chiefs of the Contract, Appointment and Finance Bureaus, and the Auditor of the Treasury for the Post-office Department, shall be and they are hereby authorized to transmit through the mail, free of postage, any letters, packages, or other matters relating exclusively to their official duties, or to the business of the Post-office Department, and they shall in every such case indorse on the back of the letter or package to be sent free of postage, over their own signature, the words "Official Business". And for any such indorsement falsely made, the person so offending shall forfeit and pay three hundred dollars. And provided, further, the several deputy postmasters throughout the Confederate States shall be and hereby are authorized to send through the mail, free of postage, any letters and packages which it may be their duty or they may have occasion to transmit to any person or place, and which shall relate exclusively to the business of their respective offices or to the business of the Post-office Department, but in every such case the deputy postmaster sending any such letter or package shall indorse thereon, over his own signature, the words "Post-office Business". And for any and every such indorsement falsely made, the person making the same shall forfeit and pay three hundred dollars.

Payment of Postage in Money until Postage Stamps and Stamped Envelopes are Provided.

Section 1.—The Congress of the Confederate States of America do enact, That, until postage stamps and stamped envelopes can be procured and distributed, the Postmaster-General may order the postage of the Confederacy to be prepaid in money, under such rules and regulations as he may adopt.

Repeal of the Letter Registration System.

And be it further enacted, That the third section of an Act entitled "An Act further to amend an Act entitled an Act to reduce and modify the rates of postage in the United States, and for other purposes, passed March

3, 1851", approved March 3, 1855, whereby the letter registration system was established, be and is hereby repealed from and after the day when this Act goes into effect.

Conveyance of Mail Matter by "Express" and other Chartered Companies.

Section 5.—That it shall be lawful for the Postmaster-General to allow express and other chartered companies to carry letters and all mail matter of every description, whether the same be enclosed in stamped envelopes or prepaid by stamps or money, but if the same be prepaid in money, the money shall be paid to some postmaster, who shall stamp the same paid, and shall account to the Post-office Department for the same, in the same manner as for letters sent by the mail; and if prepaid by stamps, then the express or other company receiving such letters for delivery shall obliterate such stamps, under the penalty of five hundred dollars for each failure, to be recovered by action of debt in any court having jurisdiction thereof, in the name of the Postmaster-General, for the use of the Confederate States, but if said letters or mail matter shall be received by such express or other company, not for delivery, but to be mailed, then the matter so carried shall be prepaid at the same rate that the existing law requires to be paid from the point where it may be received by such company to the point of its destination, and the postmaster, where such company mail the same, shall deface the stamps upon the same.

Section 6.—Be it further enacted, that agents of any company who may carry letters under the provisions of this Act, shall be required to take an oath that he will faithfully comply with the law of the Confederate States relating to the carrying of letters or other mail matter, and obliterating postage stamps, which oath may be administered by any justice of the peace, and shall be in writing, and signed by such agent or messenger, and filed in the Post-office Department.

The postal rates and regulations enacted by the above decree went into effect on June 1st, 1861, and they remained in force until July 1st., 1862, when they were revised as shown by the following official circular which was approved on the preceding April 19th.

RATES OF POSTAGE.

No. 61. AN ACT to amend an Act entitled "An Act to prescribe the rates of postage in the Confederate States of America, and for other purposes.

Section 1.—**The Congress of the Confederate States of America do enact,** That from and after the first day of July next, there shall be charged the following rates of postage, to wit: For every single letter sealed, and for every letter in manuscript or paper of any kind, upon which information shall be asked for, or communicated in writing, or by marks and signs, conveyed in the mails for any distance within the Confederate States of America, ten cents; and every letter or parcel not exceeding half an ounce in weight shall be deemed a single letter, and every additional half ounce, or additional weight of less than half an ounce, shall be charged with an additional single postage.

It will be noted that the effect of the above circular was to double the postage on letters sent distances of less than five hundred miles within the confines of the Confederacy. This increase probably accounts for the fact that so many pairs of 5c Confederate stamps are found.

A second circular, dated June 10th, 1863, deals with the postage on books, newspapers, etc. and with regard to this I cannot do better than reproduce Major Evans' comments thereon:—

It increases the rates by charging 1 cent upon every copy of a newspaper sent to a subscriber, instead of the charge being in the proportion of 10 cents per quarter for a weekly paper, and an additional $\frac{1}{2}$ cent per ounce is levied on all periodicals exceeding three ounces in weight. This, however, does not affect the stamp question, as on all matters of this nature the post-

age continued to be paid quarterly in advance, and the papers were not stamped. The postage upon other newspapers, circulars, pamphlets, etc., was made 1 cent per ounce, without any apparent limit of weight, but books were still charged 2 cents per ounce. It seems to have been left to Postmasters to determine at what size or weight a volume ceased to be a pamphlet at 1 cent per ounce, and became a book at two cents per ounce. We see, however, that even after June, 1863, there was a use for one cent stamps, although it seems certain that none of the one cent stamps were ever used.

(To be continued.)

BOLIVAR.

The Stamps of 1879-1899.

By A. HATFIELD, JR., and BERTRAM W. H. POOLE.

(Continued.)

IV. The 1880 Issue.

The 1880 issue consists of six different values, the 5c, 10c, 20c and 40c being of the same designs as the corresponding denominations of the preceding set, but with the date altered to "1880", while the 80c and 1 peso are similar as regards the portrait but differ in the spandrel ornamentation. This latter corresponds to that of the so-called essays of 1879. The four lower values were issued about July, 1880, but the two higher denominations did not appear until much later. Indeed, the earliest mention we can find of them in any of the philatelic journals is March, 1882.

Like the stamps of 1879 this issue was printed from lithographic stones, all six values being in sheets of fifty, arranged in five horizontal rows of ten each. The stones were made up in the same manner as those for the 1879 series so we again find five minor varieties of type of each value with the following sheet arrangement:—

| | | | | | | | | | |
|---|---|---|---|---|---|---|---|---|---|
| 1 | 1 | 1 | 1 | 1 | 1 | 1 | 1 | 1 | 1 |
| 2 | 2 | 2 | 2 | 2 | 2 | 2 | 2 | 2 | 2 |
| 3 | 3 | 3 | 3 | 3 | 3 | 3 | 3 | 3 | 3 |
| 4 | 4 | 4 | 4 | 4 | 4 | 4 | 4 | 4 | 4 |
| 5 | 5 | 5 | 5 | 5 | 5 | 5 | 5 | 5 | 5 |

The similarity between the two issues, 1879 and 1880, is so marked that it is obvious the same methods were followed in their manufacture and, with necessary alterations, the same dies were undoubtedly used. The head die, as we have already explained, consisted of the portrait, surrounding inscribed band, and shields, and that this was used for all the values of the 1880 series is proved by the presence of the two small dots of color on the band of stars described in chapter III. That the 1879 border dies were made use of for the series now under notice will be shown as we deal with the different denominations.

The 5 centavos.

In the case of the 5c the best evidence we can adduce in proof of the fact that the same border die was used lies in a small colored dot shown on the white line of the lower border immediately underneath the V of CENTAVOS. This is clearly marked on every stamp on the sheets of both issues. In making up the stone for the 5c it is possible the same strip of five transfers was used as was employed for the 1879 emission, though the small peculiarities distinguishing types 1, 3, and 5 of the earlier set are not now visible. But whether the original strip was used or a fresh one made it is interesting to note that the alteration of date from 1879 to 1880 was undoubtedly made on the transfers and not on the original border die. The result is that the figures of "1880" differ on each of the five types, frequently



T1



T2



T3



T4



T5



T1



T2



T3



T4



T5



T1



T2



T3



T5



T1



T2



T3



T4



T5

PLATE IV

show traces of the previous numerals, and are the simplest test for differentiating the five varieties in each vertical row. The main points of difference are as follows:—

Type 1. (First row).—There is a dot of color on the top of the first "8" of the date, and a faint colored dash over the second "8" but a little to the right.

Type 2. (Second row).—The "1" of the date is distinctly double and the right end of the line below is irregular and curves downwards.

Type 3. (Third row).—The space between the upper and lower segments on the left side of the second "8" of the date is filled with color.

Type 4. (Fourth row).—A small colon is shown between the lower parts of the numerals "1" and "8" of the date and the "0" is irregular in its outline on the lower left inner side.

Type 5. (Fifth row).—The numerals "18" of the date are lower than "80". The lower segment of the first eight is broken on the left side and the line below is broken in two places.

There are flaws on some of the stamps by means of which their positions on the sheet can be determined but the only one of any importance is # 10 where the vertical stroke of the "5" at left is continued upward through the frame.

The 10 centavos.

The five types of this value are a little difficult to distinguish, the chief points of difference being as follows:—

Type 1. (First Row).—The "0" of "1880" is broken on the lower right hand side.

Type 2. (Second Row).—The "0" of "1880" is raised nearly to the top frame line, and there is a small colored dash under and somewhat to the right of this numeral.

Type 3. (Third Row).—There is a small dash between the second "8" and the "0" of "1880" which sometimes looks like a cluster of small dots. There is also a very tiny colored dot slightly above the centre of the "0".

Type 4. (Fourth Row).—The numerals "18" of the date are badly formed or have been damaged. The "1" has a thickening of the lower end and there is a blurred thickening of the left side of the "8".

Type 5. (Fifth Row).—There is a faint colored dash under and slightly to the right of the first "8" of "1880", and there is generally a faint microscopic dot to the right of the "0" of the date about $\frac{1}{2}$ mm. distant from the numeral.

The 20 centavos.

The stone for the 20c follows the same arrangement and the five types are much easier to identify than those of the corresponding value of 1879. Here again we find the alteration of date was made on the transfer paper so that not only do the numerals differ on all five types but on some (types 2 and 4 in particular) traces of the original numerals are quite apparent. The distinguishing marks of the five types are as follows:—

Type 1. (First Row).—There is a colored dot above and to the right of the R of BOLIVAR.

Type 2. (Second Row).—There is a small colored spot on the colored background directly above the head and touching the outer line of the background.

Type 3. (Third Row).—The uncolored line below the inscription under the portrait is thickened below U. DE and touches those letters. In other parts the line is much too thin and in many respects resembles type 5 of the 1879 series. A tiny colored line crosses the right hand frame line about the centre of the lowest segment of the shield.

Type 4. (Fourth Row).—A tiny colored line projects diagonally upwards from the left end of the value tablet. The "0" of "1880" is broken on its right side.

Type 5. (Fifth Row).—The white line does not show at all below E. E. U. U. DE, and there is a large colored dot on the bottom frame line below the V of VEINTE.

The 40 centavos.

In making up the stone for the 40c the same method was followed and we thus find the numerals of the date differ in shape on each of the five types. The tail of the "9" of "1879" is plainly visible under the "0" of "1880" on type 1, and traces of the original figures are also shown below the "18" of "1880" on type 2. All five types are fairly easy to distinguish, the marks of identification being as follows:—

Type 1. (First Row).—There is a colored line below the "0" of "1880".

Type 2. (Second Row).—The date slopes downwards from left to right and there are distinct colored lines below the figures "18".

Type 3. (Third Row).—The lower half of the second "8" of the date is misshapen and the lower of the two frame lines above is broken just over the same numeral.

Type 4. (Fourth Row).—The solid color extends slightly over the top left corner of the second E of the inscription above CERTIFICADO, and there is a small colored dot in the compartment of the band of stars immediately below that letter.

Type 5. (Fifth Row).—The "1" of "1880" is distinctly doubled.

The 80 centavos.

The stone for this value seems to have been made up in a different manner—like that of the so-called essay of similar facial value of the 1879 series. Apparently the stone was made up from a transfer of the 1879 die with the date removed and the figures "1880" were then drawn on each of the fifty stamps by hand. Thus instead of having five fairly easily distinguished types we have fifty minutely differing varieties. Indeed the differences are so minute that a written description is hardly practicable. There are numerous defects and several broken figures some of which might easily be mistaken for errors of date. Thus the fifth stamp on the bottom row plainly reads "1886" while on many of the other stamps the first "8" is so badly formed that the date might easily be read as "1380". Both these were chronicled so long ago as 1892 as errors of date by M. Moens but they are due to nothing more important than small flaws so that their philatelic importance is slight. A photographic reproduction might enable the reader to plate this curious sheet, but a written description would entail an enormous amount of labor and in the end would prove more or less inadequate.

The 1 peso.

The stone of this denomination seems to have been made up in the same manner as that for the 80c. That is to say instead of the five types found in the 5c, 10c, 20c and 40c each stamp on the sheet of fifty appears to show slight differences. Evidently the stone was made up from a single transfer and, as in the case of the 80c, the date was drawn in separately on each stamp. Numerous defects may be found, especially in the figures of the date and the frame line enclosing it. Any one wishing to do so could reconstruct the sheet if furnished with a good photograph to work from.

Paper.

All six values were printed on ordinary white wove paper and all except the 80c are also known on bluish laid paper. When the 5c, 10c, 20c and 40c on the bluish laid paper were issued is not known for the philatelic journals of the period seem to have let their advent pass entirely unnoticed. The 1 peso on this paper appears to have been entirely unknown until the remainders were marketed in 1894. Though a very rare stamp it is doubtful that it was ever placed on sale in Bolivar. They can probably best be described as stamps prepared for use but never issued. Indeed, although the 5c, 10c, 20c and 40c values on this paper are known cancelled, it is probable none of them were ever on sale in Bolivar but were found among the remainders in 1894.

Perforation.

The stamps of this series, like those of 1879, were all perforated $12\frac{1}{2}$ by a single line machine.

Imperforate varieties.

The 5c on white wove paper entirely imperforate is fairly common and all the other denominations on this paper are also known imperforate, as well as the 20c error of color which will be alluded to shortly. Among the stamps on bluish laid paper the 5c, 10c, 20c and 40c are also found imperforate. The remarks made with regard to the similar varieties of the 1879 issue equally well apply here. We have no grounds to imagine that any of them ever reached Bolivar and were placed in use and their true status is undoubtedly that of unfinished stamps.

Error of color.

The 20c of this series, like the corresponding value of 1879, is known printed in green instead of red. There seems no reason to believe that any of these 1880 stamps ever reached the Bolivar post-office—in fact the error does not appear to have been known or mentioned in any of the philatelic papers until the remainders were sold in 1894. But, as we shall show later in dealing with the unfinished double-sheets of this and the preceding issue, there are good grounds for the belief that most if not all of the 1879-1880 stamps were produced at the same time and, that being the case, as an error of color as made in the 20c stamp of 1879 a corresponding error in the 20c stamp of 1880 was bound to occur. As we have already stated in the preceding paragraph this error is found imperforate as well as with the usual $12\frac{1}{2}$ perforation.

(To be continued.)

THE POSTAL ISSUES OF AUSTRIA.

BY J. BRACE CHITTENDEN, Ph. D.

(Continued.)

NOTE 4. **Failures in perforations.** These exist as follows:

- a. Three sides perf. one imperf. 1, 2, 3, 5, 10, 12, 15K. and 1, 2G.
- b. Perforations diagonally across the corners, 12K.
- c. Top $10\frac{1}{2}$, bottom $9\frac{1}{4}$, sides $12\frac{1}{2}$ (Philatelist, 1908, P. 141.)
- d. 1K. vertical pair, imperforate between, unused, \$15.00.
- e. 3K. horizontal pair, imperforate between, unused.
- f. 5K. horizontal or vertical pair, imperforate between, unused, \$6.25.
- g. 15K. horizontal or vertical pair, imperforate between, unused, \$12.50.
- h. 1G. vertical pair, imperforate between, unused.
- i. 2G. horizontal pair, imperforate between, used, \$50.00.
- j. Perforated twice (2, 5, 10, 24, 50K.).
- k. Spacing of the parallel perforations wide or narrow.
- l. Imperforate (1-30K. and 2G.) \$2.50 to \$5.00 used.

NOTE 5. From Dec. 31st, 1899 to Jan. 1900 the 1K. black was halved to meet the new 1 Heller rate (post cards and packages). Entire on card quoted at \$5.00. The 2K. halved and used as 2 Hellers is considered to be a speculative effort not worth considering as the 1K. value served for that purpose.

For completeness and as a reference table the table given by Kropf and the Societe Francaise is added.

TABLE 27.

Complete perforation table. Issue of 1890.

| Perfs. | Kreuzers | | | | | | | | | | Guldens | | | |
|-----------------|----------|---|---|---|----|----|----|----|----|----|---------|----|---|---|
| | 1 | 2 | 3 | 5 | 10 | 12 | 15 | 20 | 24 | 30 | 50 | 1 | 2 | |
| 9 | 1 | 2 | 3 | 5 | 10 | 12 | 15 | 20 | 24 | 30 | 50 | 1 | 2 | |
| 9 : 9 1/2 | 1 | — | 3 | 5 | 10 | 12 | 15 | 20 | 24 | 30 | 50 | — | 2 | |
| 9 1/2 : 9 | 1 | 2 | 3 | 5 | 10 | 12 | 15 | 20 | 24 | 30 | 50 | 1 | 2 | |
| 9 1/2 : 10 1/2 | 1 | 2 | 3 | 5 | 10 | 12 | 15 | 20 | 24 | 30 | 50 | 1 | 2 | |
| 9 1/2 : 11 1/2 | 1 | — | — | — | — | — | 15 | — | 24 | — | — | — | — | |
| 10 | 1 | 2 | 3 | 5 | 10 | 12 | 15 | 20 | 24 | 30 | 50 | — | — | |
| 10 : 10 1/2 | 1 | 2 | — | 5 | 10 | 12 | 15 | 20 | 24 | — | — | 1 | — | |
| 10 : 11 | — | — | — | — | — | — | — | — | — | 30 | — | — | — | |
| 10 : 11 1/2 | — | — | — | — | 10 | — | 15 | — | — | — | — | — | 2 | |
| 10 1/2 | 1 | 2 | 3 | 5 | 10 | 12 | 15 | 20 | 24 | 30 | 50 | 1 | 2 | |
| 10 1/2 : 10 | 1 | 2 | 3 | 5 | 10 | — | 15 | 20 | 24 | — | — | — | — | |
| 10 1/2 : 11 | 1 | — | — | — | — | — | — | — | 24 | — | — | — | — | |
| 10 1/2 : 11 1/2 | 1 | 2 | 3 | 5 | 10 | 12 | 15 | 20 | 24 | 30 | 50 | 1 | 2 | |
| 10 1/2 : 12 1/2 | 1 | 2 | 3 | 5 | 10 | 12 | 15 | — | — | — | — | — | — | |
| 10 1/2 : 13 1/2 | — | — | — | 3 | 5 | — | 12 | — | — | — | — | — | — | |
| 11 | 1 | 2 | 3 | 5 | 10 | 12 | 15 | 20 | 24 | 30 | 50 | 1 | 2 | |
| 11 : 10 1/2 | 1 | 2 | — | 5 | 10 | 12 | 15 | 20 | 24 | — | — | 1 | — | |
| 11 : 11 1/2 | 1 | 2 | 3 | 5 | 10 | 12 | 15 | 20 | 24 | 30 | 50 | 1 | 2 | |
| 11 : 12 1/2 | — | — | — | — | — | — | 15 | — | — | — | — | — | 2 | |
| 11 : 13 | — | — | — | — | — | — | — | — | — | — | — | — | 2 | |
| 11 1/2 | 1 | 2 | 3 | 5 | 10 | 12 | 15 | 20 | 24 | 30 | 50 | 1 | 2 | |
| 11 1/2 : 9 | — | — | — | — | — | — | — | — | 24 | — | — | — | — | |
| 11 1/2 : 10 | — | — | — | — | — | — | — | 20 | — | — | — | — | — | |
| 11 1/2 : 10 1/2 | 1 | 2 | 3 | 5 | 10 | 12 | 15 | 20 | 24 | 30 | — | 1 | — | |
| 11 1/2 : 11 | 1 | 2 | 3 | 5 | 10 | 12 | 15 | — | 24 | 30 | 50 | 1 | 2 | |
| 11 1/2 : 12 | — | — | — | 5 | — | — | — | — | — | — | — | 1 | — | |
| 11 1/2 : 12 1/2 | — | — | — | 5 | — | — | — | — | — | — | — | 1 | — | |
| 11 1/2 : 13 | — | 2 | — | 5 | — | — | — | — | — | — | — | 1 | — | |
| 11 1/2 : 13 1/2 | — | 2 | — | — | — | — | — | — | — | — | — | — | — | |
| 12 | — | 2 | 3 | 5 | — | — | 15 | — | — | 30 | — | 1 | — | |
| 12 : 10 1/2 | — | 2 | 3 | — | — | — | — | — | — | — | — | — | — | |
| 12 : 11 1/2 | — | 2 | 3 | — | — | — | — | — | — | — | — | 1 | — | |
| 12 : 12 1/2 | — | — | 3 | — | — | — | — | — | — | — | — | 1 | 2 | |
| 12 : 13 | — | — | — | — | — | — | — | — | — | — | — | 1 | — | |
| 12 1/2 | 1 | 2 | 3 | 5 | 10 | 12 | 15 | — | — | 24 | 30 | 50 | 1 | 2 |
| 12 1/2 : 10 1/2 | — | 2 | 3 | 5 | — | — | 15 | — | — | — | — | — | — | — |
| 12 1/2 : 11 1/2 | — | — | — | — | — | — | — | — | — | — | — | 1 | — | — |
| 12 1/2 : 12 | — | 2 | — | — | — | — | — | — | — | — | — | 1 | — | — |
| 12 1/2 : 13 | 1 | — | — | 5 | — | — | — | — | — | — | — | 1 | — | — |
| 12 1/2 : 13 1/2 | — | 2 | — | 5 | — | — | — | — | — | — | — | — | — | — |
| 13 | 1 | 2 | 3 | 5 | 10 | 12 | 15 | — | — | — | — | 1 | 2 | — |
| 13 : 10 1/2 | — | 2 | 3 | 5 | 10 | — | — | — | — | — | — | — | 2 | — |
| 13 : 11 1/2 | — | 2 | 3 | — | — | — | — | — | — | — | — | — | — | — |
| 13 : 12 | — | — | — | — | — | — | — | — | — | — | — | 1 | 2 | — |
| 13 : 12 1/2 | 1 | 2 | 3 | 5 | 10 | 12 | 15 | — | — | — | — | 1 | 2 | — |
| 13 : 13 1/2 | 1 | 2 | 3 | 5 | 10 | 12 | 15 | — | — | — | — | 1 | 2 | — |
| 13 1/2 | 1 | 2 | 3 | 5 | 10 | 12 | 15 | — | — | — | — | 1 | — | — |
| 13 1/2 : 10 1/2 | — | — | 3 | 5 | 10 | — | — | — | — | — | — | — | — | — |
| 13 1/2 : 11 1/2 | — | 2 | 3 | 5 | — | — | — | — | — | — | — | 1 | — | — |
| 13 1/2 : 13 | — | — | 3 | 5 | — | — | 15 | — | — | — | — | — | — | — |

NOTE 6. Comparing this table with Kohl's it will be observed that the compounds in this case are carried to a difference of $\frac{1}{2}$ a perforation and that no distinction is made with regard to paper old or late. The exception in Kohl between $9\frac{1}{4}$ and $9\frac{3}{4}$ is made because the machines were different and compounds are disregarded when resulting from line variations of the same machine and only those distinguished when made by different machines. This latter table is, therefore, to be considered out of date.

NOTE 7. **Errors in Printing.** The issue of 1890 was in commission for 10 years and the number of essays and errors is very great. The best authorities are not able to differentiate between them, and as their delivery for use in other than correct condition was forbidden by the department all that can be said is that the control was very lax and sadly in need of reconstruction. They need not worry our collectors however, as they will not be found except in the cases of poor centering. Selecting from the long list given by Kropf, Kohl (1912) mentions the following as having done postal service. (See also Kropf P. 76).

| | | |
|--|-------|-------|
| 1K. numerals shifted toward top or bottom | 1.25 | .25 |
| 1K. without numerals in the corners ($10\frac{1}{2}:11\frac{1}{2}$) | — | — |
| 2K. without numerals in the corners (10) | — | — |
| 2K. without numerals in the upper and lower corners | — | 15.00 |
| 2K. with numerals shifted toward the top | 3.75 | — |
| 3K. without numerals in the corners (10) | 25.00 | — |
| 3K. numerals on the back | 12.50 | — |
| 3K. numerals in upper left corner only | — | — |
| 3K. numerals in upper right corner only | — | — |
| 3K. numerals shifted toward top or bottom | — | 3.75 |
| 3K. with numerals shifted toward the left | — | — |
| 5K. without numerals in the corners ($11\frac{1}{2}$) | — | 25.00 |
| 5K. numerals in upper left corner only, or upper and lower left corners only, or upper and lower right corners | 12.50 | — |
| 5K. numerals on the back | 12.50 | 18.75 |
| 5K. with numerals shifted toward the top | — | 1.25 |
| 10K. without numerals in the corners ($10\frac{1}{2}$) | — | 7.50 |
| 10K. without numerals in right lower corner | 10.00 | — |
| 10K. numerals on the back | — | — |
| 10K. numerals shifted toward the right at the top or toward the left at the bottom | 12.50 | — |
| 10K. numerals, double impression | — | — |
| 12K. without numerals in corners ($11\frac{1}{2}$) | — | — |
| 12K. without numerals, but printed on the back | 25.00 | — |
| 12K. without numerals in lower right corner | 12.50 | — |
| 12K. numerals shifted toward the bottom | — | 2.50 |
| 15K. without numerals in the corners | — | — |
| 15K. numerals only in lower left or right corner | — | — |
| 15K. without numerals in upper left corner | — | — |
| 15K. numerals shifted toward the right or left at top or bottom | 1.85 | 2.50 |
| 20K. without numerals in the corners ($10\frac{1}{2}$) | — | — |
| 20K. without numerals in the lower left corner | — | — |
| 24K. without numerals in the corners ($10\frac{1}{2}$) | — | — |
| 24K. numerals shifted toward the bottom | — | — |
| 30K. without numerals in the corners ($10\frac{1}{2}:11\frac{1}{2}$) | — | — |
| 30K. numerals shifted toward the top | — | — |
| 50K. without numerals in the corners ($10\frac{1}{2}:11\frac{1}{2}$) | — | — |
| 50K. numerals shifted toward the bottom | — | — |

(To be continued.)



Published the 15th day of each month

J. KLEMMANN, Jr., Editor.

CLIFTON A. HOWES, Special Contributing Editor.

JOHN A. KLEMMANN, Managing Editor.

Staff Writers.

CHARLES LATHROP PACK

VICTOR M. BERTHOLD

J. MURRAY BARTELS

DR. CARROLL CHASE

A. E. OWEN

W. B. SPRAGUE

B. W. H. POOLE

SUBSCRIPTION \$1.00 A YEAR, SINGLE NUMBERS 10c.

Advertising Rates

| | 1 mo. | 3 mos. | 6 mos. | 9 mos. | 12 mos. |
|--------------|--------|--------|--------|---------|---------|
| 1 inch | \$1.50 | \$4.00 | \$7.75 | \$11.50 | \$15.00 |
| ¼ p. | 5.00 | 13.50 | 26.25 | 38.00 | 50.00 |
| ½ p. | 8.50 | 23.00 | 44.50 | 65.00 | 85.00 |
| 1 page | 15.00 | 40.50 | 78.75 | 114.75 | 150.00 |

NASSAU STAMP CO., Publishers, 118 NASSAU ST., NEW YORK.

VOL. V, No. 7.

NEW YORK, JULY, 1915.

WHOLE No. 71.

EDITORIAL.

The A. P. S. Convention.

Before the next issue of The Gazette appears, the A. P. S. Convention will be a thing of the past. More than ordinary interest attaches to the Convention this year, because of its meeting in San Francisco during the Panama-Pacific Exposition affording the members a combination program hard to beat. The special program prepared by the Pacific Coast Society is printed on another page and is a sure index of what may be expected.

The N. P. S. Convention.

To those living in the east who are unable to go to the A. P. S. Convention at San Francisco, we would suggest that they attend the Convention of the National Philatelic Society in New York, full particulars of which are printed under our Society Notes. The program is an interesting one and we feel sure, with its many attractions, New York and vicinity can offer much to the visiting philatelists.

The Confederate States of America.

Under the above title we begin in this issue a history of the general issues by Mr. B. W. H. Poole.

The stamps of the Confederacy, like those of the U. S. have long been neglected which may be due to the lack of material for study which has been exceedingly hard to obtain.

We feel, however, that a careful study of this article will create renewed interest in these stamps and throw new light on many points hitherto obscure.

SHORT NOTES AND NEWS.

New South Wales—Error in Plating.

The publication committee of the Royal Philatelic Society, London, has just sent out a photograph to replace stamp # 34 on Illustration I in their publication, the Postage Stamps of New South Wales, by A. F. Basset Hull, published in 1911. This refers to the error in plating discovered by Mr. Charles Lathrop Pack and first announced in the PHILATELIC GAZETTE for April, 1915.

Telephone Postal Card.

The following clipping taken from the "Courier Crescent," a semi-weekly, published at Orrville, Wayne Co., Ohio, was sent to us by Mr. Howard C. Buttermore, calling attention to a Telephone Postal Card. The matter was taken up with the Post Office Department and we print both the clipping and the reply of Third Assistant Postmaster General Dockery in regard to it.

Clipping from the Courier Crescent.

"A contemplated innovation in the postal service is the issue of a postal card which will bear the telephone number of the addressee. When the postal card arrives at the post office of its destination, the postmaster will call up the addressee and read the message over the telephone, as is now done by the telegraph companies. Later the card is delivered in the usual manner. This plan will beat the special delivery service by a good margin."

Reply of Third Assistant Postmaster General Dockery.

"No steps have been taken by the Department looking to the issuance of a telephone postal card such as you describe. Such a card could not be employed when addressed to persons having no telephone, and would fail of its purpose in such cases. Aside from this objection, it could probably not be adopted without legislation by Congress."

Aeroplane Mail Service Data.

Mr. Gardner Teall calls our attention to the following aerial postal stations, established by the Post Office Department and not mentioned in the list published in the June GAZETTE, and which were authorized as temporary stations for the periods noted.

| POST OFFICE | DATE |
|----------------------------|---------------------------|
| | 1912 |
| San Diego, California. | April 6th and 7th. |
| Oakland, California. | February 17th to 25th. |
| Marietta, Ohio. | May 15th and 16th. |
| Chico, California. | May 3rd, 4th and 5th. |
| Evansville, Indiana. | June 6th, 7th and 8th. |
| Hamilton, Ohio. | July 12th and 13th. |
| Benton Harbor, Michigan. | July 17th and 18th. |
| Rockport, Indiana. | August 20th to 24th. |
| Portland, Oregon. | August 10th and 11th. |
| Boonville, Indiana. | August 28th to 31st. |
| Cedar Falls, Iowa. | September 5th and 6th. |
| McLeansboro, Illinois. | September 26th to 28th. |
| Bluffton, Indiana. | September 25th and 26th. |
| Springfield, Illinois. | October 4th to 12th. |
| Cuthbert, Georgia. | October 31 to November 2. |
| San Francisco, California. | November 24, 1912. |
| San Francisco, California. | December 25th to 29th. |
| | 1913 |
| Santa Rosa, California. | May 17th and 18th. |
| Rutland, Vermont. | First week in September. |
| McLeansboro, Illinois. | September 4th to 6th. |
| Troy, Alabama. | November 3d to 8th. |
| Helena, Montana. | September 22d to 27th. |

New England Stamp Co.

Mr. A. W. Batchelder and Mr. W. B. Putney, both of the New England Stamp Co., have sold out their interest and retire from the firm. We understand that the Scott Stamp & Coin Co. are the purchasers.

Mr. Batchelder has been in ill health for some time and therefore, not able to give the attention to business he wished.

We are informed business will be continued with a resident manager appointed by the Scott Stamp & Coin Co., who are the largest holders of stock in the New England Stamp Co.

German-Polen.

Post and Telegraph Offices have been established in Russian Poland in the towns of Kalisch, Bendzin, Czenstochan, Kolo, Konin, Lodz, Pabianice, Sieradz and Wloclawek.

The main post-office is in Kalisch. These offices effect the circulation of letters etc. among employees and their families in Poland. Private correspondence between Poland and Germany has not been allowed yet.

The issued values are 3, 5, 10, 20, 40pf. and postal cards 5pf and return post as 5 + 5. For collectors and dealers these stamps can be purchased at Berlin at 2 Konigstr. 61. The sale was begun May 12th.

Dominican Republic.

The issue of postage stamps of the denominations 1, 2, 5, 10 and 20 centavos placed in circulation in accordance with a decree of January 2, 1915, and those made good by restamping in compliance with the provisions of decree of February 18, 1915 having become exhausted, the President of the Republic has ordered the following denominations of the old issue restamped for circulation—

| | |
|----------|---------|
| 1c..... | 200,000 |
| 2c..... | 60,000 |
| 5c..... | 175,000 |
| 10c..... | 100,000 |
| 20c..... | 5,000 |

—Pan American Union Bulletin.

UNITED STATES LOCAL STAMPS.**A Concise History and Memoranda.**

COMPILED BY HENRY C. NEEDHAM.

(Continued).

ALLEN'S CITY DISPATCH.
Chicago.

Edward Allen who at one time had been connected with an old local post in New York, opened an office on the third floor of No. 125 South Clark Street, Chicago, in 1882, advertising that he would deliver letters, circulars, &c., within the city limits, and claiming that he could make better time than the regular city mail carriers. He occupied three rooms, one of which was used as an office, one for sorting and stamping envelopes, newspapers and other matter, the other with pigeon holes as a local post office. He placed mail boxes at convenient points throughout the city, from which mail was collected at regular intervals; he soon employed thirty-three uniformed carriers. Mr. Allen devoted his entire time to the business, and it was quite successful from the outset; he had stamps lithographed and printed, as more particularly enumerated below. It will be noticed that no value is expressed on these stamps, the reason being that his rate varied with the volume of business intrusted to him. We have heard of no instance in which the stamps were sold at less than 75 cents per thousand, assuming, of course, that circulars or other matter were to be delivered. The Stamp Collectors Monthly was delivered to Chicago subscribers at the rate of one dollar per thousand. It is undoubtedly a fact that the stamps were not issued at the instigation of the philatelic fraternity, but were

printed for legitimate use; the idea of the use of stamps evidently having been brought to Chicago by Mr. Allen from his early experience as an employee of one of the Eastern local posts. Later Mr. Allen sold his stamps, cancelled, to local dealers at the rate of 50 cents per hundred. The cancellation used was a rubber hand stamp, usually with red or violet ink. This hand stamp was an oval, date in centre, Allen's City Dispatch above, and 125 Clark Street at bottom; to the right of this cancellation, and usually hitting the stamp, was an eagle with wings full spread.

Early in 1883 the Post Office authorities suppressed the Post. In August of that year Mr. Allen sold the remainder of his stamps, it is said, to Messrs. C. H. Mekeel & Company.

An interesting account of this Post will be found in the Philatelic Journal of America, April, 1885.

During the month of May, 1883, Mr. J. K. Tiffany of St. Louis, Missouri, received an interesting communication in reference to the troubles of the Post from J. E. Stuart, Post Office Inspector, in which it is stated that the Post ceased to do business on February 5th, 1883.



ALLEN'S CITY DISPATCH.

One Type Only. 1882.
Perf. 10x10.

No value, Pink.

No value, Black.

No value, Red on Yellow.

No value, Deep Purple.

Imperf.

No value, Red on Yellow.

AMERICAN BANK NOTE COMPANY.

New York.

This is one of the largest companies in the world engaged in the business of engraving and printing stamps, bank notes, bonds, stock certificates, &c. Most of the concerns earlier engaged in the printing of stamps, &c., were consolidated with or bought out by this company. It is claimed that the stamp, Type I, mentioned below, was issued and used in the delivery of its circular letters; as to this we have no knowledge, and we are inclined to believe that the stamp is more of an advertisement than otherwise.



AMERICAN BANK NOTE COMPANY.

Type I.

No value, Indian red on yellowish white bond paper.

Type II.

5c coupon stamp, deep blue on bluish pelure paper.

(To be continued.)

NEW PLATE NUMBERS.

Through the courtesy of Mr. J. E. Ralph, Director of the Bureau of Engraving and Printing, we print herewith the full list of plate numbers to July 1, 1915.

| No. | Den. | Class | No. | Den. | Class |
|------|------|----------|------|------|----------|
| 7420 | 2c | Ordinary | 7457 | 2c | Ordinary |
| 7421 | 2c | " | 7458 | 2c | " |
| 7422 | 2c | " | 7459 | 2c | " |
| 7423 | 2c | " | 7460 | 2c | " |
| 7424 | 2c | " | 7461 | 2c | " |
| 7425 | 2c | " | 7462 | 2c | " |
| 7426 | 2c | " | 7463 | 2c | " |
| 7427 | 2c | " | 7464 | 1c | " |
| 7428 | 2c | " | 7465 | 2c | " |
| 7429 | 2c | " | 7466 | 2c | " |
| 7430 | 2c | " | 7467 | 2c | " |
| 7431 | 2c | " | 7468 | 2c | " |
| 7432 | 2c | " | 7469 | 2c | " |
| 7433 | 1c | " | 7470 | 2c | " |
| 7434 | 1c | " | 7471 | 2c | " |
| 7435 | 5c | " | 7472 | 2c | " |
| 7436 | 5c | " | 7473 | 2c | " |
| 7437 | 2c | " | 7474 | 1c | Book |
| 7438 | 2c | " | 7475 | 2c | Ordinary |
| 7439 | 4c | " | 7476 | 2c | " |
| 7440 | 4c | " | 7477 | 2c | " |
| 7441 | 3c | " | 7478 | 2c | " |
| 7442 | 3c | " | 7479 | 2c | " |
| 7443 | 2c | " | 7480 | 1c | Book |
| 7444 | 2c | " | 7481 | 2c | Ordinary |
| 7445 | 2c | " | 7482 | 2c | " |
| 7446 | 2c | " | 7483 | 2c | " |
| 7447 | 2c | " | 7484 | 1c | Book |
| 7448 | 2c | " | 7485 | 1c | Ordinary |
| 7449 | 1c | Book | 7486 | 2c | " |
| 7450 | 2c | Ordinary | 7487 | 2c | " |
| 7451 | 2c | " | 7488 | 2c | " |
| 7452 | 4c | " | 7489 | 2c | " |
| 7453 | 4c | " | 7490 | 2c | " |
| 7454 | 2c | " | 7491 | 2c | " |
| 7455 | 2c | " | 7492 | 2c | " |
| 7456 | 2c | " | 7493 | 1c | " |

COMMUNICATIONS.

Falsification of the stamps of 20 Pesos Green, Issue 1891 of the Argentine Republic.

Editor, Philatelic Gazette:

I received No. 3, Vol. V of your interesting Gazette, and I thank you for the attention given to my description of the "doctored" 20 Pesos green, 1891, Argentine Republic.

I should be very much obliged to you if you would publish also the following lines, respecting the same topic:—

"I beg to point out that Mr. Charles Lathrop Pack's supposition that the fraud might possibly not extend as far as I have feared, is unfortunately rather optimistic, and calls for an answer in the interests of all collectors seeking genuineness. In reality, the number of thus cleaned copies seems to be enormous, and I alone have seen at least 100 of them during the last few months:

this without searching specially for them. All these were in the hands of collectors and dealers, most of which would not feel, or admit the slightest doubt with regard to the authenticity of same.

Two best known monthly bulletins of Paris and Berlin, have recently made very advantageous offers of the same stamp, which means that LOTS of them have been offered to the Berlin and Paris dealers at low prices. It seems to be very curious that such could be the case whilst dealing with such a very rare stamp, and the coincidence is so singular that I must confess there is not much doubt in my mind that they are doctored copies, the word MUESTRA having been cleaned away like the great majority of those we meet with here.

I hasten to observe that the dealers referred to undoubtedly have acted in the best faith, but this does not bar the fact that they may possibly have been imposed upon. I intend to forward to Mr. Pack one cleaned pair, in order to convince him with what remarkable dexterity this work has been carried out, and how easy it is to be deceived by it.

For further explanation, I may add that several entire MUESTRA (Specimen) sheets of this stamp have recently been offered for sale by an ex-employee of the post office: he had apparently come across them somewhere in an official or private post archive. Each sheet contains 100 copies, and we can now buy blocks of four of this MUESTRA stamp for 10 to 20 pesos (5 to 10 dollars). I presume that two or three sheets have been cleaned and realized, and possibly the "artist" may still be devoting himself to this lucrative work. At any rate, I am convinced that a very great number of cleaned copies are in circulation, and that they are very dangerous. *Collectors cannot be too strongly warned to use the utmost prudence when dealing with an acquisition of this kind.* The salvation of this interesting and rare stamp can only be effected by the exercising of this prudence, and giving the case large publicity.

I now believe that scraper and magnifying glass were or are not the only instruments employed by that perfect "etching" artist, but that he also knows of the utility of acids or other chemical matter, which are able to help him in clearing away as perfectly as he does, a very heavily printed word like MUESTRA. The facts, that the gum is very cleanly washed away from all frauded copies, and that the paper seems to be more absorbent in the oblong spot which was that of the word MUESTRA, seem to confirm this opinion.

Finally, I wish to state that the 1 Peso and 5 Pesos Argentine 1890-91, and the 1, 5, 10 and 20 Pesos Argentine 1894 are also circulating in the same defrauded condition. The 1 Peso of 1891 is very dangerous, but the 5 Pesos less so; the 1-20 Pesos of 1895 are not dangerous, because it was not possible for the forger to clean away every trace of the red ink used for the overprinting of the word MUESTRA on those stamps.

Buenos Aires, 28th May, 1915.

W. LOESCHER."

SOCIETY NOTES.

American Philatelic Society.

The Thirtieth Annual Convention of this Society for the election of Directors and the transaction of such other business as may be legally brought before it will be convened at San Francisco, California, on Tuesday, August 10th, 1915, at 10:30 o'clock A. M., and upon succeeding days until such business shall have been disposed of.

The Convention Headquarters and place of meeting will be at Hotel Stewart, No. 353 Geary Street, San Francisco, California.

The Convention will be called to order and proceed to business under the direction of the senior Director present.

The Committee on Credentials is as follows:—

- Dr. J. M. Holt, Chairman, of San Francisco, Calif.
- A. H. Weber, of Berkeley, Calif.
- F. L. Stolz, of San Francisco, Calif.
- W. C. Michaels, of Kansas City, Mo.
- A. W. Batchelder, of Boston, Mass.

Ballots and proxies may be sent to Dr. J. M. Holt, Chairman, addressed care of Hotel Stewart, No. 353 Geary Street, San Francisco, Calif.

The Committee on Arrangements for the Convention will be as follows:

H. B. Phillips, Chairman, of Berkeley, Calif.
 H. C. Marcus, of San Francisco, Calif.
 Louis Lazarus, of Oakland, Calif.
 Frank C. Marcus, of Palo Alto, Calif.
 E. H. Richardson, of San Mateo, Calif.

CHAS. A. COOLIDGE, President.

OFFICIAL BALLOT—

C. A. Howes, Mass. (President)
 H. H. Wilson, N. Y. (Vice President)
 Wm. B. Sprague, N. Y. (Vice President)
 Carroll Chase, N. Y. (Vice President)
 Baldwin Schlessinger, N. Y. (Vice President)
 *A. Hatfield, Jr., N. Y. (Vice President)
 Wm. Homan, N. Y. (Vice President)
 Wm. E. Ault, Indiana (Secretary)
 L. H. Kjellstedt, Pa. (Int. Secy.)
 C. F. Heyerman, Mich. (Treasurer)
 H. B. Phillips, Calif. (Director-at-Large)
 H. C. Barr, N. Y. (Director-at-Large)
 W. H. Barnum, Ohio (Director-at-Large)
 E. R. Aldrich, Minn. (Director-at-Large)

*Withdrawn.

OFFICIAL PROGRAM.

TUESDAY, AUGUST 10

10:00 A. M.—Opening Business Session.

1:00 P. M.—Trolley Excursion, Alameda County. Take Key Route Boat, Ferry Building, foot of Market Street. Boat leaves at 1 P. M.

7:00 P. M.—Stamp Exhibition and Mart at the Stewart Hotel.

WEDNESDAY, AUGUST 11

10:00 A. M.—Business Session.

12:00 M.—Official Photograph will be taken at the north front of Auditorium Building.

2:00 P. M.—Bay Excursion. Leaves Howard St. Wharf on Crowley Boat.

7:00 P. M.—Traditional Banquet at the Clift Hotel, 495 Geary Street, southeast corner of Geary and Taylor Streets.

THURSDAY, AUGUST 12

10:00 A. M.—Final Business Meeting. All remainder of the day and evening at the Exposition Grounds. This is "Official Day" of the American Philatelic Society. Exercises at 2:30 P. M. in the California Building.

OFFICIAL HEADQUARTERS—

The Stewart Hotel, one of the most popular hostelries in San Francisco has been chosen as the official headquarters. This Hotel is situated in the heart of the City, convenient to the shopping, theatre and cafe districts. There are 350 rooms, 250 connecting bath rooms, accommodations, either on the American or the European plan. Rates are very reasonable.

The Stewart Hotel is located on Geary Street, just a few steps from Union Square and Powell Street. The Geary Street line (Municipal Railway) passes the door direct from the Union Ferry Depot. From the Third and Townsend Depot, the Third Street cars transfer to the Geary Street line, which runs cars direct to the Exposition Grounds. It is advisable to make reservations before arrival.

National Philatelic Society.**Third Annual Convention, New York, N. Y., July 22, 23, 24, 1915.****OFFICIAL PROGRAM.**

Thursday, July 22nd, 1915.

7.45 P. M.—Opening Social and Business Session in large Ball Room, Aschenbroedel Hall, 144 East 86th St. Prominent philatelists will address the Convention.

9.30 P. M.—Flash Light Picture.

Friday, July 23rd, 1915.

12.45 M.—Luncheon at Nassau Cafeteria, 75-77 Nassau Street.

1.30 P. M.—Second Business Session.

7.45 P. M.—Third Business Session at Aschenbroedel Hall, 144 East 86th Street. To be followed by Club Auction of about 100 lots of stamps donated by the members for the benefit of the recruiting work of the Society.

Saturday, July 24th, 1915.

12.30 M.—Luncheon at the Nassau Cafeteria, 75-77 Nassau St.

1.00 P. M.—Final Business Session.

6.00 P. M.—All aboard for Coney Island and Luna Park as guests of the New York Philatelic Exchange Society, Branch No. 3. Two special cars have been chartered and will leave Brooklyn Bridge at 6 P. M. (All meet at Police Signal Station N. Y. end of Brooklyn Bridge.) Headquarters in Luna Park, in front of the office of Luna Park.

International Society of Postage Stamp Dealers, Paris.

Under this denomination a Society has been constituted in Paris on June 18th, 1915, which has its seat in that town at the President's residence, 16, Avenue de l'Opera.

The following officers have been appointed:

President, M. Lemaire.

Vice-Presidents, Mess. Champion and Vervelle.

Secretary, M. R. Poulain.

Sub Secretary, M. Marquetel.

Treasurer, M. Lerrou.

Manager of the Bulletin, M. Lemierre.

Superintendent of the Circulation of Stamps, M. Roland.

Members of foundation, Mess. Chevillard, Delacourcelle, Farges, Gilbert, A. O. Marimian, Moreau, Nicolaides, Perron, Roumet, Yvert et Tellier.

The aim of this Society is:

- 1—To establish friendly relations between the members and to facilitate their business connection;
- 2—To bring forward motions, to study and to work up means fit for developing the stamp business;
- 3—To protect the interests of its members and to help them as far as possible by giving information, references and useful advice;
- 4—To fight against forgers and their accomplices.

In order to attain this aim, the Society will hold monthly sessions, will publish a journal (Bulletin), establish a library, attend to the circulation of stamps and expertize stamps of the Society.

There will be admitted to membership anybody who has been dealing regularly in postage and fiscal stamps and philatelic accessories for two years, at least, and who is presented by two sponsors. Ladies doing business in their own name are eligible. (No member of the International Society of Berlin will be accepted should he not have given notice to the same).

The entrance fee is frs. 6.—and the annual dues 12 frs.

The Regulations are in the press and will be forwarded on application.

AUCTION REPORT.

J. C. Morgenthau & Co. 98th Sale.

| | | |
|---------|--|--------|
| Lot No. | | |
| 58 | Austria, 1858, 2kr. orange (40), used, | 7.50 |
| 112 | Hungary, 1871, Litho. 3kr. green (3), unused, o. g. | 10.25 |
| 193 | Belgium, 1861, 40c carmine rose (18), unused, o. g. | 8.75 |
| 243 | — 1849, 10c brown (2), horizontal pair, used, | 4.10 |
| 245 | — — 20c blue (4), horizontal pair, used, | 3.35 |
| 246 | — 1850, 10c brown (6), horizontal pair, used, | 4.00 |
| 254 | — 1875, 5fr yel. brown (131, S 39), "Liege" cancellation, | 7.25 |
| 345 | Denmark, 1853, 16s gray lilac (10), horizontal pair, used, | 5.25 |
| 396 | Iceland, 1902-3, Perf. 12½, without dash (—) between "02" and "03", 6 ore gray, Red surcharge, o. g., | 8.75 |
| 397 | — — 25a blue and brown without dash, o. g., | 8.75 |
| 424 | France, 1849, 1fr orange brown (14, S 9a), unused, | 95.00 |
| 482 | — 1849, 15c deep green (3), horizontal pair, used, | 13.25 |
| 488 | — — 1fr deep carmine brown (16), horizontal strip of 3, used, | 10.50 |
| 489 | — — 1fr orange vermilion (13), lightly cancelled, | 141.00 |
| 491 | — 1853, 1fr deep carmine (59), horizontal pair, used, | 18.25 |
| 844 | Baden, 1853, 3kr blue (10), unused, | 15.25 |
| 897 | Bergedorf, 1861, ½sch violet (1), unused, o. g., | 55.00 |
| 902 | Bremen, 1855, 3gr, vertical laid (2), type III, o. g., | 9.25 |
| 941 | Hamburg, 1859, ½sch black (1), horizontal pair, o. g., | 10.50 |
| 942 | — — ½sch black (1), horizontal pair, o. g., | 8.50 |
| 951 | — — 9s pale yellow (10), horizontal pair, o. g., | 13.60 |
| 1008 | Mecklenburg Schwerin, 1856, 3s orange yellow (3), horizontal pair, o. g., | 6.25 |
| 1029 | Oldenburg, 1852, 1/15th rose type B (8), o. g., | 105.00 |
| 1030 | — — 1/10th yellow (11), o. g., | 105.00 |
| 1031 | — 1855, ½sgr green (13, S 4), full o. g., | 20.00 |
| 1035 | — 1859, 1gr blue (15), o. g., | 26.00 |
| 1037 | — — 2gr rose (18, S 7), o. g., | 40.50 |
| 1040 | — — 3gr yellow (20), pale shade, o. g., | 42.00 |
| 1051 | — 1861, 2gr red (31, S 14), unused, | 18.25 |
| 1077 | Saxony, 1850, 3pf pale red (1), full o. g., | 136.00 |
| 1158 | Wurtemberg, 1858, 1kr brown (21), o. g., | 9.50 |
| 1163 | — — 9kr. carmine (28), o. g., | 48.50 |
| 1164 | — — 18kr. blue (29, S 18), o. g., | 21.25 |
| 1185 | — 1863, 18kr. orange (59, S 40), o. g., | 10.25 |
| 1202 | — 1873, 70kr. purple (84, S 53a), o. g., | 27.00 |
| 1203 | — — 70kr. red violet (85, S 53), unused, | 29.00 |
| 1235 | Bavaria, 1850, 18kr. yellow (19), horizontal pair, used, | 10.25 |
| 1240 | — 1867, 18kr. brick red (50), horizontal pair, used, | 16.00 |
| 1250 | Bremen, 1867, Perf. 13, 5gr. rose (20), used, | 12.25 |
| 1252 | — — 5sgr. yellow green (24, S 15a), used, | 10.75 |
| 1262 | Brunswick, 1861, ½sgr. green (15, S 11), horizontal pair, used, | 12.50 |
| 1266 | — 1864, Perce en arc ½sgr. black (22, S 13), used, | 39.50 |
| 1268 | — — 2sgr. blue (26, S 16), used, | 10.00 |
| 1294 | Hanover, 1864, Perce en arc ½gr black, rose gum, (36, S 26a), used, | 13.75 |
| 1315 | Oldenburg, 1859, 1gr gray blue (16), horizontal pair, used, | 12.25 |
| 1317 | — — 2gr rose (18), used, | 34.00 |
| 1321 | — 1861, ¼ gr. orange yellow (21, S 9), used, | 66.00 |
| 1324 | — — ½gr. brown (26, S 12), used, | 33.00 |
| 1326 | — — 1gr. deep blue (28), used, | 13.25 |
| 1328 | — — 2gr. red (31, S 14), used, | 21.50 |
| 1331 | — — 3gr. pale yellow (33, S 15), used, | 33.50 |
| 1339 | Saxony, 1850, 3pf brownish red (3), used, | 90.00 |
| 1373 | Wurtemberg, 1856, 18kr. blue (19, S 12), horizontal pair, used, | 53.00 |
| 1381 | — 1861, 18kr. blue (44), darker shade, used, | 19.00 |
| 1389 | — 1873, 70kr. purple (84, S 53a), used, | 50.50 |

J. C. Morgenthau & Co. 99th Sale.

| Lot No. | | |
|---------|---|--------|
| 2 | Holland, 1852, 5c blue (2), o. g., | 6.50 |
| 3 | — — 5c deep blue (3, S 1c), o. g., | 6.60 |
| 6 | — — 10c rose carmine (6), light shade, o. g., | 5.50 |
| 7 | — — 10c rose (6), horizontal pair, o. g., | 12.60 |
| 8 | — — 15c orange yellow (7, S 3), o. g., | 5.70 |
| 11 | — — 15c orange yellow (7), horizontal pair, o. g., | 13.80 |
| 75 | — — 15c orange (7), horizontal pair, used, | 4.35 |
| 196 | Parma, 1854, 5c pale yellow (10, S 6), o. g., | 32.00 |
| 198 | — — 15c red (13, S 7), o. g., | 23.00 |
| 224 | Sardinia, 1853, 5c blue green (8, S 4), horizontal pair, o. g., | 12.00 |
| 242 | Sicily, 1859, 5g. deep carmine red (11), o. g., | 10.50 |
| 257 | Tuscany, 1851, 2s brick red on blue (6), o. g., | 90.00 |
| 264 | — — 60cr. brick red on blue (23), o. g., | 131.00 |
| 267 | — 1853, 1s yellow buff (25), o. g., | 42.50 |
| 274 | — — 9cr. purple brown (33), o. g., | 70.00 |
| 305 | Naples, 1860, ½t deep blue (17b, S 9), used on original, | 47.00 |
| 307 | — — ½t pale blue (17c), used, | 32.50 |
| 320 | Parma, 1854, 5c orange yellow (11), horizontal pair, used, | 9.25 |
| 344 | Sardinia, 1853, 40c rose (10), horizontal pair, used, | 11.50 |
| 345 | — 1854, 5c yellow green (12), horizontal pair, used, | 8.00 |
| 360 | Sicily, 1859, 10gr indigo (16), horizontal pair, used, | 8.10 |
| 386 | Tuscany, 1853, 9cr. purple brown (33, S 23), used, | 20.50 |
| 404 | Luxemburg, 1852, 10c black (1), o. g., | 10.10 |
| 406 | — — 10c gray black (2), o. g., | 10.50 |
| 408 | — — 1sgr. deep rose (4), o. g., | 10.50 |
| 410 | — — 1sgr. dull rose (4), o. g., | 11.50 |
| 440 | — — 10c black (1), horizontal pair, used, | 5.10 |
| 441 | — — 10c gray black (2), horizontal pair, used, | 4.10 |

I hold one of the

Finest Stocks

of rare and medium stamps in Europe.

My Specialities are

High Class Selections

of stamps of all countries and filling of want lists a/c to any catalogue. Owing to my systematic and continual fresh purchases, serious collectors have a good opportunity of acquiring "hard to get" stamps at moderate prices.

FOR SPECIALISTS,

Interesting items in great variety.

W. HOUTZAMER,

368, Strand,

London, England.

(Formerly of The Hague, Holland.)

(Member of the Chicago Phil. Society, and of the American Phil. Society.)

LIBERIA.

| | |
|-------------------------|--------|
| *1862 6ct. red | \$2.50 |
| * 12cts. blue | 2.00 |
| * 24cts. green | 2.00 |
| *1866-9 6c light red | 1.00 |
| * 12c light blue | 1.50 |
| * 24c light yell. green | .50 |
| *1880 12c. yellow | .25 |
| * 24c. rose red | .25 |
| *1882 8c. blue | .30 |
| * 16c. red | .75 |
| *1885 16c. yellow | .25 |
| * 32c. deep blue | .50 |

and nearly all others in stock, Postage and Officials.

NETHERLANDS.

Complete, used and in mint condition, nearly all varieties of perforation and type in stock, and many great varieties of these. Send your Want Lists.

OLD GERMAN STATES.

A splendid lot on hand in used and unused condition. Prices moderate.

PHILIPPINES.

1854-55. Several copies on hand. Prices on application.

| | |
|---------------------|-------|
| *1859 5c. vermilion | 1.25 |
| * 10c. rose | 1.00 |
| *1861 5c. vermilion | 1.25 |
| * 5c. dull red | 1.65 |
| *1863 5c. vermilion | .75 |
| * 10c. carmine | 2.00 |
| * 1R. violet | 20.00 |
| * 2R. blue | 15.00 |

A fine lot of Philippines in singles, pairs and blocks on hand,—all in superb condition.

PORTUGUESE COLONIES.

A splendid stock of these used and unused. Want Lists solicited.

U. S. STAMPS.

We have recently remounted nearly all of our fine U. S. (as well as the foreign) approval selections in which are included all of our choicest stock. These we will submit to responsible collectors on approval. Read the descriptions of the following and write for what you would like to see. This incurs no obligations to buy. ★ means unused stamps only.

- ★ No. 1 1847-1800, finest condition only, stamps from \$2 to about \$30. General issues.
- ★ No. 2 1847-70, finest condition, stamps from 25c to \$4.
- ★ No. 3 1847-88, Liberal discounts. Good grade, 50% or more off catalogue.
- ★ No. 4 **Special Bargains.** Including stamps with trifling imperfections. About 55-85% discount.
- ★ No. 5 1870-82, Fine copies, shades, etc., all the different printings.
- ★ Nos. 7-13 1890-1902, A very attractive book of each issue in many shades.
- ★ No. 15 **Departments,** finest grade.
- ★ No. 16 **Postage Due,** splendid shades.
- ★ No. 20 **General Issues.** Fine used copies, 10c-\$2 each.
- No. 20A **General issues,** odd cancellations, nice lot. Getting popular.
- No. 21 **Same.** Fine copies of scarce stamps. From \$1 to \$20 each.
- No. 22 1847-1908, Special bargains at very substantial discounts, some have slight imperfections.
- No. 23 1870-82, the different printings, selected copies, carefully marked.
- Nos. 28-40 are in **Blocks of 4.**
- ★ No. 28 1851-88 a few nice things left.
- ★ No. 30 1890. Many fine shades.
- ★ No. 32 1894, Good line of shades.
- ★ No. 33 1895-98. Very popular.
- ★ No. 35 1902-07. Grand lot of shades.
- ★ No. 36A 1908. Strong in shades.
- ★ Nos. 38, 39, **Postage Due,** in shades.
- ★ No. 45 **Revenues,** old issues, \$2 up.
- ★ No. 47 **Same 1898-1902,** blocks in shades.
- No. 48 **Telegraph stamps.**
- ★ Nos. 49 to 63 U. S. **Envelopes,** cut square. A book of each issue.
- No. 64 **Plate Proofs,** card or India.
- No. 67 **Confederate States.** General issues. Fine lot incl. shades and blocks.
- No. 81 **Philippines,** 1854-88. Grand lot.
- ★ No. 87 **Philippines,** U. S. Issues only.
- ★ No. 93 U. S. **Colonies.** For album spaces. One fine copy of each.

For full list of U. S. and Foreign Selections see our **Pink List.** It describes over 200 different books. Sent free.

J. M. BARTELS CO.

99 Nassau St., New York

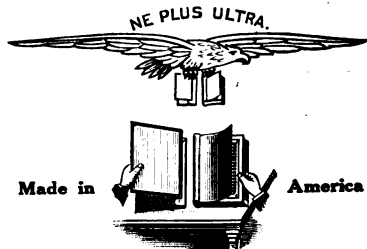

Interchangeable Leaves

BLANK ALBUMS - \$4.00 and up
STOCK BOOKS - \$2.00 and up

Used by the foremost Collectors and Dealers
 Complete price list free on request



"Ne Plus Ultra" Watermark Revealer
 Price 50c. Postage 10c. extra

All "Ne Plus Ultra" supplies manufactured exclusively by
SCOTT STAMP & COIN CO.
 127 Madison Ave. New York City

100th SALE.

July 27th & 28th, 1915

Europe Part III.

Roumania to Turkey,
 Dom. Rep., Egypt, Hayti,
 Liberia, New Republic.

Catalogue mailed free on request.

J. C. Morgenthau & Co.

87 Nassau St., New York

Confederates

Locals and Carriers

What have you to offer?

Send at your lowest cash price.

JOHN A. KLEMANN

118 Nassau St. New York

THE PHILATELIC GAZETTE

PUBLISHED MONTHLY FOR STAMP COLLECTORS

VOL. V, No. 8.

NEW YORK, AUGUST, 1915.

WHOLE No. 72.

COPYRIGHT, 1915, BY THE NASSAU STAMP CO.

The United States Government Collection of Postage Stamps.

BY JOSEPH B. LEAVY

Philatelist, U. S. National Museum.

(Continued.)

ARGENTINE REPUBLIC

- 1858, 5c red, 10c green, 15c blue.
1861, 5c red, 10c green, 15c blue.
1862, 5c rose.
1864-67, watermarked R. A. in italics, perforated 11½, 5c brown rose, 5c lake, 10c green, 15c blue.
1867-68, groundwork of horizontal lines, 15c blue; groundwork of crossed lines, 5c vermilion, 10c green, 10c pale green.
1873, 1c purple, 1c deep violet, 4c brown, 4c red brown, 30c orange, 60c black, 90c blue.
1876-77, rouletted, 8c lake.
1878, rouletted, 16c green, 20c blue, 24c blue.
1877-80, perforated 12, 2c yellow green, 8c lake (muestra), 25c lake.
1882, ½ on 5c vermilion, ½ on 5c vermilion perforated in centre.
1884, engraved, 1c rose red.
1887, 24c blue.
1888, ½c blue, 2c yellow green, 3c blue green, 5c carmine, type II, 5c rose carmine, type II, 6c red, 10c brown, 10c pale brown, 15c orange, 30c chocolate, 30c brown, 40c slate, 50c blue.
1888-89, ½c ultramarine, 3c blue green, 6c blue black, 12c blue, 20c green, all overprinted muestra.
1890, ¼c green, 2c violet, 5c carmine, 5c rose carmine, 10c brown, 25c purple, 40c olive, 50c orange, 50c yellow, 60c black, all overprinted muestra.
1891, 8c carmine rose, 8c pale carmine rose, both overprinted muestra.
1891, 1 peso deep blue, 5 pesos ultramarine, 20 pesos green, all overprinted muestra; 1c brown re-engraved, overprinted muestra.
1892, 2c light blue, 5c dark blue.
1892-96, ½c dull blue, ½c ultramarine, 1c brown, 2c yellow green, 2c pale yellow green, 3c orange, 3c yellow orange, 5c carmine, 5c rose carmine, 10c carmine rose, 10c pale carmine rose, 12c deep blue, 16c gray, 24c gray brown, 50c blue green, 1 peso lake, 1 peso pale lake, 2 pesos dark green, 5 pesos dark blue, all overprinted muestra.
1896-98, 30c orange, 30c yellow orange, 80c dull violet, 1 peso 20c black.
1899, ½c yellow brown, 1c green, 2c slate, 5c carmine rose, 10c dark green, 12c dull blue, 12c pale blue, 16c orange, 20c claret, 24c violet, 30c rose, 50c bright blue, 1 peso blue & black, 5 pesos orange & black, 10 pesos green & black, 20 pesos red & black.

- 1901, 3c orange, 12c olive green, 15c sea green, 30c vermilion, 30c scarlet.
 1902, 5c deep blue.
 1903, 4c yellow, 6c black.
 1908-10, $\frac{1}{2}$ c violet, 1c brown buff, 2c chocolate, 3c green, 4c red violet, 5c carmine, 6c olive bistre, 10c gray green, 12c yellow buff, 1c apple green, 20c ultramarine, 24c red brown, 30c dull rose, 50c black, 1 peso slate blue & pink.
 1909, 12c dark blue.
 1910, $\frac{1}{2}$ c blue & gray blue, 1c blue green & black, 2c olive & gray, 3c green, 4c dark blue & green, 5c carmine, 10c yellow brown & black, 12c bright blue, 20c gray brown & black, 30c lilac & black, 24c orange brown & blue, 50c carmine & black, 1 peso bright blue, 5 pesos orange & violet, 10 pesos orange & black, 20 pesos deep blue & indigo.
 1911, 5c gray brown & black.
 1911, engraved, 5c vermilion, 12c deep blue; typographed, $\frac{1}{2}$ c violet, 1c brown ochre, 2c chocolate, 3c green, 4c brown violet, 10c gray green, 20c ultramarine, 24c red brown, 30c claret, 50c black.
 1912-14, watermarked network, 5c red, 12c deep blue, 1 peso dull blue & rose, 5 pesos slate & olive green, 10 pesos violet & blue, 20 pesos blue & claret.
 1913, official stamps for use in the various departments.
 Overprinted M. M., 1c ochre, 2c chocolate, 5c red, 12c deep blue.
 Overprinted M. G., 1c ochre, 2c chocolate, 5c red, 12c deep blue.
 Overprinted M. A., 1c ochre, 2c chocolate, 5c red, 12c deep blue.
 Overprinted M. H., 1c ochre, 2c chocolate, 5c red, 12c deep blue.
 Overprinted M. I., 1c ochre, 2c chocolate, 5c red, 12c deep blue.
 Overprinted M. J. I., 1c ochre, 2c chocolate, 5c red, 12c deep blue.
 Overprinted M. O. P., 1c ochre, 2c chocolate, 5c red, 12c deep blue.
 Overprinted M. R. C., 1c ochre, 2c chocolate, 5c red, 12c deep blue.

BUENOS AYRES

- 1858, 1 peso light brown, 2 pesos blue, 3 pesos green, 4 reales brown, all cancelled.
 1859, 1 (in) peso blue, 1 (to) pesos blue, both damaged.
 1860, 4 reales green on bluish, 1 peso blue, 2 pesos vermilion, last used.
 1862, 1 peso rose, 2 pesos blue, last used.

CORRIENTES

- 1856, 1 real blue, pen cancelled.
 1864-80, (3c) blue, (3c) green, (3c) yellow, (3c) lilac rose.

AUSTRIA

- 1850, hand-made paper, 3kr red, 5kr brown, 9kr blue, all used.
 Machine-made paper, 1kr yellow, 2kr black, 3kr red, 9kr blue, all used.
 REPRINTS. 1kr yellow, 2kr black, 3kr red, 6kr brown, 9kr blue, two shades of singles of each value, and still another shade of each value in a pair.
 1858, 2kr yellow, type II, used.
 REPRINTS of 1865, 2kr yellow, 3kr green, 3kr black, 5kr red, 10kr brown, 15kr blue, perforated 12.
 Of 1871, 2kr yellow, 3kr green, 3kr black, 5kr red, 10kr brown, 15kr blue, perforated $10\frac{1}{2}$.
 Of 1889, 2kr greenish yellow, 3kr green, 3kr black, all perforated 13.
 1861, 2kr yellow, 3kr green, 5kr red, 10kr brown, 15kr blue.
 REPRINTS of 1871, 2kr yellow, 3kr green, 5kr red, 10kr brown, 15kr blue, perforated $10\frac{1}{2}$.
 Of 1884, 3kr green, 5kr red, perforated 13.
 1863, 2kr yellow, 3kr green, 5kr rose, 10kr blue, perforated 14.
 1864, 2kr yellow, 3kr green, 5kr rose, 10kr blue, 15kr yellow brown, all perforated $9\frac{1}{2}$.
 REPRINTS of 1884, 2kr yellow, 5kr rose, 10kr blue, 15kr yellow brown, perforated 13.
 Of 1889, 2kr yellow, 3kr green, 15kr yellow brown, perforated $10\frac{1}{2}$, $11\frac{1}{2}$.

- 1867, 2kr yellow, 2kr orange (used), 3kr green, 5kr rose red, type II, 10kr blue, 15kr brown, 25kr gray lilac, all coarse beard; 2kr yellow, 2kr orange yellow, 3kr green, 5kr rose red, type III, 5kr rose red, type IV, 10kr blue, 10kr dark blue, 15kr brown, 15kr pale brown, 25kr lilac, all fine beard.
- 1877, 50kr light brown, coarse beard; 50kr pale red brown, fine beard.
- 1883, 2kr brown, 3kr green, 5kr rose, 10kr blue, 20kr gray, 50kr red lilac, perforated 9, 9½; 2kr brown, 3kr green, 5kr rose, 10kr blue, 20kr gray, 50kr lilac, perforated 10, 10½.
- 1890, 1kr dark gray, 1kr slate gray, 2kr light brown, 2kr brown, 3kr gray green, 3kr pale gray green, 5kr rose, 10kr ultramarine, 12kr claret, 12kr pale claret, 15kr lilac, 15kr pale lilac, 20kr olive, 20kr olive green, 24kr gray blue, 24kr pale gray blue, 30kr brown, 30kr dark brown, 50kr violet, 50kr pale violet, 1 gulden dark blue, 1 gulden deep blue, 2 gulden carmine, 2 gulden pale carmine.
- 1891, 20kr olive, 20kr olive green, 24kr gray blue, 24kr pale gray blue, 30kr brown, 30kr pale brown, 50kr violet, 50kr pale violet.
- 1896, 1 gulden lilac, 1 gulden pale lilac, 2 gulden gray green.
- 1900, 1h lilac, 1h pale lilac, 2h dark gray, 3h bistre brown, 5h blue green, 6h orange, 10h rose, 20h brown, 25h ultramarine, 25h dull blue, 30h red violet, 40h green, 50h gray blue, 60h brown, 1k carmine, 2k gray lilac, 2k lilac, 4k gray green.
- 1902, 35h green, diagonal bars of varnish.
- 1904, 1h lilac, 2h dark gray, 3h bistre brown, 5h blue green, 6h orange, 10h carmine, 20h brown, 25h ultramarine, 30h red violet, 35h green, 40h deep violet, 50h dull blue, 60h yellow brown, 72h rose, all with diagonal bars of varnish.
- 1906-07, 5h yellow green, 10h carmine, 12h violet, 20h brown, 25h ultramarine, 30h red violet.
- 1908, 1h gray black, 2h blue violet, 3h magenta, 5h yellow green, 6h buff, 10h rose, 12h scarlet, 20h chocolate, 25h deep blue, 30h olive, 35h slate, 50h dark green, 60h deep carmine, 1k purple, 2k lake & olive, 5k bistre & dark violet, 10k blue, bistre & deep brown.
- 1910, 1h gray black, 2h violet, 3h magenta, 5h yellow green, 6h buff, 10h rose, 12h scarlet, 20h chocolate, 25h deep blue, 30h olive, 35h slate, 50h dark green, 60h deep carmine, 1k purple, 2k lake & olive, 5k bistre & dark violet, 10k blue, bistre & deep brown.
- 1913, 72h dark brown.
- 1914, 5h yellow green, 10h rose.
- Newspaper stamps, 1851-56, 6kr blue, type I.
 REPRINTS, type II, 6kr blue, 6kr yellow, 6kr scarlet, 30kr rose, two shades of singles and another shade in pairs.
 1858-59, REPRINTS of 1871, type I, 1kr blue, 1kr lilac. 1884, type II, 1kr blue, 1kr lilac in pairs.
 1861, REPRINTS, 1kr gray, 1kr lilac, last in pair.
 1863, 1kr lilac, 1kr gray. REPRINT, 1kr lilac in a pair.
 1867, 1kr dull violet, 1kr lilac, type I, 1kr lilac, 1kr red lilac, type II, 1kr lilac, 1kr dull violet, type III.
 1900, 2h dark blue, 6h orange, 10h brown, 20h rose.
 1908, 2h dark blue, 6h orange, 10h carmine, 20h brown, on both chalky and ordinary papers.
- Newspaper Delivery Stamp, 1880, ½kr pale green in a pair.
- Postage Due, 1893-95, 1, 2, 3, 5, 6, 7, 10, 20, 50kr brown; 1900, perforated, 1, 2, 3, 4, 5, 6, 10, 12, 15, 20, 40, 100h brown; 1908-13, 1, 2, 4, 6, 10, 14, 20, 30, 50, 100h carmine; 1911, 5, 10k violet.

AUSTRIAN OFFICES IN THE TURKISH EMPIRE

- 1867, 2sld yellow, 3sld green, 5sld rose, 10sld light blue, 15sld bistre, 15sld orange brown, 25sld gray lilac, 50sld brown, 50sld pale brown, all with coarse beard; 2sld yellow, 3sld green, 5sld red, 10sld blue, 15sld orange brown, 25sld gray lilac, 25sld lilac, 50sld flesh (damaged), all with fine beard.
- 1883, 2sld brown, 2sld pale brown, 3sld green, 3sld pale green, 5sld rose, 5sld pale rose, 10sld blue, 10sld pale blue, 10sld dull blue, 10sld gray blue, 20sld gray, 20sld olive gray, 50sld red lilac, 50sld dull lilac.

- 1886, 10pa on 3sld green, 10pa on 3sld pale green.
 1888, 10pa on 3kr green, 10pa on 3kr pale green, 20pa on 5kr rose, 20pa on 5kr pale rose, 1pia on 10kr blue, 1pia on 10kr dull blue, 2pia on 20kr gray, 2pia on 20kr olive gray, 5pia on 50kr violet, 5pia on 50kr red violet.
 1890-92, 8pa on 2kr brown, 10pa on 3kr green, 10pa on 3kr pale green, 20pa on 5kr rose, 20pa on 5kr pale rose, 1pia on 10kr ultramarine, 1pia on 10kr dull blue, 2pia on 20kr olive, 5pia on 50kr violet.
 1892, 2pia on 20kr olive, 5pia on 50kr violet, 5pia on 50kr red lilac, 10pia on 1 gulden blue, 10pia on 1 gulden deep blue, 20pia on 2 guldens carmine.
 1896, 10pia on 1 gulden pale lilac, 20pia on 2 guldens gray green.
 1900, 10pa on 5h blue green, 20pa on 10h rose, 1pia on 25h ultramarine, 2pia on 50h gray blue, 5pia on 1k carmine rose, 10pia on 2k gray lilac, 20pia on 4k gray green.
 1903, 10pa dark green, 20pa rose, 1pia ultramarine, 2pia gray blue.
 1908, 10pa green on yellow, 20pa scarlet on rose, 30pa brown on buff, 1pia deep blue on blue, 1pia blue on azure, 60pa violet on bluish, 2pia lake on yellow, 5pia brown on gray, 10pia green on yellow, 20pia blue on gray.
 Postage Due, 1902, 10pa on 5h, 20pa on 10h, 1pi on 20h, 2pi on 40h, 5pi on 100h, green; 1908, $\frac{1}{4}$, $\frac{1}{2}$, 1, $1\frac{1}{2}$, 2, 5, 10, 20, 30pi, green, on both chalky and ordinary papers.

AUSTRIAN OFFICES IN CRETE

- 1903-04, 5c on 5h blue green, 10c on 10h rose, 25c on 25h ultramarine, 50c on 50h gray blue, 1fr on 1k carmine rose, 2fr on 2k gray lilac, 4fr on 4k gray green.
 1908, 5c green on yellow, 10c scarlet on rose, 15c brown on buff, 25c deep blue on blue, 25c blue on azure, 50c lake on yellow, 1fr brown on gray.

AUSTRIAN OFFICES IN LICHTENSTEIN

- 1912, 5h yellow green, 10h rose, 25h dark blue.

AUSTRIAN ITALY

- 1850, REPRINTS, 5c yellow, 10c black, 15c red, 30c brown, 45c blue, two shades of singles and another shade in pairs.
 1858-59, type II, 2s yellow, 3s green, 15s blue.
 REPRINTS of 1865, 2s yellow, 3s green, 3s black, 5s red, 10s brown, perforated 12.
 Of 1871, 3s green, 3s black, 5s red, 10s brown, 15s blue, perforated $10\frac{1}{2}$.

(To be continued.)

BOLIVAR.

The Stamps of 1879-1899.

By A. HATFIELD, JR., and BERTRAM W. H. POOLE.

(Continued.)

Bi-sected variety.

The 10c is known bisected diagonally and each half used as 5c. This bisection seems to have had official sanction though, strangely enough, these provisionals were not used until 1890, although no less than four other dated series had been issued between 1880 and that date. The following



80 CENTAVOS

| | | | | | | | | | |
|------|------|------|------|------|------|------|------|------|------|
| 1880 | 1880 | 1880 | 1880 | 1880 | 1880 | 1880 | 1880 | 1880 | 1880 |
| 1880 | 1880 | 1880 | 1880 | 1880 | 1880 | 1880 | 1880 | 1880 | 1880 |
| 1880 | 1880 | 1880 | 1880 | 1880 | 1880 | 1880 | 1880 | 1880 | 1880 |
| 1880 | 1880 | 1880 | 1880 | 1880 | 1880 | 1880 | 1880 | 1880 | 1880 |
| 1880 | 1880 | 1880 | 1880 | 1880 | 1880 | 1880 | 1880 | 1880 | 1880 |
| 1880 | 1880 | 1880 | 1880 | 1880 | 1880 | 1880 | 1880 | 1880 | 1880 |
| 1880 | 1880 | 1880 | 1880 | 1880 | 1880 | 1880 | 1880 | 1880 | 1880 |
| 1880 | 1880 | 1880 | 1880 | 1880 | 1880 | 1880 | 1880 | 1880 | 1880 |
| 1880 | 1880 | 1880 | 1880 | 1880 | 1880 | 1880 | 1880 | 1880 | 1880 |
| 1880 | 1880 | 1880 | 1880 | 1880 | 1880 | 1880 | 1880 | 1880 | 1880 |

ONE PESO

| | | | | | | | | | |
|------|------|------|------|------|------|------|------|------|------|
| 1880 | 1880 | 1880 | 1880 | 1880 | 1880 | 1880 | 1880 | 1880 | 1880 |
| 1880 | 1880 | 1880 | 1880 | 1880 | 1880 | 1880 | 1880 | 1880 | 1880 |
| 1880 | 1880 | 1880 | 1880 | 1880 | 1880 | 1880 | 1880 | 1880 | 1880 |
| 1880 | 1880 | 1880 | 1880 | 1880 | 1880 | 1880 | 1880 | 1880 | 1880 |
| 1880 | 1880 | 1880 | 1880 | 1880 | 1880 | 1880 | 1880 | 1880 | 1880 |
| 1880 | 1880 | 1880 | 1880 | 1880 | 1880 | 1880 | 1880 | 1880 | 1880 |
| 1880 | 1880 | 1880 | 1880 | 1880 | 1880 | 1880 | 1880 | 1880 | 1880 |
| 1880 | 1880 | 1880 | 1880 | 1880 | 1880 | 1880 | 1880 | 1880 | 1880 |
| 1880 | 1880 | 1880 | 1880 | 1880 | 1880 | 1880 | 1880 | 1880 | 1880 |
| 1880 | 1880 | 1880 | 1880 | 1880 | 1880 | 1880 | 1880 | 1880 | 1880 |

Plate V

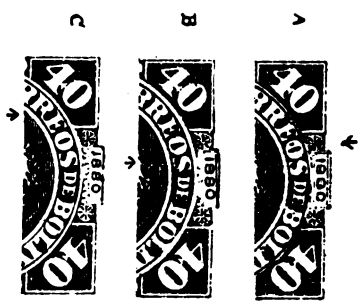
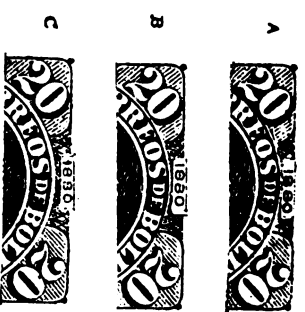
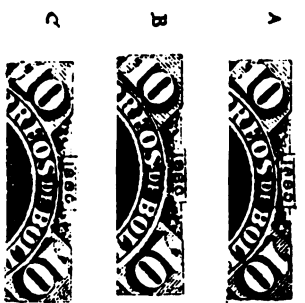
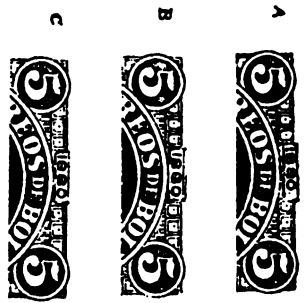

Plate VI

extract from the "Philatelic Record" for July, 1890, is interesting:—

"A correspondent informs us that when at Cartagena a month or so ago, he found the 10c mauve, dated 1880, was being employed divided diagonally as 5c stamps; and he was told by an official in the Post-office that they had no 5c of any date on hand, and that halves of the 10c would continue to be used for the lower value. He found the other values of various dates being used indiscriminately—the 80c and 1 peso of 1882 and 1883 and the 20c and 40c of various dates."

Unfortunately we are not told whether it was the variety on white wove or bluish laid paper which was bisected.

Reprints.

Reprints, or unofficial imitations, of a similar character to those found in connection with the 1879 series are also found dated 1880. Those we have met with are the 40c on white wove paper, and the 5c, 10c, 20c and 40c on bluish laid paper, all being imperforate and also the 10c on bluish laid paper, perf. 12½. These were evidently made at the same time as the similar frauds dated 1879 for they are characterised by the same small omission of the dots from the band of stars and the stones were also made up from these transfers for each value instead of strips of five as in the originals.

The three types of the 5c are as follows:—

Type A.—The small label containing the date is raised somewhat higher than in the other types. The frame line just under the date is very heavy and there are two blotches of color on the circular line below making an irregular thickening. The right end of the bottom frame line of the date label is detached from the vertical line.

Type B.—The small label containing the date is not raised so high as in type A and as a rule the top line is doubled though on some specimens it is rather faint. The bottom line has a wide break and the two short ends are very heavily drawn. On most of the stamps of this type there are short colored dashes outside the vertical frame lines, these being about ½mm distant from the frames and about 1mm. below the top of the design.

Type C.—This type also shows the small dashes outside the vertical frame lines but the lines of the date tablet are thinner and the tablet is narrower, there being less space between the top and bottom lines than on the other types. The top does not project so much as in types A and B and the lower line, which is somewhat badly drawn, shows a break under the second "8".

The three types are arranged on the sheet as follows:—

| | | | | | | | | | |
|---|---|---|---|---|---|---|---|---|---|
| C | A | C | A | A | C | A | A | C | A |
| B | A | C | A | C | C | A | B | C | A |
| C | B | C | A | A | C | A | C | C | A |
| B | C | C | A | B | C | A | B | C | A |
| A | A | C | A | B | C | A | B | C | A |

The three types of the 10c may be distinguished by the following small peculiarities:—

Type A.—The small tablet containing the date is pushed into the floral design causing the ends to curve upwards. There is a small dash of color outside the left vertical frame line about 1mm. from the top.

Type B.—There are a number of short vertical lines below the date tablet the second one from the right projecting through the lower frame line between the figures "80" of the date.

Type C.—The line of shading under the date label is darker and heavier than in type A and occupies all the space under the label. The top line of the label is separated from the vertical line at the right by a space of about ½mm.

We have no sheets or larger blocks of this reprint by means of which it is possible to reconstruct the sheet arrangement of the types.

The three types of the 20c are very easily distinguished the points of difference being:—

Type A.—The top frame line of the date tablet is in line with the top frame of the entire design.

Type B.—The upper frame line of the date tablet projects beyond the frame line of the design at its right end for the space of about $\frac{1}{2}$ mm.

Type C.—In this type the upper frame line of the date tablet also projects beyond the frame line of the design at its right end, but it is much more pronounced, being 1mm. higher.

The three types are arranged in the sheet as follows:—

| | | | | | | | | | |
|---|---|---|---|---|---|---|---|---|---|
| C | A | B | C | A | B | C | A | B | C |
| B | A | B | C | A | B | C | A | B | C |
| A | A | B | C | A | B | C | A | B | C |
| A | A | B | C | A | B | C | A | B | C |
| B | A | B | C | A | B | C | A | B | C |

The second stamp on the top row differs from other type A stamps in having an extra line over the date tablet and almost no line at all at the bottom. Other defects, however, show that it was made from the transfer designated as A.

The three types of the 40c are also quite easily identified the main points of difference being as follows:—

Type A.—There is a large colored dot on the left side of the second O of CORREOS.

Type B.—The top frame line of the small date tablet is damaged at the left and the inner line bends downwards. There is a colored smudge on the S of CORREOS.

Type C.—The tail of the second R of CORREOS has a blot of color on it making it look defective on the under side. The space between the left vertical line of the date tablet and the numeral "1" is much narrower than that between the right vertical line and the "0".

The following shows the sheet arrangement of the types:—

| | | | | | | | | | |
|---|---|---|---|---|---|---|---|---|---|
| B | A | B | C | A | B | C | A | B | C |
| A | A | B | C | A | B | C | A | B | C |
| C | A | B | C | A | B | C | A | B | C |
| B | A | B | C | A | B | C | A | B | C |
| A | A | B | C | A | B | C | A | B | C |

As in the case of the 1879 reprints the bluish laid paper is quite distinct from the laid paper of the original stamps. The colors are also different being, as a rule, in much brighter and deeper tints. The 40c, like the reprint of corresponding value dated 1879, is in a yellow brown shade never found in the genuine stamps.

Unfinished double sheets of the 1879-1880 issues.

A few sheets of stamps have come into our possession which seem to indicate that the contractor, when printing these issues, combined the two dates—probably in order to save expense. We thus have extra large sheets each containing two panes of fifty stamps, placed one above the other, the upper pane of fifty being dated "1879" and the lower one "1880". In these sheets each stamp is of the same denomination; i. e. they are all 5c, 20c or as the case may be. They were probably separated into "post-office" sheets of fifty stamps and perforated after being separated, for the ordinary single imperforate sheets exist in larger quantities than the double sheets of 100 stamps. Judging from the existence of these large sheets it seems not unreasonable to suppose that Seebeck printed supplies of both issues at the same time. This would result in considerable saving in the cost of production and as he no doubt had a contract with the Government of Bolivar extending over a number of years there was no reason why he should not make an "advance" printing of the 1880 series while he was producing those for 1879. If this theory is correct, and we consider these large double sheets are strong evidence in support thereof, then the 20c green errors of 1880 are easily accounted for. It is obvious that if this double printing

represented the usual method of procedure errors of the 1880 stamp must have been made at the same time as those for 1879, and we have already shown that the green 20c of 1879 appears to be a quite legitimate error. These double-sheets were printed in all sorts of colors and to save undue complication we have included all that we know of among the list of proofs in the check list at the end of this article.

Proofs and printers' waste of the 1879-1880 issues.

In addition to the stamps from large double sheets as described above, which, when in colors other than those chosen for the issued stamps at any rate, may well be considered as proofs, special plates of forty stamps were made showing the 5c, 10c, 20c and 40c values of both series side by side. The arrangement of these special proof sheets is always the same, there being two vertical rows of five of each denomination, the stamps of the first vertical row being dated "1879" and those of the second row "1880". The rows are separated by a space of about 10½ mm. The following diagram shows the arrangement of these sheets:—

| 1879 | 1880 | 1879 | 1880 | 1879 | 1880 | 1879 | 1880 |
|------|------|------|------|------|------|------|------|
| 5c | 5c | 10c | 10c | 20c | 20c | 40c | 40c |
| 5c | 5c | 10c | 10c | 20c | 20c | 40c | 40c |
| 5c | 5c | 10c | 10c | 20c | 20c | 40c | 40c |
| 5c | 5c | 10c | 10c | 20c | 20c | 40c | 40c |
| 5c | 5c | 10c | 10c | 20c | 20c | 40c | 40c |

These proofs are found in various colors and on papers which vary from stiff card-board to paper like that used for the stamps themselves. When these proofs were made we cannot say but they are interesting items for the specialist and our duty is to record such as we are cognisant of without necessarily expressing an opinion as to their philatelic merit. We have considered it best to give a list of the various papers and colors found in connection with each separate value in the check list which will be found at the end of this article.

The proofs of the 80c and 1 peso were arranged in sheets of fifty in a similar manner to the sheets of the stamps, but they do not show such a variation in papers and colors as the smaller denominations. There is one exception to this arrangement and that is the 1 peso of 1879 which is found in single vertical strips of five stamps. This variety is known printed in the same color and on similar paper to the issued 1 peso stamp of 1880.

In addition to such varieties as may reasonably be termed proofs there are others to which the term printers' waste or trial impressions can be more fittingly applied. These consist of impressions printed on both sides of the paper either in the adopted color of the stamps or in some fancy color; sometimes the same value is shown on both sides of the paper and sometimes two separate varieties in perhaps different colors are shown. While the philatelic interest of these items is probably not of a particularly high order we have, for the sake of completeness, given a complete list of such varieties as we have seen in the check list.

We have also seen a block of four of the 40c reprint of 1879 printed in brown on stiff card which has a crude portrait of a man at the back. In the 1880 reprints we have the 5c on thick white card, doubly printed on the face and with offset at the back; and also the same value with ordinary impression on the face and double off-set at the back. These are evidently trial impressions made when the reprints were being manufactured. Doubtless other varieties exist though we have not seen them.

V.—The Large Stamps of 1882.

In 1881 the necessity for stamps of a higher facial value than 1 peso became apparent and steps were taken to provide 5 and 10 pesos denominations. After due consideration a very handsome design was chosen and as each of the values is printed in two colors from engraved plates they make a strikingly attractive pair. The design shows a three-quarter face portrait of Bolivar on a ground of crossed horizontal and diagonal lines in the centre. This medallion is egg-shaped, the smaller end being the base, while around

it is a border of pairs of horizontal lines. This centerpiece is printed in red for the 5 pesos and blue for the 10 pesos and as the space allotted to it in the main portion of the design is smaller than its superficial area it projects on to the border to a greater or lesser extent. The border, in blue for the 5 pesos and marone for the 10 pesos, is a beautiful piece of machine engraving. We need hardly enter into a detailed description for the illustrations accompanying this article are more eloquent than any written description. The stamps were placed in issue about November, 1882, and, according to M. Moens they were engraved and printed by the American Bank Note Company, of New York. It seems much more probable, however, that they were manufactured by the older Hamilton Bank Note Company,* with which Mr. Seebeck was professionally connected. These two stamps are of especial interest as being the only ones of Bolivar printed by any process other than lithography. They were printed in sheets of sixty arranged in six horizontal rows of ten each. There are no marginal inscriptions or marks other than the small "register" marks in the side margins.

Paper.

Both denominations were printed on a hard white wove paper which occasionally shows the manufacturers' trade mark. This consists of the inscription "CRANE & CO. DALTON, MASS. 1881" in double lined letters and numerals, about $\frac{3}{8}$ in. high. This watermark is $9\frac{1}{2}$ in. long so that it extends through all the stamps of a horizontal row.

Perforation.

Both values are known perf. 12 all round and perf. 16 all round both varieties being the work of single line machines. The 5 pesos with the 16 gauge is considerably scarcer than the same value perf. 12, while in the case of the 10 pesos the perf. 12 is half as rare again as the perf. 16. This applies to unused stamps. In used condition both perforations are of about the same value on the 10 pesos while in the 5 pesos the perf. 12 is about three times as scarce as the perf. 16. Both varieties were probably in concurrent use for we notice in the earliest record we can find of their issue that the 5 pesos was recorded as perf. 12 and the 10 pesos as perf. 16. The 5 peso is known perf. 14 all round and the 10 peso rouletted. These are all exceedingly rare.

Imperforate varieties.

Although both values are found entirely imperforate we hardly think any were ever sent to Bolivar in this state. Like the imperforate values of the preceding issues they can best be described as unfinished stamps.

Essays.

While these stamps were under consideration it is probable several essays were produced but the only ones we have seen were printed by lithography in two colors and show as a central theme a profile portrait of Bolivar (exactly similar to that shown on the stamps of 1879-80) surmounted by the Colombian Arms. The border is of a somewhat elaborate character as shown in the accompanying illustrations. The 10 pesos differs from the 5 pesos in that the inscription at the base, "DIEZ 10 PESOS" is on a scroll instead of a straight tablet. In all other essential particulars the design is the same for both. In the specimens we have, the head and arms on the 5 pesos are printed in blue while the border is in carmine, and in the 10 pesos the colors are reversed the portrait and arms now being in carmine and the frame in blue. Other color combinations probably exist for M. Moens reported having received ten proofs of these essays in various colors, it being at first supposed by European collectors that this design had been definitely adopted. We have proofs of these essays in black on cardboard that seem to be of two kinds—one white and one buff or yellowish. Perhaps the

*This company has been out of existence for a number of years and is not the one now bearing the same name.

color of the latter may be due to age or some accidental treatment it may have received. We have a block of four on the white card arranged as follows:—5p. 10p.

5p. 10p.

while on the buff card we have a pair—5p. 10p. Probably these have been cut from larger sheets.

Proofs.

We have a number of proofs of both the 5 and 10 pesos printed in all sorts of color combinations. Some are printed on India paper and others are on cardboard. Many (perhaps all) of the latter are not printed direct on the cardboard but are on a thin paper which has been pasted down so carefully that the effect is the same as if the impressions had been applied direct to the thicker substance. We have a specimen of the 10 pesos on India paper with the frame printed in grey-lilac and with the centre, which is in carmine, inverted. We give a list of all the varieties we have seen in the check list at the end of this article.

(To be continued.)

CHRONICLE OF U. S. ENVELOPES.

BY J. M. BARTELS.

The following is a complete list to date of all new envelopes noted which have not been previously chronicled in the PHILATELIC GAZETTE. So far we have seen two new watermarks for the 1915 contract which consist of single line letters "U S" interlinked. Wmk. 19 has the date "1915" horizontally near the top of the letters and Wmk. 20 has the date slanting diagonally downward from left to right through the monogram.

Old Knives.

| B. No. | Denom. | Die var. | Size | Paper | Wmk. | Kn. |
|--------|--------|----------|------|-------|------|-----|
| 2456B | 2c | B | 7 | Amber | 17 | 51 |
| 2456C | 2c | B | 7 | Blue | 17 | 51 |
| 2456F | 2c | B | 8 | Amber | 17 | 59 |
| 2467C | 2c | D v.1 | 7 | Buff | 17 | 51 |
| 2467D | 2c | D v.11 | 8 | Amber | 17 | 59 |
| 2467E | 2c | D v.5 | 9 | Amber | 17 | 61 |
| 2475A | 1c | A | 2 | Amber | 18 | 79 |
| 2504A | 2c | B | 7 | White | 18 | 51 |
| 2504C | 2c | B | 7 | Blue | 18 | 51 |
| 2505 | 2c | B | 8 | White | 18 | 59 |
| 2506A | 2c | D v.13 | 1 | White | 18 | 46 |
| 2506B | 2c | D v.5 | 2 | White | 18 | 79 |
| 2509a | 2c | D v.1 | 8 | White | 18 | 59 |
| 2509k | 2c | D v.11 | 8 | White | 18 | 59 |

New Knives

| | | | | | | |
|-------|----|-------|----|-------|----|----|
| 2605A | 2c | B | 3 | Buff | 17 | 92 |
| 2606 | 2c | B | 13 | White | 17 | 89 |
| 2613a | 2c | D v.1 | 5 | White | 17 | 87 |
| 2614d | 2c | D v.4 | 5 | Amber | 17 | 87 |
| 2669A | 2c | B | 3 | Blue | 18 | 92 |
| 2670 | 2c | B | 5 | White | 18 | 87 |
| 2670D | 2c | B | 13 | White | 18 | 89 |
| 2672 | 2c | D v.5 | 3 | White | 18 | 92 |
| 2681 | 2c | D v.3 | 13 | Amber | 18 | 89 |

Wmk. 19 (1915)

| Denom. | Die var. | Size | Paper | Wmk. | Kn. | |
|---|----------|------|-------|-------|-----|----|
|  | 1c | A | 8 | White | 19 | 59 |
| | 1c | D | 13 | White | 19 | 89 |
| | 2c | A | 5 | Amber | 19 | 87 |
| | 2c | A | 13 | White | 19 | 89 |
| | 2c | A | 13 | Amber | 19 | 89 |
| | 2c | B | 5 | White | 19 | 87 |
| | 2c | B | 13 | White | 19 | 89 |
| | 2c | E | 5 | White | 19 | 87 |
| | 2c | E | 5 | Blue | 19 | 87 |
| | 2c | E | 8 | White | 19 | 59 |
| | 2c | E | 13 | White | 19 | 89 |

Wmk. 20 (1915)

| | | | | | | |
|---|----|---|----|-------|----|----|
|  | 1c | A | 8 | White | 20 | 59 |
| | 1c | D | 13 | White | 20 | 89 |
| | 2c | A | 5 | White | 20 | 87 |
| | 2c | A | 8 | White | 20 | 59 |
| | 2c | A | 9 | White | 20 | 61 |
| | 2c | A | 13 | Amber | 20 | 89 |
| | 2c | A | 13 | Blue | 20 | 89 |
| | 2c | B | 5 | White | 20 | 87 |
| | 2c | B | 9 | White | 20 | 61 |
| | 2c | B | 13 | White | 20 | 89 |
| | 2c | E | 5 | White | 20 | 87 |
| | 2c | E | 13 | White | 20 | 89 |
| | 2c | E | 13 | Blue | 20 | 89 |

BRITISH NORTH BORNEO.

The 2 Cents of 1883.

BY BERTRAM W. H. POOLE.

First issues of any country have an interest peculiarly their own and this interest is increased when the stamps afford such philatelic recreation as the possible reconstruction of the plate or plates. The issues of North Borneo, though they have been soundly anathematized in some quarters, form a particularly interesting philatelic study as I endeavored to show in the course of a short article in "Gibbons Stamp Weekly" about seven years ago. Practically all the stamps issued prior to the advent of the pictorial series of 1894 can be "plated" and though this has been successfully accomplished so far as the 1886-87 series is concerned the other issues provide virgin soil for the philatelic explorer.

Gibbons' catalogue states "The stamps of this country up to 1894 were designed by Mr. Thos. Macdonald and lithographed by Messrs. Blades, East & Blades, London". This statement is certainly incorrect insofar as it refers to the method used in manufacturing the smaller stamps. These stamps were printed by typography from electrotyped plates and though it is possible the larger stamps (25c and over) were produced by lithography it still remains to be satisfactorily proved. Indeed, a superficial study of the \$10 would seem to indicate that lithography could hardly have been the method employed, for the "DOLLAPS" error, which occurred in the early printings, is not shown in the later ones. Had this been due to a flaw on the lithographic stone it could easily have been remedied on the stone though the evidence of the necessary retouching would have been plain to philatelic eyes. The corrected stamp shows no evidence of retouching but, on the contrary, points to the fact that the plate was composed of electrotypes and the defective one was replaced with an entirely new cliché.

The British North Borneo Company was incorporated by Royal Charter on November 1st, 1881, and in May of the following year it was successfully floated as a Company by the gentlemen who had obtained the original concessions. Exactly a year later the first postage stamp for use in the territory was issued. This bore the facial value of 2 cents and was of the design shown in the accompanying illustration.



The stamps were manufactured by Messrs. Blades, East & Blades (who are perhaps better known as check printers than as stamp manufacturers), by the electrotype process. From the original engraved matrix, fifty electrotypes were made, and these, clamped together in five horizontal rows of ten, formed the printing plate. Owing to the method of production there are minute dots and defects on the stamps by which it is possible to plate this variety.

On each of the fifty stamps on the plate a small colored dot is shown on the right leg of the R of BORNEO; there is a minute colored dot between the top native character at the right and the right hand frame line; another small dot appears under the G of POSTAGE; and still another dot is shown above and to the left of the numeral "2". The figure "2" appears to vary in size—probably due to uneven contraction of the moulds used in making the reproductions from the original—that on No. 40 being noticeably larger than any of the others.

The following is a description of the peculiarities distinguishing each of the fifty stamps on the sheet:—

No. 1.—There is a large colored patch on the base of the ornament in the top left hand corner; there is a minute colored dot in the triangular patch above the "NO" of "NORTH"; and the solid color around "NORTH" encroaches upon the left lower corner of the label containing "POSTAGE".

No. 2.—The base of the ornament in the upper left hand corner is broken, there are small colored lines in both triangular spaces under the upper corner ornaments, there is a tiny colored dot in the space to the left of the ornament in the upper right hand corner, and there are two tiny colored dots on the right of the lower portion of the first native character in the left hand column.

No. 3.—The color line above the "TH" of "NORTH" is broken, and the solid color after the same word extends into the "POSTAGE" label. There is a small colored dot below the second "COMMA" in the left hand column and another before and level with the base of the figure "2". A splash of color joins the lower right leg of the ornament in the lower left corner to the frame line.

No. 4.—The lines above "POSTAGE" are badly damaged, the line to the right of the "E" of the same word is broken, and there is a small dot after that letter.

No. 5.—There is a colored line across the "O" of "NORTH", the left hand line of the square in the top right corner is broken, there is a minute colored dot between the letters "EN" of "CENTS", and there are small colored dots above and below the top native character in the right column.

No. 6.—The lines above "POSTAGE" are blurred and there is a large smudge before the same word. The "R" of "NORTH" is broken at the top, the lower "COMMA" on the left is badly shaped, and there are two dots between the letters "CE" and one under the "n" of "CENTS".

No. 7.—There is a smudge of color over the whole of the top of "POSTAGE", and the curved line under the "E" of the same word is broken. The line above the "E" of "BORNEO" is broken, and there is a small colored line outside the right hand frame almost opposite the base of the lower native character.

(To be continued.)



Published the 15th day of each month

J. KLEMMANN, Jr., Editor.

CLIFTON A. HOWES, Special Contributing Editor.

JOHN A. KLEMMANN, Managing Editor.

Staff Writers.

CHARLES LATHROP PACK

VICTOR M. BERTHOLD

J. MURRAY BARTELS

DR. CARROLL CHASE

A. E. OWEN

W. B. SPRAGUE

B. W. H. POOLE

SUBSCRIPTION \$1.00 A YEAR, SINGLE NUMBERS 10c.

Advertising Rates

| | 1 mo. | 3 mos. | 6 mos. | 9 mos. | 12 mos. |
|--------------|--------|--------|--------|---------|---------|
| 1 inch | \$1.50 | \$4.00 | \$7.75 | \$11.50 | \$15.00 |
| ¼ p. | 5.00 | 13.50 | 26.25 | 38.00 | 50.00 |
| ½ p. | 8.50 | 23.00 | 44.50 | 65.00 | 85.00 |
| 1 page | 15.00 | 40.50 | 78.75 | 114.75 | 150.00 |

NASSAU STAMP CO., Publishers, 118 NASSAU ST., NEW YORK.

VOL. V, No. 8.

NEW YORK, AUGUST, 1915.

WHOLE No. 72.

EDITORIAL.

The Philatelic Conventions.

Since our last issue there were no less than three philatelic conventions, two in the East and one in the West.

Extensive reports are printed on another page of the two conventions held in the East; the Third Annual Convention of the National Philatelic Society held July 22-24, at New York and the Southern Philatelic Association held Aug. 5-7 at Reading, Pa., but of the A. P. S. Convention held at San Francisco, we have been unable to get the report before going to press. We hope, however, to give a full detailed report of this Convention in our next issue.

The U. S. Government Collection.

We again take up the catalogue of the stamps in the U. S. Government Collection of postage stamps and in this issue will be found the beginning of the list of the foreign issues.

Much interest has been shown in the Government Collection and from reports received, the stamp section is becoming one of the most popular in the Museum, and the visitors are not all stamp collectors either.

The results of two year's careful work, done by the most scientific philatelist the Government could have obtained, are beginning to show and the exhibit is such that it is a revelation not only to those who know nothing regarding stamps but more so to those who do.

September.

September is always looked upon as the month for the resumption of philatelic activities which have been temporarily discontinued but in recent years this marked division of time has not been so arbitrarily noted and collectors generally are devoting as much time to their collections during the hot summer months as at any time of the year.

The Cycle.

It is not often that the sad duty devolves upon us to report the deaths of three prominent philatelists in any one of our issues but such is our lot this month.

We extend to their respective families our deepest sympathy in their loss.

Egbert Bagg.

Mr. Egbert Bagg passed over to the great majority on the morning of July 11, 1915, at his home in Utica, New York. He was born in that city on Aug. 10, 1850 and spent most of his life there taking an active part in the public and business life of that city. He leaves a widow and four children to whom we extend our deepest sympathy in their bereavement.

Harry Wesley Legg.

Every collector or dealer in stamps knew Harry Legg. If they did not know him personally they knew who he was. Those who knew him personally knew him as a good, cheerful and genial friend whose greatest delight was to make his friends happy. In his business relations there was none better posted or fairer in his dealings and his death marks the loss of one of the strong men of the philatelic world. Mr. Legg died July 21, 1915 at the very early age of 32, and was buried in Arlington Cemetery, on July 24th.

He is survived by a widow to whom all who knew Mr. Legg extend their deepest sympathy in her great sorrow.

Melville Stewart.

To readers of the PHILATELIC GAZETTE, Mr. Melville Stewart is not entirely unknown and they will be exceedingly sorry to learn of his sudden death from heart failure on the 5th of August. Mr. Stewart was without doubt, the leading baritone in light opera and in his professional experience created and sang over one hundred leading baritone roles, touring the country last season with Mme. Trentini in "Mme. Butterfly".

He leaves a widow, Mme. Genevieve Finlay-Stewart, the well-known mezzo-soprano, and one son, to whom we extend our deepest sympathy in their great loss.

THE CONFEDERATE STATES OF AMERICA.

A HISTORY OF THE GENERAL ISSUES.

BY BERTRAM W. H. POOLE.

(Continued.)

Judge John H. Reagan was appointed Postmaster-General of the Confederacy and, as will be seen from the foregoing, the Act of March 15th, 1861, Congress gave him a very free hand in organizing his Department. In order to give postmasters ample time for getting their affairs in order as related to their official dealings with the United States Government, June 1st., 1861, was fixed as the date on which postal affairs should be officially taken over by the Confederate States and a proclamation to this effect was issued on May 13th, 1861, viz:—

BY THE POSTMASTER-GENERAL OF THE CONFEDERATE STATES OF AMERICA.

A PROCLAMATION.

Whereas, By the provisions of an Act approved March 15, 1861, and amended by the first section of an Act approved May 9, 1861, the Postmaster-General of the Confederate States is authorized, on and after a day to be named by him for that purpose, to take the entire charge and direction of the postal service in the Confederate States, and all conveyance of mails within their limits from and after such day, except by authority of the Postmaster-General thereof, is thereby prohibited.

Now, therefore, I, John H. Reagan, Postmaster-General of the Confederate States of America, do issue this my Proclamation, notifying all postmasters, contractors, and special and route agents, in the service of the Post-Office Department, and engaged in the transmission and delivery of the mails, or otherwise in any manner connected with the service within the limits of the Confederate States of America, that on and after the 1st. day of June next, I shall assume the entire control and direction of the postal service therein: And I hereby direct all postmasters, route agents, and special agents within these States, and now acting under the authority and direction of the Postmaster-General of the United States, to continue in the discharge of their respective duties under the authority vested in me by the Congress of the Confederate States, in strict conformity with such existing laws and regulations as are not inconsistent with the laws and Constitution of the Confederate States of America, and such further instructions as may hereafter be issued by my direction: And the said postmasters, route agents, and special agents are also required to forward to this Department, without delay, their names, with the names of the offices of which they are postmasters (giving the State and county), to be directed to the "Chief of the Appointment Bureau, Post-Office Department, Montgomery, Alabama", in order that new commissions may be issued under the authority of this government: And all postmasters are hereby required to render to the Post-Office Department at Washington, D. C., their final accounts and their vouchers for postal receipts and expenditures, up to the 31st. day of this month, taking care to forward with said accounts all postage stamps and stamped envelopes remaining on hand, belonging to the Post-Office Department of the United States, in order that they may receive the proper credits therefor, in the adjustment of their accounts, and they are further required to retain in their possession, to meet the orders of the Postmaster-General of the United States, for the payment of mail service within the Confederate States, all revenue which shall have accrued from the postal service prior to the said 1st. day of June next.

All contractors, mail messengers and special contractors for conveying the mails within the Confederate States, under existing contracts with the Government of the United States, are hereby authorized to continue to perform such service under my direction, from and after the day last above-named, subject to such modifications and changes as may be found necessary, under the powers vested in the Postmaster-General by the terms of the said

contracts and the provisions of the second section of an Act approved May 9th, 1861, conformable thereto, and the said contractors, special contractors, and mail messengers are required to forward, without delay, the number of their route or routes, the nature of the service thereon, the schedules of arrivals and departures, the names of the offices supplied, and the amount of annual compensation for present service, together with their address, directed to the "Chief of the Contract Bureau, Post-Office Department, Montgomery, Alabama."

Until a postal treaty shall be made with the Government of the United States for the exchange of mails between that government and the government of this Confederacy, postmasters will not be authorized to collect United States postage on mail matter sent to or received from those States, and until supplies of postage stamps and stamped envelopes are procured for the prepayment of postage within the Confederate States, all postages must be paid in money, under the provisions of the first section of an Act approved March 1, 1861.

Given under my hand and seal of the Post-Office Department of the Confederate States of America, at Montgomery, Alabama, the 13th day of May, in the year 1861.

JOHN H. REAGAN,
Postmaster-General.

Although the Postmasters' Proclamation was not published until May he made preparation for obtaining a supply of postage stamps soon after the Act of March 15th was passed. On March 27th, 1861, an advertisement inviting tenders for the supply of stamps and stamped envelopes was inserted in a number of newspapers. The text of this advertisement was as follows:—

PROPOSALS FOR POSTAGE STAMPS.

Confederate States of America,

Post-Office Department,

Montgomery, March 27, 1861.

Sealed proposals will be received at this department until 3 o'clock p. m., on the 1st day of May next, for furnishing for the use of the Post-office in the Confederate States, postage stamps, of the denominations of 2, 5, 10 and 20 cents.

The postage stamps must be perforated around their edges, and well gummed, put up in packages of one hundred sheets each, and delivered to the department free of charge, and in such quantities as may be required to fill the orders of Postmasters.

Proposals are also invited for furnishing strawboard boxes for packing parcels of postage stamps, of from 100 to 500 sheets each, and for tin boxes of equal capacity, to be delivered at the department. The dies for embossing the postage stamps are to be executed in the best style, and they are to be provided, renewed, and kept in order at the expense of the contractor.

Bond and security will be required for the faithful performance of the contract, and payment will be made quarterly.

Each bidder must submit samples of the postage stamps proposed to be furnished, and also furnish evidence of his ability to comply with his bid. The price, quality of samples, and sufficiency of the bidder, will be considered together in awarding the contract, and the Postmaster-General reserves to himself the right to annul it whenever he shall discover that the same, or any part of it, is offered for sale in the market for the purpose of speculation, and he will in no case sanction a transfer of the contract to any party who shall be, in his opinion, less able and qualified than the original bidder or contractor.

The right is also reserved to annul the contract for a failure to perform faithfully any of its stipulations.

Bidders will state the earliest period at which they will be able to furnish supplies of the articles bid for, in the event of the contract being awarded to them, as it will have an important bearing upon the awards. But bids will not be entertained which fix a period beyond the first of July next for the delivery of supplies.

The bids should be marked "Proposals for Postage Stamps" and addressed, "Chief of Finance Bureau", Post-office Department, Montgomery, Alabama.

JOHN H. REAGAN, Postmaster-General.

At the same time tenders were invited for a supply of stamped envelopes but as these were never manufactured it is hardly necessary to reproduce the official advertisement. Evidently the Postmaster-General was of an optimistic turn of mind for not only did he ask for supplies of 2c, 5c, 10c and 20c stamps in such quantities "as may be required" but he also stipulated they should be perforated and refused to entertain a bid which could not promise a first delivery by July 1st, 1861. As events transpired he had to wait until October before stamps of any denomination were procurable, had to forego the convenience of perforation, and accept the stamps in such limited quantities as the printers could furnish. In an Official Report, dated November 27th, 1861, the Postmaster-General gives an illuminating account of the trials and vexations he encountered in his efforts to obtain postage stamps for the Confederacy and as this is of particular interest I reproduce it in full:—

The difficulties which have been encountered by the Department in its endeavors to procure postage stamps and stamped envelopes, producing great delays in procuring them in such quantities as to meet the demands of the public, have caused much impatience to be manifested on that account, which induces me to state at some length the various efforts made by the Department to procure them, as well for the information of Congress as for the vindication of the Department against charges of neglect of duty in that respect.

The manifest advantage of having stamps and stamped envelopes for the payment of postage has been from the first fully realised by the Department, and immediately after my appointment, and before the Department was organised, correspondence was commenced with such parties as were known to be able to manufacture them, for the purpose of procuring them at the earliest day possible. Propositions were submitted early in March last from parties not residing in the Confederate States to supply them, and the Department was led to believe they ought to be obtained by the time it could be organised, and prepared to take control of the service. But the political changes then going on so rapidly, and the increasing probabilities of hostilities between the new and the old Governments, soon reduced the fulfilment of the first proposition to furnish stamps and stamped envelopes impossible.

On the 16th March a proposition was submitted by a gentleman having the means and capacity for manufacturing them, to establish a house in the city of Montgomery for that purpose, and for the purpose of doing any other engraving, lithographing, and printing which might be required by the Government. Assurances were given him that he should have the contract for furnishing stamps and stamped envelopes, and, at his request, and to facilitate the early manufacture of them, he was furnished by the Department with designs for the various denominations of stamps, in order that he might complete the necessary engravings by the time his presses and other material could be prepared. He left that city, as he said, for the purpose of carrying into effect that enterprise, and nothing was heard from his afterwards.

On the 27th of March the Department advertised for proposals for furnishing stamps and stamped envelopes in newspapers in the following cities, to wit:—Montgomery, New Orleans, Charleston, Baltimore, Philadelphia, New York, Savannah, Columbus, Richmond, Memphis, and Louisville. No proposals in response to this advertisement were received from any establishment in the then Confederate States. The only proposals made in answer to this advertisement were one from Richmond and one from Baltimore, proposing to furnish lithographed stamps. The proposition from Baltimore was regarded as most favorable, both on account of the style of the work proposed to be done and the terms on which the supplies were proposed to be furnished. But the collision between the citizens of that city and the Federal troops on the 20th of April, and consequent suspension of communication with that city, prevented further negotiations on the subject.

A skilful engraver, not a citizen of the Confederate States, visited Montgomery early in May for the purpose of entering into a contract to furnish stamps and stamped envelopes, to be executed in the highest style of art. When there it became manifest that the condition of affairs between the United States and our Government would interrupt the de-

livery of these articles from the place at which he proposed to manufacture them. He then entered into an agreement to make the stamps in the Confederate States, subject to the contingency of his being prevented from introducing the necessary machinery by hostilities between the two Governments. In June the Department received notice from him that it would be out of his power to introduce the machinery and fulfil his agreement.

In July a confidential agent was employed by the Department to procure the making of the required steel die and plates for postage stamps, and to furnish them to the Department as soon as they could be prepared; and also, if found practicable, to have the stamps made and furnished ready for use.

After receiving some encouragement, and after the work of making steel dies had commenced, circumstances rendered the discontinuance of the work by the manufacturer necessary. And our agent then made an effort, at another point, to procure lithographed stamps of a superior style, and after some delay it became necessary to abandon that effort to supply the Department. This brought us to September. And in the meantime an extensive correspondence was kept up by the Department, and has been steadily persevered in up to this time, with persons in various cities in the Confederate States, and indeed with every person who was represented to the Department as an engraver, who might execute the work desired. Urged by the wants of the public, the Department was induced, as a temporary expedient, to make arrangements with a lithographic establishment in this city for the manufacture of lithographed stamps. Unexpected delay, however, occurred in the preparation of them; and after the completion of the plates, the supplies furnished to the Department were so insufficient to meet the demand for them, and the prices charged so exorbitant, as compared with the cost of the superior steel plate impressions in use in the United States and other Governments, that a special agent was despatched on the 27th of October to Charleston, S. C., and Savannah, Ga., for the purpose of ascertaining the practicability of having stamps printed there on more favorable terms, and in quantities equal to the public demand. This agent returned to the Department November 4th, and reported that the engravers of those cities would submit estimates to the Department as soon as they could ascertain the cost of machinery and paper. I have just received a letter from Charleston submitting a proposal for furnishing stamps, but stating that it would require at least ninety days for the preparation of the necessary machinery and plates.

This engraver proposes to furnish the stamps gummed, but not perforated at a cost of one dollar per thousand, the paper to be furnished by the Department, whereas the United States Government paid but eighteen cents per thousand stamps, gummed, perforated, and put up in tin and paper boxes and envelopes, without extra charge for paper and boxes and envelopes.

The engraver in Savannah, under date of 21st of November, states that it will require sixty days to prepare the plates for printing each denomination, and the delivery of 400,000 stamps, and that with his present force he can only furnish 80,000 stamps daily. The estimated number required for daily use is about 260,000. In the meantime, on the first day of October, a confidential agent was provided with ample means, and despatched to Europe to procure the manufacture of steel dies and plates for printing stamps of the several denominations provided by law, and for procuring for use, as soon as practicable, fifteen millions of stamps, and to forward the dies, plates, and stamps to this city. The small supplies now being received from the contractors in this city only serve to increase the public discontent, as they are insufficient to meet the demands of even the principal cities.

It is a fact well established by the experience of other Governments and of bankers generally, that impressions taken from skillfully-prepared steel dies and plates are the only safeguard against counterfeiting, and the Department has been very reluctant to adopt any other character of postage stamps.

The Department has received several propositions from persons professing a knowledge of the art of engraving and preparing stamps,

but correspondence and investigation have shown that they had neither the required skill and the knowledge for this purpose, nor the means of furnishing the stamps, and were ignorant of the requirements for the preparation of them. When prepared and supplied as they should be, to all offices, they will represent the entire revenues of the Department.

There is a popular delusion resting on the minds of many that almost any kind of engraving will answer for postage stamps, and in support of this opinion, reference is frequently made to the fact that postmasters of different cities and towns have procured stamps for their offices. These are made upon wood, or stone, or lead, or are electrotypes. Stamps prepared by either of these modes can be counterfeited with great facility by a mere tyro in the art of engraving, and the Department could not risk its revenues on such slender security without disregarding the public interest.

(To be continued.)

THE POSTAL ISSUES OF AUSTRIA.

BY J. BRACE CHITTENDEN, Ph. D.

(Continued.)

NINTH ISSUE.



III. 90.

From March 1891 to Sept. 30th, 1900.

Bust of the Emperor to left in rectangle, the four corners of which are cut diagonally by small hexagons containing the figures of value in black on a white ground. The frame of the rectangle contains on the sides, the words "Kais. Konigl. Oesterr. Post", and above and below the word Kreuzer. On each side of the figures in the corners there is a colored dot. Paper as in the preceding issue of two sorts. No watermark, Perforation $9\frac{1}{4}$ to 14. Illustration 90.

TABLE 28.
1891-1900.

| | A. p. 10 Rg. 10½, 11 | B. p. 9¼ | C. p. 11 | D. p. 12½ 2d paper | E. p. 13½ 2d paper | | | | |
|-------------------------|-------------------------|----------|----------|-----------------------|-----------------------|---------|-----|-----|-----|
| 53 20K. yellow olive | .12 | .01 | — | 3.00 | .62 .25 .02 | — | .08 | | |
| a 20K. olive green | | | | | | | | | |
| b 20K. gray green | | | | | | | | | |
| 54 24K. light blue | .15 | .01 | — | 5.00 | .50 .62 | .10 | — | .20 | |
| a 24K. dark blue | | | | | | | | | |
| 55 30K. light yel. brn. | .18 | .01 | — | 2.50 | 3.75 | .25 .65 | .05 | — | .08 |
| a 30K. dark yel. brn. | | | | | | | | | |
| 56 50K. bluish violet | .31 | .05 | — | 6.25 | .75 .75 | .18 | — | | |
| b 50K. reddish violet | | | | | | | | | |

See perforation table.

TENTH ISSUE.

From Feb. 1896 to Sept. 30th, 1900.

The 1 and 2 Guldens with the colors changed. Illustration 89.

TABLE 29.

| | A. p. 10½, | | B. p. 12½ | |
|-------------------------------|------------|-----|-----------|-----|
| | 11½ | | | |
| 57 1G. light gray lilac | .63 | .05 | .75 | .62 |
| a 1G. dark gray lilac | | | | |
| 58 2G. light sea green | 1.12 | .50 | | |
| a 2G. dark sea green | | | | |

NOTE 1. Issues 9 and 10 really form part of the eighth issue. The higher values 20, 24, 30 and 50K were changed by a decree of March 11, 1891, because, especially in the evening, they were hard to distinguish from certain of the lower values. In 1898 the complete perforating machines were in operation so they are the last to show many variations of line perforations.

TABLE 30.

Complete Perforation Table.

1891 and 1896 (No. 53-58)

| Perfs. | Kreuzers | | | | Gulden | | Paper |
|----------------|----------|----|----|----|--------|---|------------|
| | 20 | 24 | 30 | 50 | 1 | 2 | |
| 10 (rg.) | 20 | 24 | 30 | 50 | — | — | 1st and 2d |
| 9¼ | — | — | 30 | — | — | — | 1st |
| 10½ | 20 | 24 | 30 | 50 | 1 | 2 | 2nd |
| 11 | 20 | 24 | 30 | 50 | — | — | 1st |
| 11½ | 20 | 24 | 30 | 50 | 1 | 2 | 2nd |
| 12½ | 20 | 24 | 30 | 50 | 1 | — | 2nd |
| 13½ | 20 | 24 | 30 | — | — | — | 1st and 2d |

Prices for used copies.

| Comp. Perfs. | Kreuzer | | | | Gulden | |
|-----------------|---------|------|------|------|--------|------|
| | 20 | 24 | 30 | 50 | 1 | 2 |
| 9¼ : 11½ | — | 6.25 | — | — | — | — |
| 9½ : 12½ | — | 6.25 | — | — | — | — |
| 10½ : 9¼ | — | — | 7.50 | — | — | — |
| 10½ : 11½ | 3.00 | — | 1.25 | 2.50 | 1.50 | — |
| 10½ : 12½ | 2.00 | .75 | .75 | 3.00 | 2.00 | 5.00 |
| 10½ : 13½ | — | 2.00 | 3.75 | — | — | — |
| 10½ : 14 | — | 2.50 | — | — | — | — |
| 11½ : 10½ | 2.00 | 2.50 | 2.00 | — | 1.50 | — |
| 12½ : 10½ | 1.25 | .75 | 1.00 | 2.50 | 2.50 | — |
| 13½ : 10½ | — | 2.00 | 1.25 | — | — | — |
| 14 : 11½ | 2.50 | — | — | — | — | — |

See Note to table, issue of 1890.

NOTE 2. The 50K. No. 55 exists in pairs, middle imperf. (\$25.00) and Kropf lists the 20, 24 and 50K with mixed perforations although Kohl mentions only No. 56. perforation 12½ on three sides and 10½ on the left, quoting Philatelist (1908) P. 141.

NOTE 3. Yellow bars which were regularly introduced in the paper in 1901 composed of bands of varnish placed diagonally across the stamps were tried on certain sheets of the last three issues. As the object was to prevent cleaning, they were of course cancelled by way of experiment and as usual the local dealers got hold of them. They are too scarce to find postally used, but it has occurred at rare intervals. Considered as essays Nos. 40-46 and 53-56 \$25.00 per set.

900 of the 1, 2, 3, 5, 15K.

800 of the 10, 12, 24, 30, 50K.

700 of the 20K.

Perforation 13, 12½, (1, 2, 3, 5, 10, 12, 15 and 50K.)

Perforation 12½ (20, 24, 30K.)

NOTE 4. Herr Kropf lists as existing perforations the following.

TABLE 31.

PERFORATIONS (1891-1900) (Kropf).

| Perfs. | 20 | 24 | 30 | 50 | Perfs | 20 | 24 | 30 | 50 |
|---------|----|----|----|----|---------|----|----|----|----|
| 9 | — | — | 30 | — | 11:11½ | — | — | 30 | — |
| 9½ | 20 | 24 | 30 | — | 11½ | 20 | 24 | 30 | 50 |
| 9½:9 | 20 | — | — | — | 11½:10½ | 20 | — | 30 | — |
| 10 | 20 | 24 | 30 | 50 | 12½ | 20 | 24 | 30 | 50 |
| 10½ | 20 | 24 | 30 | 50 | 12½:10½ | 20 | 24 | 30 | — |
| 10½:11½ | — | — | 30 | — | 13 | 20 | 24 | 30 | 50 |
| 10½:12½ | 20 | 24 | 30 | 50 | 13:10½ | — | 24 | 30 | — |
| 10½:13½ | 20 | 24 | 30 | — | 13½ | 20 | 24 | 30 | — |
| 11 | 20 | 24 | 30 | 50 | 13½:10½ | — | — | 30 | — |

(To be continued).

NEW ISSUE NOTES.

We are indebted to Mr. J. B. Leavy for the copy of the circular sent out by the Director of the Universal Postal Union under date of June 22d, announcing the June distribution, which we print herewith.

1st, Denmark: Post card of 10+10 ore and official post card of 3 ore; post card of 5 bit for use in the Danish West Indies and letter sheet of 4 ore for use in Iceland.

2nd, French Colonies:

Somali Coast: Postage stamp of 10+5 centimes of the red cross;

Guadeloupe: Postage stamp of 10+5 centimes of the red cross;

Martinique: Postage stamp of 10+5 centimes of the red cross.

3rd, Great Britain:

Nigeria: Postage stamps of 3 pence and of 10 shillings;

Trinidad & Tobago: Postage wrappers of ½ penny and of 1 penny.

4th, Luxembourg (Grand Duchy): Postage stamps of 30, 35, 37½, 40, 50, 62½ centimes, 1 franc, 2½ and 5 francs (These stamps have been in circulation since the 1st December 1914).

5th, Persia. Issue commemorative of the coronation of H. I. M. the Shah of Persia:

(a) Postage stamps of 1, 2, 3, 5, 6, 9, 10, 12 and 24 chahis (crown issue of Persia);

(b) Postage stamps of 1 kran, 2, 3 and 5 krans (Darius issue);

(c) Postage stamps of 1 toman, 2, 3 and 5 tomans (Persepolis issue);

(d) Postal packet stamps of 1, 2, 3, 5, 6, 9, 10 and 12 chahis (crown issue of Persia);

(e) Postal packet stamps of 1 kran, 2, 3 and 5 krans (Darius issue);

(f) Postal packet stamps of 1 toman, 2, 3 and 5 tomans (Persepolis issue);

(g) Official stamps of 1, 2, 3, 5, 6, 9, 10, 12 and 24 chahis (crown issue of Persia);

(h) Official stamps of 1 kran, 2, 3 and 5 krans (Darius issue);

(i) Official stamps of 1 toman, 2, 3 and 5 tomans (Persepolis issue);

(These stamps have been in circulation since the 24th of April last, concurrent with those of the issue of the Sultan Ahmed Shah; their duration of validity is unlimited. The values mentioned under the letters a—f, sub-index, are utilized in the interior and international service, and the official stamps, in the Persian interior service only).

6th, Portuguese Colonies:

(a) Portuguese India: Postage stamp of 8 tangas with the portrait of Dom Louis, bearing in red surcharge the word "Republica" and in black surcharge the mention "5 tangas"; 2 tangas with the portrait of Dom Carlos (2nd issue), bearing in red surcharge the word "Republica" and in black surcharge the mention "Provisorio"; 2½ tangas with the portrait of Dom

Carlos (2nd issue), bearing in red surcharge the word "Republica" and in black surcharge the mention "2 tangas". The indication "2½ tangas" is barred out by a blot;

(b) St. Thomas & Prince Islands: Postage stamps of 10 and 300 reis with the portrait of Dom Louis, bearing in red surcharge the word "Republica" and in black surcharge the mention "115 reis";

5 reis with the portrait of Dom Carlos, bearing in red surcharge the word "Republica" and the mention "130 reis";

200 reis with the portrait of Dom Louis, bearing in red surcharge the word "Republica" and in black surcharge the mention "130 reis";

25, 150 and 200 reis with the portrait of Dom Carlos (1st issue), bearing in red surcharge the word "Republica" and in black surcharge the mention "115 reis";

75, 100 and 300 reis with the portrait of Dom Carlos (1st issue), bearing in red surcharge the word "Republica" and in black surcharge the mention "130 reis";

50 reis with the portrait of Dom Carlos (2nd issue), bearing in red surcharge the word "Republica" and in black surcharge the mention "Provisorio";

65 reis with the portrait of Dom Carlos (2nd issue), bearing in red surcharge the word "Republica" and in black surcharge the mention "50 reis". The numerals "65" are barred out by a blot;

(c) Zambezia: Postage stamps of 5, 25 and 80 reis with the portrait of Dom Carlos (1st issue), bearing in red surcharge the word "Republica" and in black surcharge the mention "115 reis";

75 and 150 reis with the portrait of Dom Carlos (1st issue), bearing in red surcharge the word "Republica" and in black surcharge the mention "130 reis";

2½ reis of the 1st issue of Dom Carlos bearing in red surcharge the word "Republica" and in black surcharge the mention "130 reis";

50 reis with the portrait of Dom Carlos (2nd issue), bearing in red surcharge the word "Republica" and in black surcharge the mention "Provisorio";

65 reis with the portrait of Dom Carlos (2nd issue), bearing in red surcharge the word "Republica" and in black surcharge the mention "50 reis". The numerals "65" are barred out by a blot.

NOTES

NIGERIA are on paper colored through.

LUXEMBOURG are of same design as four values already known; the colors are as follows: 30c yellow brown, 35c indigo, 37½c brown, 40c red orange, 50c slate, 62½c deep blue green, 1fr red brown, 2½fr rose red, 5fr slate violet.

PERSIA, the stamps of crown issue are large with a central design of the Persian Imperial Crown enclosed on the sides and bottom by two laurel branches tied with a bow; above, a Persian inscription on a ribbon band, and below, also on a ribbon, POSTES PERSANES, all on a background of rays emanating from a white circle bearing the crown. This entire design is enclosed in a fancy border with white circles in the four corners and a white octagon in upper and lower centre; the upper circles bear the Persian characters of value, the upper octagon the Persian date characters, the lower left the numeral of value, the lower right circle the letters Ch, and the lower octagon the date 1914, all in color. With the exception of three values the stamps are bi-colored, the color of the border being given first;

1ch dull rose & indigo, 2ch blue & carmine, 3ch green, 5ch red, 6ch olive, 7ch carmine, 9ch yellow brown & violet, 10ch blue green & yellow brown, 12ch ultramarine, 24ch yellow brown & brown.

The stamps of the Darius issue are large tri-colored stamps, bearing a central allegorical design representing King Darius seated on the throne, and copied from a bas-relief on the door-frame of the Hall of a Hundred Columns at Persepolis, enclosed in an irregular frame of fancy design having octagons in the four corners, the upper bearing the Persian characters of value, the lower left the numeral of value, and the lower right the letters Kr; in

the top and bottom centre of the frame are labels with curved ends, the top bearing a Persian inscription and the bottom Postes Persanes; on the left of the central design are the Persian date characters, on the right 1914, both in the color of the frame. The entire central design and frame are enclosed in a border of silver. The color of the allegorical design is given first, then the frame, then the border.

1kr gray, yellow brown & silver. 3kr drab, violet & silver.
2kr carmine, blue & silver. 5kr greenish gray, gray brown & silver.

The stamps of the Persepolis issue are large tri-colored stamps with a central design of a section of the ruins of Persepolis enclosed in a fancy border of gold and color; an irregular label in the top border contains a Persian inscription, one in the left border 1914, one in the right border the Persian date characters; in the lower corners irregular circles contain the Persian characters of value, an irregular shaped label in the bottom border, encroaching upon the central design, bears the numeral of value and the word toman or tomans, and at the bottom of the central design, in the color of the border, are the words Postes Persanes. The color of the central design is given first.

1t black, purple & gold. 3t red brown, maroon & gold.
2t gray brown, green & gold. 5t indigo, blue & gold.

The parcel post stamps are the regular stamps of the three series overprinted in black with a Persian inscription and the words COLIS POSTAUX. The official stamps are the regular stamps of the three series overprinted in black with a Persian inscription and the word SERVICE.

We reprint from the Colonial Journal the following information and list of new British Colonial stamps, issued during the last quarter.

Ceylon.—The 2 rupee stamps have now been supplied printed from a new key plate No. 3 on C. A. yellow paper. The 10 rupee stamps have also been printed from plate No. 3.

East Africa Protectorate.—The 25c stamps are now printed on C. A. yellow paper.

Fiji.—The 1s. stamps have been supplied printed on C. A. green paper.

Jamaica.—The 3d. and 1s. postage and revenue stamps are now printed on C. A. yellow and green paper respectively. The 3d. and 6d. stamps have also been overprinted "Judicial." This is the first occasion on which these duties have been so supplied. The 5s. postage and revenue stamp overprinted "Judicial" is now printed on C. A. yellow paper.

Nyasaland Protectorate.—A supply of 2d. stamps is in course of preparation.

Straits Settlements.—The 5, 25 and 30 cent stamps have been supplied printed from the new plate No. 3.

Mr. Lawrence B. Mason informs us that the postal authorities at Lisbon will soon issue the last remaining lot of the 1902 Provisionals with the Republica overprint.

There are twenty of them and all of the 400r denomination, making a total face value of \$8.00. We believe that this is really the end of these Provisional Lisbon issues as the stamps noted below were those which were stricken from the official list which we printed in our January issue.

Surcharged on Don Carlos Issue.

Angola, 400 on 2½r, 400 on 50r, 400 on 200r.
Cape Verde, 400 on 2½r, 400 on 300r.
Congo, 400 on 80r, 400 on 150r, 400 on 200r.
Guinea, 400 on 75r, 400 on 80r, 400 on 100r.
Mozambique, 400 on 50r, 400 on 80r, 400 on 300r.
St. Thomas, 400 on 2½r, 400 on 50r, 400 on 80r.
Zambesia, 400 on 50r, 400 on 100r, 400 on 200r.

United States.

During the past month three new stamps have made their appearance. The 10c Panama-Pacific has appeared with the 10 perforation.

An entirely new denomination, 11 cents, has been issued. It is the same type as the Franklin set of 1912-14. The color is very dark green and the perforation, 10. The plate numbers are 7498, 7499, 7504 and 7505.

The 2c has come with the new 11 perforation which the Department has now adopted as the permanent and most satisfactory perforation.

SOCIETY NOTES.

American Philatelic Society.

The Annual Convention of the American Philatelic Society was held at San Francisco, August 10, 11, 12.

At the present writing we have no details except the announcement of the election of the following officers:

President, C. A. Howes of Massachusetts.
 Vice President, Carroll Chase of New York.
 Vice President, W. B. Sprague of New York.
 Vice President, H. H. Wilson of New York.
 Secretary, W. E. Ault of Indiana.
 Inter. Sec'y, L. Harald Kjellstedt of Pennsylvania.
 Treasurer, C. F. Heyerman of Michigan.
 Director at Large, H. B. Phillips of California.
 Director at Large, W. H. Barnum of Ohio.

International Society of Postage Stamp Dealers, Paris.

In our previous communication there occurred an error respecting the designation of the Members who constituted the above-mentioned Society and whose names are as follows:

President, M. Lemaire.
 Vice-Presidents, Messrs. Champion and Vervelle.
 Secretary, M. R. Poulain.
 Asst. Secretary, M. Marquet.
 Treasurer, M. Lebrou.
 Manager of the Bulletin, M. Lemierre.
 Superintendent of the Circulation of Stamps, M. Roland.
 Assessors: Messrs. E. Chevilliard, M. Lescut, E. Matthey and J. Thumin.

Members: Messrs. Bernard, Delacourcelle, Farges, Ferroud, G. Gilbert, A. O. Marimian, A. Moreaux, Nicolaides, Niel, V. Perron, O. Roumet and Yvert and Tellier.

The Society is confident that all American philatelic Fellows will be kind enough to join and give it every assistance in order to carry out successfully the task it assumes; their precious aid will in anticipation be much appreciated.

TH. LEMAIRE, President.

National Philatelic Society.

Report of the Third Annual Convention.

The Third Annual Convention of the National Philatelic Society, was held on the 22d, 23d and 24th of July, 1915, at New York, the home of the New York Philatelic Exchange Society, Branch #3 of the N. P. S. at the Aschenbroedel Hall, #144 East 86th Street.

The first session was called to order at 8:30 P. M. with E. L. Weiss, President, in the chair. W. E. Goodwin, the secretary, not being present, E. L. Clark of Lynn, Mass., was selected secretary pro tem. Seventy-three members attended.

President Weiss made a short speech of welcome to visitors and members, extending to them the privileges of the Club.

The minutes of the previous meeting were read, approved and accepted. The party then adjourned to the banquet hall.

President Weiss was selected toastmaster, and short speeches were made by several well-known philatelists: John W. Scott, who is undoubtedly the oldest dealer in the United States, told how he started in business, and how little he ever expected to sell a single stamp for over One Thousand dollars. He was followed by A. M. Wright of Roslindale, Mass., who told a good story, and ended by inviting the N. P. S. to Boston, for the next convention. Then followed speeches by P. M. Wolsieffer, of Philadelphia, Pa.; J. M. Bartels, of New York; A. C. Bartley, Pres. of the Montclair Branch of the N. P. S., Montclair, N. J.; M. Ohlman, Pres. of the A. S. D. A., of New York; M. B. Clark, of Lynn, Mass., who was the first president of the N. P. S., or the Lynn Philatelic Society, as it was then called. G. Denzau of Brooklyn, N. Y., Secretary of the New York Stamp Society, and M. Herbert, Pres. of the N. Y. P. E. S., of New York, then extended their own personal welcome to the visitors, followed by E. H. Gammans, Jr., of the Brooklyn Stamp Society, and E. L. Clark, Vice-Pres. of the N. P. S.

At 9:30 P. M. a flash-light photograph was taken of the entire gathering, which was finished and shown before adjournment.

At the auction which followed, several good lots of stamps were offered, the proceeds of which are to be applied to the recruiting work of this society. The lots were donated by members, and other well-wishers of the N. P. S., and realized good prices.

The meeting then adjourned, to resume at 2:30 P. M. the following day. The second session was held on July 23d at 75-77 Nassau Street.

President Weiss called the meeting to order at 2:30 P. M. with twenty members present. This session was given up entirely to routine business and the reports of the different officers.

Messrs. Herbert and Heller, were appointed a committee to audit the treasurer's books to date.

Adjournment was then taken to 9:00 P. M.

The third session was called to order by President Weiss, at 9:00 P. M. at the Aschenbroedel Hall with sixty members present.

Reports from Branch #2 of Boston, #3 of New York, #4 of Montclair, N. J. and #5 of Lynn, Mass., were read and showed a flourishing condition.

The following officers were elected for the ensuing year: President, E. L. Clark; 1st Vice-Pres., G. R. Goetz; 2nd Vice-Pres., H. Meyers; Secretary and Treasurer, A. M. Wright; Board of Directors at Large, E. L. Weiss, Chairman; W. C. Polk, J. H. Frederick, M. Herbert, J. E. Guest, W. A. Striker; Appointive Officers, Sales Supt., A. C. Bartley; Exchange Supt., J. S. Swisher; Auction Mgr., M. Ohlman; Counterfeit Detector, E. H. Gammans, Librarian, J. B. Childs; Fraud Investigator, J. E. Guest; Editor of the Official Bulletin, W. C. Polk; International Secretary, O. Hill.

The Constitution and By-Laws were amended to read: "Dues Sixty Cents per year, with Initiation Fee of Twenty Five Cents for each member accepted, to be paid at the beginning of the fiscal year, Sept. 1st."

Another amendment is as follows: "Society to publish its own official organ."

Other amendments were left to the discretion of the Board of Directors.

Lynn, Mass. secured the Convention for 1916, by a vote of seventy-three to sixty-six, Boston being second choice.

The auction sale which followed was a decided success, seventy lots fetching over \$25.00 for the recruiting fund.

After the report of the auditing committee, the meeting adjourned at 1:30 P. M. July 24th.

The fourth and final session of the Convention was held at 75-77 Nassau Street, on July 24th.

Meeting called to order at 2:00 P. M. with the new President, Mr. Clark in the chair and twenty-two members present.

After the adoption of a National Emblem pin, the Convention adjourned sine die to meet in Lynn, Mass. in 1916.

Upon adjournment, the members and visitors became the guests of the New York Philatelic Exchange Society and at 7:00 P. M. the entire party boarded two special cars on the new Fourth Avenue Subway, to Coney Island where a thoroughly good time was had by all.

M. CASPER, Official Reporter.

Southern Philatelic Association.

The Convention of the Southern Philatelic Association was held Aug. 5th, 6th, and 7th at Reading, Pa.

The Convention met on the morning of the 5th at the Hotel Berkshire and an address of welcome was made by Mayor Stratton, to which Mr. Charles Severn responded on behalf of the Association.

After the address by Mr. Clifford W. Kissinger, the President, the Convention call was read by the Secretary, Mr. C. V. Webb, and the Convention got down to business in earnest.

The annual reports were submitted and referred to the proper committees for action.

The Secretary reported a total membership of 1,020 members, an increase of 364 during the past eleven months.

New branches of the association have been organized in Reading, Washington, D. C., Brooklyn, and Perry, Ohio.

The following officers were elected for the ensuing year:

President, C. W. Kissinger of Reading.

Vice-President, William Lycett, of New York City.

Secretary, C. V. Webb, of Perry, Ohio.

Treasurer, Erwin L. Fischer, of Cincinnati, Ohio.

International Secretary, Harry E. Klotzbach of Buffalo.

Sales Manager, J. E. Guest, of Minneapolis, Minn.

Exchange Manager, E. T. Wallis, of Indianapolis.

Auction Manager, M. Ohlman, of New York City.

Attorney, W. E. Scripture, of Rome, N. Y.

Publicity Manager, Rev. L. G. Dorpat, of Wisconsin.

Librarian, W. R. Ricketts, of Forty-Fort, Pa.

Trustees, Robert C. Edgar, W. L. English, Jr., and F. R. Hayworth, all of Kansas, George E. Fiscus and Charles L. Bond, of Indiana.

At the afternoon session there was a lively discussion after the report of the Board of Trustees.

Washington, D. C., was selected as the Convention City for 1916.

The session adjourned at 3:00 o'clock and a photograph of the delegates was taken at the Berkshire which was followed by a trip over the Neversink Mountain R. R.

At 7:30 a public stamp auction was held in the dining room of Kuechler's Roost. Mr. Henry Ades Fowler conducted the sale.

The final session of the Convention was begun at 10:00 o'clock and various questions concerning the Constitution were discussed and reports were read.

The final business of the Convention having been finished, the 21st Annual Convention of the S. P. A. was declared ended.

In the afternoon a motor trip was made over the mountains and other places of interest.

Taken all in all, the Convention was one of the most satisfactory in the history of the Association.

Much publicity was given the Convention in the Reading press and called forth some interesting comments and cartoons.

Wise, the Owl cartoonist, of the "Reading News-Times", of Aug. 5th in addition to several clever cartoons, indited a poem, which we append herewith:

"Th' Stamp of Approval"

Oh, an order philatelic, can derive a joy angelic,
 From a common little ordinary, two-cent stamp.
 It's a fad entirely lawful, with a fascination awful
 When some rare elusive specimen's brot into camp.
 With prices ever changing, and a valuation ranging,
 From a jitney to a hundred bones or not far short—
 From unholy joys protecting, we'd advise you stamp-collecting
 As a safe and sane and sanitary indoor sport.

J. M. BARTELS CO.

beg to announce the publication of the greatly amplified list giving a detailed description of now nearly

400 Specialized Approval Selections.

This pamphlet is a great piece of work in itself and the first of its kind published on anything like such an extensive scale. This wonderful display of fine stamps is made up into separate approval books which hold on the average over 200 each and is marked at attractive prices.

THE STRONGEST SECTION COM-
PRISES NO LESS THAN

100 BOOKS OF U. S. STAMPS

Each Covering a Different Field.

The average collector will wonder how this can be possible, so for his information we will state that the books are divided into groups as follows: Unused, single stamps (23), unused blocks (20), used singles (16), envelopes, cut square (18), Revenues (6), Telegraphs, Proofs, Locals, Carriers, Plate Numbers, etc. make up the balance. Some are prepared for the younger general collector, others for the more advanced specialist.

The other important groups are U. S. Possessions, British Colonials, American Republics, Europe and Various Countries.

The pamphlet giving full information concerning the above is sent free on request and we will continue to call it our **PINK LIST** by which the former unpretentious leaflet was known.

99 Nassau St., New York



Made in America

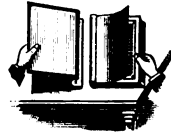

Interchangeable Leaves

BLANK ALBUMS - \$4.00 and up

STOCK BOOKS - \$2.00 and up

Used by the foremost Collectors and Dealers
Complete price list free on request



"No Plus Ultra" Watermark Revealer
Price 50c. Postage 10c. extra

All "No Plus Ultra" supplies manufactured exclusively by
SCOTT STAMP & COIN CO.
127 Madison Ave. New York City

Foreign Revenues.

Whether you collect them or not you need a **REVENUE CATALOGUE**. Very often a revenue stamp worth dollars is thrown away or exchanged for a few cents. **Forbin's Revenue Catalogue** is the only catalogue giving illustrations, descriptions and prices of the revenue stamps of all countries. Price \$1.50. Dealers supplied.

VAHAN MOZIAN,
140 Nassau St., New York City.

Confederates

Locals and Carriers

What have you to offer?

Send at your lowest cash price.

JOHN A. KLEMANN
118 Nassau St. New York

THE PHILATELIC GAZETTE

PUBLISHED MONTHLY FOR STAMP COLLECTORS

VOL. V, No. 9.

NEW YORK, SEPTEMBER, 1915.

WHOLE No. 73.

COPYRIGHT, 1915, BY THE NASSAU STAMP CO.

The United States Government Collection of Postage Stamps.

BY JOSEPH B. LEAVY
Philatelist, U. S. National Museum.

(Continued.)

AUSTRIAN ITALY.

- 1861, REPRINTS of 1865, 2sld yellow, 3sld green, 5sld red, 10sld brown, 15sld deep blue, perforated 12.
Of 1871, 5sld red, 10sld brown, perforated 10½.
1863, 2s yellow, 3s green, 5s rose, 10s blue, 15s yellow brown, perf. 14.; 2s yellow, 3s green, 5s rose, 10s blue, 15s yellow brown, perf. 9½.
REPRINTS of 1889, 2s yellow, 3s green, perforated 10½.

HUNGARY

- 1871, lithographed, 2kr orange, 3kr light green, 5kr rose, 10kr blue, 15kr yellow brown, 25kr bright violet (used).
1872, engraved, 2kr yellow, 3kr green, 5kr rose, 10kr blue, 15kr brown, 25kr lilac.
REPRINTS, 2kr yellow, 3kr green, 5kr carmine, 10kr blue, 15kr brown, 25kr lilac.
1874-76, no watermark, 2kr lilac, 2kr violet (used), 2kr rose lilac (used), 3kr yellow green, 3kr green (used), 3kr blue green (used), 5kr red, 5kr carmine (used), 5kr rose (used), 10kr blue, 10kr deep blue (used), 20kr slate.
1881, watermarked kr in circle, 2kr violet, 2kr mauve, 3kr yellow green, 3kr green (used), 3kr blue green (used), 5kr carmine, 10kr blue, 10kr deep blue (used), 20kr slate, 20kr gray; 20kr slate, retouched at top (used); 20kr slate, retouched at bottom (used).
1885, new plates, 2kr violet, 3kr green, 10kr blue.
1888-91, 1kr black, 1kr gray black, 5kr rose, 5kr pale rose, 8kr orange, 8kr yellow, 12kr brown and green, 12kr pale brown and green, 15kr claret and blue, 15kr claret and pale blue, 24kr brown and violet, 24kr red brown and violet, 24kr pale brown and violet, 30kr olive and brown, 30kr olive green and brown, 30kr olive and pale brown, 50kr red and orange, 50kr red and orange yellow, 50kr vermilion and orange, 1f gray blue and silver, 1f gray and silver, 1f slate and silver, 3f lilac brown and gold, 3f violet brown and gold.
1898, 20kr gray.
1898-99, watermarked crown in circle, 1kr black, 2kr violet, 3kr green, 5kr rose, 10kr blue, 20kr gray.
1900, 1f gray, 1f dull lilac, 2f olive yellow, 3f orange, 3f yellow, 4f violet, 4f deep violet, 5f emerald green, 5f green, 6f claret, 6f violet brown, 10f carmine, 10f pale carmine, 25f blue, 25f dull blue, 30f orange, 50f lake, 60f gray green, 60f olive, 1k brown red, 3k sea green.

- 1901, 6f bistre, 6f olive green (used), 20f brown, 35f red violet, 2k gray blue, 5k violet brown.
 1904, 12f violet.
 Newspaper stamps, 1871, (1kr) vermilion.
 1872, (1kr) rose red.
 1874, no watermark, 1kr orange.
 1877, watermarked kr in circle, 1kr orange, 1kr yellow, 1kr red orange.
 1900, (2f) red orange in a pair.
 Postage due, 1903, 1f, 2f, 5f, 6f, 10f, 12f, 20f, 50f, 100f, green and black.

BOSNIA

- 1879-94, early plates, fine impression, 1n gray, 1n pearl gray, 1n deep gray, 2n yellow, type I, 2n yellow orange, type I, 2n orange, type I, 3n green, 3n deep green, 3n dull green, 3n blue green, 3n yellow green, 3n dark green, 5n rose red, type I, 5n red, type I, 5n vermilion, type I, 10n blue, type I, 10n deep blue, type I (used), 10n dark blue, type I (used), 10n slate blue, type I (used), 10n dull blue, type I (used), 10n gray blue, type I (used), 15n bistre, type I, 15n yellow brown, type I (used), 20n gray green, 25n violet, 25n red lilac.
 1879-94, late plates, coarse impression, $\frac{1}{2}$ n black, type I, $\frac{1}{2}$ n black, type II, $\frac{1}{2}$ n black type III (used), 1n gray, 1n pale gray, 1n light gray, 2n orange, type II, 2n yellow orange, type II (used), 2n deep orange, type II (used), 3n green (used), 3n dull green (used), 3n deep green (used), 5n red, type II (used), 5n vermilion, type II (used), 10n blue, type II (used), 10n slate blue, type II (used), 15n brown, type II (used), 20n gray green, 20n olive green.
 1888-89, 5n red, type III, (used), 5n vermilion, type III (used).
 1900, 1h black, 1h gray black, 2h gray, 3h yellow, 5h green, 6h brown, 10h red, 10h rose red, 20h rose, 25h blue, 30h bistre brown, 40h orange, 50h red lilac, 1k dark rose, 2k ultramarine, 5k dull blue green.
 1901-04, 20h pink, 30h bistre brown, 35h ultramarine, 40h orange, 45h greenish blue.
 1906, 1h black, 2h violet, 3h olive, 5h dark green, 6h brown, 10h carmine, 20h dark brown, 25h deep blue, 30h green, 35h myrtle green, 40h orange red, 45h brown red, 50h dull violet, 1k maroon, 2k bronze green, 5k dull blue.
 1912, 1h olive green, 2h bright blue, 3h claret, 5h green, 6h dark gray, 10h rose carmine, 12h ultramarine, 12h deep olive green, 20h orange brown, 25h ultramarine, 30h orange red, 35h myrtle green, 40h dark violet, 45h olive brown, 50h slate, 60h dull blue, 60h brown violet, 72h carmine, 72h dark blue, 1k brown violet, on straw, 2k dark gray on blue, 3k carmine on green, 5k dark violet on gray.
 1914, 10k deep blue on gray.
 Postage due, 1904, 1h, 2h, 3h, 4h, 5h, 6h, 7h, 8h, 10h, 15h, 20h, 50h, black, red and yellow, 200h black, red and green.

BELGIUM

- 1849, 10c brown, 10c reddish brown, 20c blue, 20c deep blue, all used.
 REPRINTS of 1866, thick laid paper, 10c brown, 20c blue.
 Of 1898, thin wove paper, 10c brown, 20c blue.
 1850, framed watermark, thin paper, 20c blue, used.
 Medium paper, 10c brown, 20c blue, 40c carmine, all used.
 1851, watermark without frame, thin paper, 10c brown, 20c blue, 20c dull blue, all used.
 Medium paper, 10c brown, 20c blue, 20c dull blue, all used.
 Thick paper, 10c brown, 20c blue, 20c dull blue, 40c dull red, all used.
 1861, no watermark, short oval, 10c brown, 10c gray brown, 20c blue, 20c deep blue, all used.
 Long oval, 1c green, 10c brown, 10c gray brown, 20c blue, 40c vermilion.
 1863, perforated $12\frac{1}{2}$ by $13\frac{1}{2}$, long oval, 10c brown, 20c blue, both used.
 Perforated $12\frac{1}{2}$ by $13\frac{1}{2}$, short oval, 10c brown, 10c gray brown (used), 20c blue, 20c deep blue (used), 40c carmine rose.

- Perforated 14½, short oval, 1c green, 1c pale green, 10c brown (used), 20c blue, 20c bright blue, 40c carmine rose.
- 1865, London print, perforated 14, 1fr pale violet.
- 1866, Brussels print, perforated 14½ by 14, 1c gray, 2c ultramarine, 5c brown, 10c slate, 10c slate gray, 20c light blue, 30c brown, 40c rose.
- 1867, Malines print, perforated 15, 2c ultramarine, 5c brown, 20c ultramarine, 40c rose.
- 1869-80, thick paper, perforated 15, 1c green, 1c yellow green, 2c ultramarine, 2c pale ultramarine, 5c buff, 5c pale buff, 8c lilac, 8c dull violet, 10c green, 20c light ultramarine, 30c buff, 40c pale rose, 1fr violet, 1fr deep violet.
- 1869-80, thin paper, perforated 15, 10c deep green, 20c gray blue, 40c bright rose, 40c rose carmine.
- 1875-78, thick paper, perforated 15, 25c bistre, 25c olive bistre, 50c gray, 50c slate gray, 50c gray black, 5fr pale brown.
- 1881, aniline ink, perforated 15, 1c dark gray green.
- 1883, 10c carmine, 20c gray.
- 1884-85, 1c gray, 1c slate gray, 5c green, 10c rose on bluish, 10c carmine on gray, 25c blue on pink, 25c blue on rose, 25c dull blue on rose, 1fr brown on greenish, 1fr red brown on greenish.
- 1886-91, 2c purple brown, 20c olive, 20c reseda, 20c olive green, 35c violet brown, 35c purple brown, 50c bistre, 50c olive bistre, 2fr violet, 2fr pale violet.
- 1893, 1c gray, 2c yellow, 5c green, 5c yellow green, 10c orange brown, 20c reseda, 25c ultramarine, 35c brown, 35c violet brown, 50c bistre, 1fr carmine on greenish, 1fr deep rose on greenish, 2fr lilac on rose, 2fr deep lilac on rose.
- 1894, Antwerp exhibition, 5c green on pink, 5c green on rose, 10c carmine on bluish, 10c carmine on gray, 25c blue on rose, 25c dull blue on rose.
- 1896-97, Brussels exhibition, 5c deep violet, 10c orange brown, 10c lilac brown, 10c violet brown.
- 1898, 2c red brown, 50c gray, 50c slate.
- 1900, 10c bright rose, 10c dull rose, 1fr orange, 1fr orange yellow, 2fr lilac, 2fr pale lilac.
- 1905-07, 10c dull rose, 20c olive, 25c ultramarine, 35c purple brown, 50c gray, 1fr orange, 2fr violet.
- 1912, 1c orange, 2c orange brown, 5c green, 10c red, 20c olive, 35c bistre brown, 40c green, 50c gray, 1fr orange, 2fr violet, 5fr plum.
- 1912, large head, 25c ultramarine.
- Charity stamps, 1910, type I, 5c peacock blue, 10c red brown.
Type II, 1c gray green, 2c violet brown.
- Red Cross stamps, 1914, small king's head, 5c green, 10c red, 20c lilac; large stamp, 5c green, 10c red, 20c lilac.
1915, large king's head, 5c green and red, 10c carmine and red, 20c purple and red.
- Postage due, 1870, thick paper, 10c green, 10c deep green, 20c ultramarine.
Thin paper, 20c ultramarine, 20c dull blue.
1895, 5c green, 5c yellow green, 10c orange brown, 20c olive, 50c yellow brown, 1fr carmine.
1900, 10c carmine, 50c gray, 1fr ochre.
1909, 30c pale blue.
- Postal Packet stamps, 1879-82, 10c violet brown, 20c blue, 25c green, 25c yellow green, 50c carmine, 80c yellow, 1fr gray, all used.
1882-94, 10c brown, 10c red brown, 10c dull brown, 10c pale brown, 15c gray, 20c ultramarine, 20c pale ultramarine, 20c blue, 25c blue green, 25c yellow green, 50c carmine, 50c dull carmine, 50c rose, 80c lemon, 1fr lavender, 1fr dull lavender, 1fr lilac brown, 2fr yellow buff, all used.
1895-98, 10c red brown and black, 10c brown and black, 15c gray and black, 20c blue and black, 20c dull blue and black, 25c green and black, 25c blue green and black, 50c carmine and black, 50c rose and black, 60c violet and black, 60c deep lilac and black, 60c lilac and black, 80c olive yellow and black, 1fr lilac brown, 1fr violet brown, 1fr purple brown, 2fr buff, 2fr yellow buff, all used.

- 1882-94, aniline ink, 10c red brown, 20c dull blue, 50c aniline rose, 80c olive yellow, all used.
 1895, aniline ink, 10c red brown and black, 20c dull blue and black, 50c aniline rose and black, 80c olive yellow and black, all used.
 1902, 30c orange and black, 40c green and black, 70c blue and black, 90c red and black, all used.
 1902-06, 10c yellow brown and slate, 20c ultramarine and yellow brown, 20c dull blue and yellow brown, 25c yellow green and red, 30c orange and blue green, 40c blue green and violet, 50c rose and violet, 60c violet and red, 60c lilac and red, 70c blue and red, 80c lemon and violet brown, 90c red and yellow, 1fr violet brown and orange, 1fr 10c rose and gray, 2fr ochre and blue green, 3fr black and ultramarine, all used.

BELGIAN CONGO

- 1886, 5c green, 5c yellow green, 10c rose, 10c carmine, 25c blue, 25c dull blue, 50c reseda, 50c olive, 5fr lilac.
 1887, 50c brown, 50c gray brown, 5fr violet (specimen).
 1888-94, 5c green, 5c yellow green, 5c blue green, 10c rose, 10c carmine, 25c blue, 25c dull blue, 5fr gray, 10fr buff, 10fr yellow buff.
 1894, 5c pale blue and black, 10c red brown and black, 25c yellow orange and black, 25c brown orange and black, 50c green and black, 50c blue green and black, 1fr lilac and black, 1fr rose lilac and black, 5fr lake and black.
 1895, 5c red brown and black, 10c greenish blue and black.
 1896, 15c ochre and black, 40c bluish green and black, 40c greenish blue and black.
 1898, 3fr50c red and black, 10fr yellow green and black.
 1900, 5c green and black, 10c carmine and black, 25c light blue and black, 50c olive and black.
 1908, overprint typographed, 5c green and black, 10c carmine and black, 15c ochre and black, 25c light blue and black, 40c bluish green and black, 50c olive and black, 1fr carmine and black, 3fr50c red and black, 5fr carmine and black, 10fr yellow green and black.
 1908, overprint handstamped, 5c green and black, 10c carmine and black, 15c ochre and black, 25c light blue and black, 40c bluish green and black, 50c olive and black, 1fr carmine and black, 3fr50c red and black, 5fr carmine and black, 10fr yellow green and black.
 1909, 5c green and black, 10c carmine and black, 15c ochre and black, 50c olive and black.
 1910, 5c green and black, 10c carmine and black, 15c ochre and black, 25c blue and black, 40c bluish green and black, 50c olive and black, 1fr carmine and black, 3fr red and black, 5fr carmine and black, 10fr green and black.
 Postal Packet stamps, 1888, 3fr50c on 5fr violet.
 1893, 3fr50c on 5fr gray.

BOLIVIA

- 1866-67, 5c green, 5c deep green, 10c brown (used), 50c orange, 100c blue.
 1869, 5c green, 10c vermilion, 50c blue, 100c orange, 500c black.
 1871, 5c green, 10c vermilion, 50c blue (used), 100c orange.
 1878, 10c orange, 20c green, 50c dull carmine.
 1887, 1c rose, 2c violet, 5c blue, 10c orange.
 1890, 1c rose, 2c violet, 5c blue, 10c orange, 20c dark green, 50c red, 100c yellow.
 1894, 1c yellow bistre, 2c vermilion, 5c yellow green, 10c yellow brown, 10c bistre brown, 20c slate blue, 20c dark blue, 50c brown violet, 50c dull red violet.
 1897, 1c pale yellow green, 2c red, 2c vermilion, 2c pale vermilion, 5c dark green, 10c brown violet, 20c lake and black, 50c orange, 50c yellow, 1b Prussian blue, 2b red, yellow, green and black.
 1899, provisional, 1c yellow bistre, 2c red orange, 5c green, 10c yellow brown, 20c dark blue.

- 1899, 1c gray blue, 1c pale gray blue, 2c brownish red, 5c dark green, 10c yellow orange, 10c yellow, 20c rose pink, 50c bistre brown, 1b gray violet.
 1901, 5c dark red.
 1901-02, 1c claret, 2c green, 5c scarlet, 10c blue, 20c violet and black, 2b brown.
 1909, 1c light brown and black, 2c green and black, 5c red and black, 10c dull blue and black, 20c violet and black, 50c olive bistre and black, 1b gray brown and black, 2b chocolate and black.
 1910, 5c green and black, 10c claret and indigo, 20c dull blue and indigo.
 1911, 5c on 2c green.
 1912, provisional, 2c green, 5c orange, 10c vermilion, 10c on 1c blue.
 1913, 1c carmine rose, 2c vermilion, 5c green, 8c yellow, 10c gray, 20c deep violet and black, 50c dull violet, 1b slate blue, 2b black.
 (To be continued.)

THE POSTAL ISSUES OF AUSTRIA.

BY J. BRACE CHITTENDEN, Ph. D.

(Continued.)

ELEVENTH ISSUE.

From Dec. 1st. 1899 until Oct. 31st. 1908.

Similar in every respect to the last three issues with Heller instead of Kreuzer and Kronen instead of Gulden. Values 1 to 60H. and 1 to 4 Kronen like the eighth issue, the 40, 50, and 60H like the ninth issue with a change in the 10, 20, 25 and 30 to the ninth issue type with squares in the corners instead of hexagons. No watermark. Perforation 10½ to 13½. Paper without varnish stripes.

TABLE 32 (KOHLE)

| | A | | B | | C | | D | | E | |
|---------------------------|-----------|-----|-------|------|--------|-------|--------|------|--------|------|
| | P. 13:12½ | | P.12½ | | P. 10½ | | P.10½: | | P.12½: | |
| | P. 13:13½ | | | | | | 12½ | | 10½ | |
| 1H. pale lilac } | | | | | | | | | | |
| 1H. dark lilac } | .08 | .01 | .12 | .05 | 7.50 | 2.50 | — | 5.00 | — | 2.50 |
| 2H. black } | | | | | | | | | | |
| 2H. gray } | .01 | .01 | .12 | .02 | .62 | .12 | 5.00 | 1.25 | 5.00 | .50 |
| 3H. light brown } | | | | | | | | | | |
| 3H. yellow brown } | .01 | .01 | .12 | .04 | 1.25 | .18 | — | 5.00 | — | 2.50 |
| 5H. blue green } | | | | | | | | | | |
| 5H. pale green } | .01 | .01 | — | .50 | 2.50 | 1.25 | — | 1.85 | — | .62 |
| 6H. red orange } | | | | | | | | | | |
| 6H. yellow orange } | .02 | .01 | .22 | .05 | .35 | .04 | — | 3.75 | — | 2.00 |
| 10H. carmine rose } | | | | | | | | | | |
| 10H. rose } | .03 | .01 | — | 1.25 | — | 10.00 | — | — | — | — |
| 20H. gray brown } | | | | | | | | | | |
| 20H. dark brown } | .06 | .01 | .25 | .06 | 1.00 | .12 | — | 2.00 | — | 1.50 |
| 25H. light ultramarine } | | | | | | | | | | |
| 25H. dark ultramarine } | .08 | .01 | .25 | .02 | .62 | .05 | — | 3.75 | — | 1.25 |
| 30H. light red lilac } | | | | | | | | | | |
| 30H. dark red lilac } | .09 | .02 | .25 | .05 | .85 | .10 | 10.00 | .62 | 7.50 | 1.50 |
| 40H. light green } | | | | | | | | | | |
| 40H. dark green } | .11 | .02 | .25 | .08 | .75 | .25 | — | 3.75 | — | 3.00 |
| 50H. gray blue } | | | | | | | | | | |
| 50H. dark blue } | .15 | .02 | .37 | .25 | .75 | .10 | 2.50 | .50 | 5.00 | 1.00 |
| 60H. red brown } | | | | | | | | | | |
| 60H. dark brown } | .18 | .01 | .50 | .25 | 20.00 | .25 | — | 1.00 | — | 2.00 |
| 1K. carmine rose } | | | | | | | | | | |
| 1K. bluish carmine rose } | .30 | .01 | .30 | .01 | 1.25 | .12 | — | 2.00 | — | 1.00 |
| 2K. gray lilac } | | | | | | | | | | |
| 2K. dark gray lilac } | .62 | .02 | .62 | .02 | 1.85 | .09 | — | 3.75 | — | 2.00 |
| 4K. sea green } | | | | | | | | | | |
| 4K. dark sea green } | 1.12 | .15 | 1.12 | .20 | 2.00 | .25 | — | 5.00 | — | 5.00 |

The 1, 3, 5 and 25H. first appeared in 1899 and the others followed as the exhaustion of the old issues occurred.

TABLE 33.
PERFORATIONS. (Kropf).
1899-1908.

| Perfs. | Heller Values. | | | | | | | | | | | | Kroner. | | |
|----------------|----------------|---|---|---|---|----|----|----|----|----|----|----|---------|----|-----|
| | 1 | 2 | 3 | 5 | 6 | 10 | 20 | 25 | 30 | 40 | 50 | 60 | I | II | IV. |
| 9½:12½ | | | | | | | | | | | | | | II | — |
| 10½ | 1 | 2 | 3 | 5 | 6 | 10 | 20 | 25 | 30 | 40 | 50 | 60 | I | II | IV |
| 10½:12½ | 1 | 2 | 3 | 5 | 6 | | 20 | | 30 | | 50 | 60 | | | IV |
| 10½:13½ | | | | 5 | | | | | 30 | | | | | | |
| 12½ | 1 | 2 | 3 | 5 | 6 | 10 | 20 | 25 | 30 | 40 | 50 | 60 | I | II | IV |
| 12½:10½ | | 2 | | 5 | | | 20 | 25 | 30 | 40 | 50 | 60 | I | II | IV |
| 12½:13½ | | | | | | | | | | 40 | | | | | |
| 13 | | | 3 | | | | | | | 40 | | | | | |
| 13:10½ | 1 | 2 | 3 | 5 | 6 | | | | | | | 60 | | | |
| 13½:12½ (reg.) | 1 | 2 | 3 | 5 | 6 | 10 | 20 | 25 | 30 | 40 | 50 | 60 | | | |
| 13:13½ (reg.) | 1 | 2 | 3 | 5 | 6 | 10 | 20 | 25 | 30 | 40 | 50 | 60 | | | |

NOTE I. Herr Kropf gives several cases of mixed perforations other than those listed above, in particular the 2K. (9½:12½), but Kohl (1915) declares all others than those given in the above table to be counterfeits mentioning in particular 10½, 11½ and compounds with perf. 14 and all mixed or one sided perforations. Those in Column A, Table 32, are regular and made with the complete perforating machine. The compounds D and E are not easily obtained in this country for Scott lists all perforations at the same price and the dealers are too busy to look for them. After you have searched for them about a year or two with varying success the prices listed by Kohl will look reasonable, to say the least. The 10H. (10½) and the 4K. (10½:12½) are very scarce. Examples may also be found with a double perforation. The 1H. and 60H. are mentioned (Philatelist 1908 P. 141) as having been rouletted and the 1, 2, 10, 40, 50, 60H. and 2 and 4K. come imperforated. The French catalogue mentions only the 1H. imperf. as worth (7.00—6.00). Pairs imperf. between either horizontally or vertically exist as follows:

| | | | |
|-----|------|-------|---|
| 67. | 30H. | 25.00 | — |
| 70. | 60H. | — | — |
| 71. | 1K. | 6.25 | — |
| 72. | 2K. | 25.00 | — |
| 73. | 4K. | — | — |

I should consider the imperfs. as printers waste unless postally cancelled and likewise the many cases of faulty printing listed by Kropf as in the preceding issues, except that sets can be made showing poor centering of the figures in the corners. Kohl lists the following varieties as having been used.

| | | | |
|------|---|-------|------|
| 1H. | Figures of value inverted | 12.50 | — |
| 1H. | Figures shifted toward the bottom | — | — |
| 2H. | Right half printed, left half blank | 6.25 | — |
| 2H. | Figures shifted toward top, bottom or left | .75 | — |
| 3H. | Figures lacking | — | — |
| 3H. | Figures shifted toward top, bottom or left | — | 75 |
| 6H. | Figures shifted toward top, bottom or left | 1.00 | 1.00 |
| 10H. | Figures lacking | — | — |
| 20H. | Right half printed, left half blank or vice versa | 6.25 | — |
| 25H. | Figures defective | 3.00 | — |
| 25H. | Figures shifted toward the bottom | — | — |
| 25H. | Figures at left only 6m.m. apart | 12.50 | — |
| 30H. | Figures shifted toward the left or right | 1.00 | — |
| 60H. | Without figures | — | — |

TWELFTH ISSUE.

From June 1901 to Oct. 31, 1908.

Like the eleventh issue in every respect but with the addition of diagonal bars of yellow varnish from 3 to 7 m.m. wide across the face of the stamps.

TABLE 34.

| | | A. (Reg.) | | B. | | C. Comp. | |
|----|------------------|------------|-----|---------|------|------------|------|
| | | P. 13:12 ½ | | P. 10 ½ | | P. 13:10 ½ | |
| | | P. 13:13 ½ | | | | | |
| 74 | 1H. Lilac | .03 | .02 | 15.00 | | — | 2.50 |
| 75 | 2H. Black brown | .01 | .01 | — | — | — | 1.25 |
| 76 | 3H. Brown | .01 | .01 | 15.00 | | — | 2.50 |
| 77 | 5H. Dark green | .02 | .01 | 12.50 | 1.50 | — | 1.85 |
| 78 | 6H. Orange | .02 | .01 | | | — | 2.50 |
| 79 | 10H. Rose | .03 | .01 | 10.00 | 3.75 | — | 2.50 |
| 80 | 20H. Gray brown | .06 | .01 | | | — | 1.85 |
| 81 | 25H. Ultramarine | .08 | .01 | | | — | 1.85 |
| 82 | 30H. Red lilac | .09 | .01 | | | — | 1.85 |
| 83 | 40H Green | .11 | .03 | | | — | 5.00 |
| 84 | 50H. Light blue | .15 | .03 | | | — | 3.75 |
| 85 | 60H. Brown | .18 | .02 | | | — | 2.50 |

NOTE 1. Perforation C. comes three sides close and one side wide (10 ½); the 2 and 10H. are known with perforation 9 ¼, the latter very scarce; the 2 H. with perforation 9 ¼ is worth about \$15.00 unused; the 30 H. comes with perforation 10 ½-12 ½. Kohl thinks that the very scarce perforation 9 ¼ in the issue 1901-1907 were never sold to the public but they are known used as great rarities. The 10 H. is known in red lilac, (error of color) and is very scarce. Kropf's table of perforations agrees in this issue with that of Kohl.

NOTE 2. The effect of the bands of varnish is that the cancellation ink enters the paper between them only and makes obliteration or washing very difficult. From the standpoint of the collector it causes a cancelled set on the average to look miserable in the extreme. As before remarked, good cancelled specimens, well centered, in any issue of Austria are deserving of respect and to find them in good condition is an honorable achievement. Herr Fratcel (Ill. Briefmarken Journal) affords the following opportunity to ruin one's eyesight.

Variety 1. Width of bands 3mm; space between bands 10mm.

Variety 2. Width of bands 5mm; space between bands 9mm.

Variety 3. Width of bands 7mm; space between bands 6mm.

Variety 3 is the rarest, being the same as the essays in the Kreuzer issue; Variety 1 was used last and is the most common.

THIRTEENTH ISSUE.

From Feb. 1902 until Oct. 31, 1908.

A new value, introduced to meet the demands of Registered letters formerly requiring two stamps at least.

TABLE 35.

| | | A | | B | | C | |
|----|-----------------|------------|-----|------------|------|---------|--|
| | | P. 13:12 ½ | | P. 13:10 ½ | | P. 12 ½ | |
| | | P. 13:13 ½ | | | | | |
| 86 | 35K. Dark green | .10 | .01 | — | 3.75 | | |

NOTE 1. In all values in the last two issues badly centered figures of value may be found, as well as other faulty printing, of which the following have done postal service.

| | | | |
|-------|--|------|------|
| 6 H. | Right half of stamp printed, left half white | 6.25 | — |
| 10 H. | Figures defective | — | 6.25 |
| 60 H. | No figures of value | — | — |
| 60 H. | Some of the figures lacking | — | — |

(To be continued.)

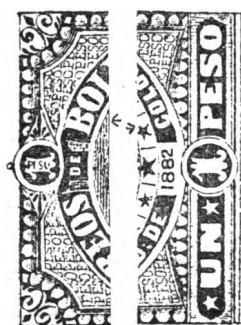

T.1

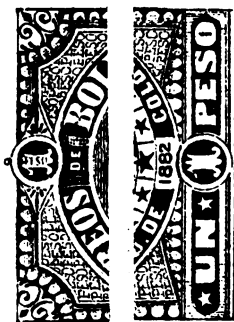

T.2



T.1



T.2

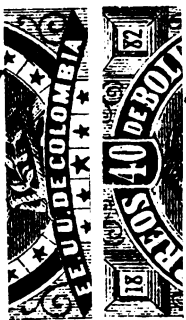

T.1



T.1



T.2



T.1



T.2



T.1



T.2

PLATE VII.

BOLIVAR.**The Stamps of 1879-1899.**

By A. HATFIELD, JR., and BERTRAM W. H. POOLE.

(Continued.)

VI.—The 1882 Issue.

About the time of the appearance of the large 5 and 10 pesos stamps a new issue of the lower values was made though there can hardly have been any necessity for a change considering the same portrait was retained and the same colors were used. The "Philatelic Record" for December, 1882, mentioned the receipt of the new set "consisting of six values, all of which differ the one from the other, except as regards the central portrait of the immortal Liberator, on a ground of horizontal lines, which is common to each. The circular frame around the portrait is the same in all the values except the 40 centavos. The upper curve is inscribed CORREOS DE BOLIVAR, in white Roman capitals on color, and the lower one is divided into two bands, the lower one of color inscribed in white block letters EE. UU. DE 1882 COLOMBIA, and the upper one white, with nine colored stars. The upper and lower legends are separated by a shield on either side, blazoned with the Arms of the State. In the centre, above and below the circle, are cartouches, differing in shape for each value, containing the numerals of value on colored ground. Ornamental scrolls and labels at the bottom of each stamp are inscribed with the value in full, and the decoration of the borders and spandrels of each value is different. The 40 centavos is somewhat differently arranged from the others, and has the additional inscription CERTIFICADA in a straight label at the bottom."

The only correction we have to make to the above is with regard to the date "1882". This is in colored numerals on a white tablet in each case.

All six values were printed from lithographic stones in sheets of fifty, arranged in five horizontal rows of ten stamps each. The lithographic stones in each instance were made up from two transfers differing from one another in small particulars, so that we have two minor types of each denomination. These types were arranged in a most haphazard fashion as we shall show by diagrams illustrating the settings of each value.

The 5 centavos.

The two types of this value may be distinguished by the following peculiarities:—

- Type 1. The right lower point of the star above the C of COLOMBIA is elongated and touches the color below.
 Type 2. There is a small colored dot on the S of CORREOS, another on the vertical stroke of the L of COLOMBIA near the top of the letter, and there are colored dots within both curves of the S of CENTAVOS and also one under that letter.

The types are distributed on the sheet in the following curious manner:

| | | | | | | | | | |
|---|---|---|---|---|---|---|---|---|---|
| 1 | 1 | 2 | 1 | 1 | 2 | 1 | 2 | 1 | 1 |
| 2 | 2 | 1 | 2 | 2 | 1 | 1 | 2 | 2 | 1 |
| 1 | 1 | 2 | 1 | 2 | 1 | 1 | 1 | 2 | 1 |
| 2 | 1 | 2 | 2 | 1 | 2 | 2 | 1 | 2 | 1 |
| 2 | 2 | 2 | 1 | 2 | 2 | 2 | 2 | 1 | 2 |

It will be noted that there are 24 specimens of type 1 and 26 of type 2 on each sheet.

The 10 centavos.

The distinguishing points of the two types of this value are:—

Type 1.—A colored dash is shown in the space occupied by the star above the C of COLOMBIA. This dash is close to the space line to the left of the star and it extends diagonally upwards to the right.

Type 2.—The end of the nose has a luminous effect but the easiest test for this variety is the absence of the mark distinguishing type 1.

The types are arranged on the sheet as follows:—

| | | | | | | | | | |
|---|---|---|---|---|---|---|---|---|---|
| 1 | 2 | 1 | 2 | 1 | 2 | 1 | 1 | 2 | 1 |
| 2 | 1 | 1 | 2 | 2 | 1 | 1 | 2 | 2 | 1 |
| 1 | 2 | 2 | 2 | 1 | 1 | 2 | 1 | 1 | 2 |
| 1 | 2 | 2 | 2 | 2 | 2 | 1 | 1 | 2 | 1 |
| 1 | 2 | 2 | 1 | 1 | 1 | 2 | 1 | 2 | 1 |

In this case there are 26 specimens of type 1 and 24 of type 2 on each sheet.

The 20 centavos.

The two types of this value are readily distinguished by the following small characteristics:—

Type 1.—There is a small colored dot $\frac{1}{2}$ mm outside the right frame line opposite the middle of the shield.

Type 2.—The outer line of the left hand shield is broken in the centre.

The sheet arrangement of the types is as follows:—

| | | | | | | | | | |
|---|---|---|---|---|---|---|---|---|---|
| 1 | 1 | 2 | 1 | 2 | 1 | 1 | 1 | 1 | 2 |
| 1 | 2 | 2 | 2 | 1 | 2 | 1 | 2 | 1 | 1 |
| 1 | 1 | 2 | 2 | 1 | 2 | 2 | 2 | 2 | 1 |
| 1 | 2 | 2 | 2 | 2 | 2 | 1 | 2 | 2 | 2 |
| 1 | 1 | 1 | 1 | 1 | 2 | 2 | 2 | 2 | 1 |

The sheet, therefore, shows a total of 24 stamps of type 1 and 26 of type 2.

The 40 centavos.

The two types are as follows:—

Type 1.—A colored line extends from the lower right ray of the lower star at right and crosses the dividing line into the solid band of color. There is a colored dot on the upright stroke of the B of BOLIVAR, just below the centre, close to and sometimes cutting into the solid background.

Type 2.—This can be at once told from the absence of the small marks distinguishing type 1.

The two types are distributed on the sheet in the following manner:—

| | | | | | | | | | |
|---|---|---|---|---|---|---|---|---|---|
| 1 | 2 | 1 | 2 | 1 | 2 | 2 | 2 | 2 | 1 |
| 1 | 2 | 1 | 2 | 2 | 1 | 1 | 1 | 1 | 2 |
| 2 | 1 | 2 | 1 | 1 | 1 | 2 | 2 | 2 | 2 |
| 1 | 2 | 2 | 2 | 1 | 1 | 1 | 1 | 2 | 1 |
| 2 | 1 | 1 | 2 | 2 | 2 | 1 | 2 | 1 | 1 |

Though there is apparently an entire lack of method of arrangement as in the case of the other denominations, there are exactly 25 specimens of each type on the sheet.

The 80 centavos.

The two types of the 80c may be distinguished by the following peculiarities:—

- Type 1.—There is a small colored dot on the “0” of “80” at the top.
 Type 2.—There is a colored dot on the white line above the second R of CORREOS; and a larger dot is shown on the shading to the right of the numerals “80” at top.

The following diagram shows how the types are distributed on the sheets:—

| | | | | | | | | | |
|---|---|---|---|---|---|---|---|---|---|
| 1 | 2 | 2 | 1 | 1 | 2 | 1 | 2 | 1 | 2 |
| 1 | 1 | 1 | 2 | 2 | 1 | 1 | 1 | 1 | 2 |
| 1 | 1 | 2 | 2 | 1 | 1 | 2 | 1 | 2 | 1 |
| 2 | 2 | 2 | 1 | 2 | 2 | 2 | 2 | 1 | 1 |
| 1 | 2 | 1 | 2 | 2 | 2 | 2 | 1 | 1 | 1 |

In this value there are 26 specimens of type 1 on each sheet and 24 of type 2.

The 1 peso.

The two types of the 1 peso are as follows:—

Type 1.—The top of the B of BOLIVAR is divided from the uncolored line above it by a very thin line of color which is often broken so that in some cases the B and line are joined. The same applies to the C of COLOMBIA in relation to the uncolored line below that letter.

Type 2.—In each case the colored space or line dividing the B of BOLIVAR and C of COLOMBIA from the uncolored lines is wider.

The sheet arrangement of the types is as shown below:—

| | | | | | | | | | |
|---|---|---|---|---|---|---|---|---|---|
| 1 | 1 | 1 | 1 | 2 | 1 | 1 | 1 | 1 | 1 |
| 1 | 2 | 2 | 2 | 2 | 2 | 2 | 2 | 1 | 2 |
| 1 | 2 | 1 | 2 | 1 | 2 | 1 | 1 | 1 | 1 |
| 2 | 2 | 1 | 1 | 2 | 2 | 2 | 1 | 1 | 1 |
| 2 | 2 | 2 | 2 | 1 | 2 | 1 | 2 | 2 | 1 |

In each sheet, therefore, there are 26 specimens of type 1 and 24 of type 2.

Paper.

All the stamps of this set were printed on ordinary white wove paper.

Perforation.

All six values are known perforated 12 all round and also perf. 16 by 12. The perforation of both gauges was the work of single line machines. Whether both varieties were in use at the same time or not we cannot say positively but it is interesting to note that in the original chronicle in the “Philatelic Record” the perforation is described as “12x16” whereas in the “Monthly Journal” for May and June, 1894, the compound perforations are mentioned as curious novelties. The 20c, perf. 16x12, is known in horizontal pairs imperforate between.

Imperforate varieties.

All values with the exception of the 40c are known entirely imperforate and we have seen sheets, fully gummed, in this condition. As in the case of the similar varieties of the earlier issues these can best be described as unfinished stamps.

(To be continued.)



Published the 15th day of each month

J. KLEMMANN, Jr., Editor.

CLIFTON A. HOWES, Special Contributing Editor.

JOHN A. KLEMMANN, Managing Editor.

Staff Writers.

CHARLES LATHROP PACK

VICTOR M. BERTHOLD

J. MURRAY BARTELS

DR. CARROLL CHASE

A. E. OWEN

W. B. SPRAGUE

B. W. H. POOLE

VAN DYK MacBRIDE

SUBSCRIPTION \$1.00 A YEAR, SINGLE NUMBERS 10c.

Advertising Rates

| | 1 mo. | 3 mos. | 6 mos. | 9 mos. | 12 mos. |
|--------------|--------|--------|--------|---------|---------|
| 1 inch | \$1.50 | \$4.00 | \$7.75 | \$11.50 | \$15.00 |
| ¼ p. | 5.00 | 13.50 | 26.25 | 38.00 | 50.00 |
| ½ p. | 8.50 | 23.00 | 44.50 | 65.00 | 85.00 |
| 1 page | 15.00 | 40.50 | 78.75 | 114.75 | 150.00 |

NASSAU STAMP CO., Publishers, 118 NASSAU ST., NEW YORK.

VOL. V, No. 9.

NEW YORK, SEPTEMBER, 1915.

WHOLE No. 73.

EDITORIAL.

On another page will be found an advertisement of the Belgian Relief Committee which commends itself to all our readers. We feel the object is a worthy one and any one helping this cause to the small extent asked, will receive a memento which will give good satisfaction in the years to come.

This has been a hard year for philatelic publishers judging from the many changes which have taken place. Why it should be so, is a mystery to us.

Of course conditions in Europe are such as to account for the suspension of certain publications there but this surely should not to any great extent, affect us here in the United States.

Early in the spring announcement was made of the suspension of the Philatelic Journal of America; soon afterwards the Collectors Blue Book absorbed the New England Philatelist, The Stamp Journal of Florida, N. Y. and the Philadelphia Stamp News and appeared under the name of the Stamp Journal but the absorption seems to be so complete, that apparently it has not survived, and now comes the announcement of the Philatelic American, succeeding the Herald of Philately.

Verily, there are few left to represent this important field of philatelic endeavor and if they are worth anything at all, they surely deserve the support of collectors and dealers generally.

To be sure no one publication can combine in itself all the features to satisfy every one of its readers and we believe it is this which has caused the passing out of so many publications in the past.

We are looking forward to a year of renewed and increased circulation with its attendant growth and with the new articles and topics which we have in preparation and which will be presented in due course, we hope eventually to reach that state referred to above.

SHORT NOTES.

Mr. John A. Klemann, President of the Nassau Stamp Co. while in San Francisco attending the A. P. S. Convention, also found time to purchase the United States stamps and fourteen other complete countries of the celebrated Henry J. Crocker Collection.

This is the second important purchase of United States stamps by this firm during the past year, the first having been the gold medal Collection of Mr. Clarence E. Chapman in April.

The Crocker Collection like the Chapman Collection will be offered at private sale.

Doctor Carroll Chase has joined the Business Men's Military Camp at Plattsburg for the month of September.

Envelopes.

The Department has discontinued the manufacture of the following stamped envelopes and their sale will cease when the stocks remaining on hand have been sold.

- No. 1, 2c on white
- No. 2, 1c on amber, buff and blue
- No. 2, 2c on amber, buff and blue
- No. 14, 2c on buff and blue.

This also includes a supply of "open end" stamped envelopes which were manufactured under the contract ended June 30, 1911.

The "open end" envelope is intended for mail of the third class. One of the end flaps, instead of the top flap, remains unsealed, and contents can be readily examined. The opening is smaller than in envelopes with top flap unsealed, affording less chance of loss of contents in transit or of other pieces of mail matter getting caught in the opening.

The "open end" envelope can be furnished while the supply lasts, in the following varieties of 1-cent denomination:

- No. 5, white and amber
- No. 6, white and manila
- No. 13, white, buff and blue.

THE UNIVERSAL POSTAL UNION.

On Sept. 17th, the fortieth anniversary of the Universal Postal Union will be celebrated in Berne, Switzerland.

It may be of interest to note that since the Universal Postal Union was established in 1875, the following countries have been admitted and constitute the Union.

Countries Admitted Up to 1902.

- Argentine Republic including eastern parts of Patagonia and Terra del Fuego and Staten Island.
- Ascension, Island of (British Colony).
- Austria-Hungary including the Principality of Lichtenstein.
- Australia.
- Bahamas.

- Barbados.
 Bechuanaland Protectorate.
 Belgium.
 Bermudas.
 Bolivia.
 Bosnia-Herzegovina.
 Brazil.
 British Colonies on west coast of Africa, (Gold Coast, Lagos, Senegambia and Sierra Leone).
 British Colonies in West Indies, viz., Antigua, Dominica, Montserrat, Nevis, St. Christopher, The Virgin Isles, Grenada, St. Lucia, Tobago and the Turks Islands.
 British Guiana.
 British Honduras.
 British India: Hindostan, and British Burmah (Aracan, Pegu and Tenasserim) and the Indian postal establishments of Aden, Muscat, Persian Gulf, Gaudur, Mandalay.
 Bulgaria.
 Canada.
 Cayman Islands.
 Ceylon.
 Chile, including western parts of Patagonia and Terra del Fuego.
 Colombian Republic.
 Colony of the Cape of Good Hope, including Basutoland, Griqualand, Little Namaqualand, Pondoland, Tembuland, Transkei, Walfish Bay and Bechuanaland.
 Congo, Independent State of.
 Costa Rica.
 Cyprus.
 Danish Colonies of St. Thomas, St. Croix and St. John.
 Denmark, including Iceland and Faroe Islands.
 Dominican Republic.
 East Africa, British Protectorate.
 Ecuador.
 Egypt.
 Falkland Islands.
 Fiji Islands.
 France, including Algeria, The Principality of Monaco, the French P. O. establishments in Morocco, (Tangier, Casablanca, El-Ksar—El-Kbir [Alcazar], Fez, Larrache, Mazagan, Mogodor, Rabat, Saffi and Tetuan); at Shanghai, (China); and in Zanzibar, Cambodia, Annam and Tonkin.
 French Colonies.
 1. In Asia—French Establishments in India (Chandernagore, Karikal, Mahe, Pondicherry, Yanaon); and in Cochin China (Saigon, Mytho, Bien-Hoa, Poulo-Condor, Vinh-Long, Hatien, Tschandok).
 2. In Africa—Senegal and dependencies (Goré, St. Louis, Bakel, Dagana); Mayotte and Nossi Be, French Congo—Gaboon (including Grand Bassam and Assinie), Reunion (Bourbon), Madagascar, Obock on the east coast and the Comoro Islands (Grand Comoro, Anjouan, Mohele).
 3. In America—French Guiana, Guadeloupe and dependencies (Desirade or Deseada, Les Saintes, Marie Galante and the north portion of St. Martin), Martinique, St. Bartholomew, St. Pierre and Miquelon.
 4. In Oceanica, New Caledonia, Tahiti, Marquesas Islands, Isle of Pines, Loyalty Islands, the Archipelagoes of Gambier, Toubouai and Tuamotou, (Low Islands).
 Germany, including the Island of Heligoland and the German post offices at Apia (Samoan Islands) and at Shanghai (China).

German Protectorates:

Territory of Cameroons (Kameroun) (West Coast of Africa), German New Guinea (in Papua); German South West Africa, (Grand Namaqua, the Damaras Country and the southern portion of Ovambo, between Cape Colony and Angola); The Territory of Togo (Western Africa); German East Africa; the Marshall Islands, in the Pacific Ocean and Kiautschau (China).

Gibraltar and its postal Agencies in Morocco.

Great Britain and Ireland.

Greece, including the Ionian Isles.

Greenland.

Guatemala.

Haiti.

Honduras, including Bay Islands.

Hong Kong and the post offices maintained by Hong Kong at Kiung-Chow, Canton, Swatow, Amoy, Foo-chow, Ning-Po, Shanghai and Hankow (China).

Italy, including the Republic of San Marino, the Italian offices of Tunis, and Tripoli in Barbary; Massouah, Assab, Asmara and Keren (in the Italian Colony of Eritrea—Abyssinia).

Jamaica.

Japan, including Formosa and the Japanese post offices at Shanghai (China), and Fusam-po, Genzanshin and Jinsen (Corea).

Korea.

Labuan.

Liberia.

Luxemburg.

Malta and its dependencies, viz. Gozzo, Comino and Cominotto.

Mauritius and dependencies (The Amirante Islands, the Seychelles and Rodrigues).

Mexico.

Montenegro.

Natal, including Zululand.

Netherlands.

Netherlands Colonies:

1. In Asia—Borneo, Sumatra, Java (Batavia), Billiton, Celebes (Macassar), Madura, the Archipelagoes of Banca and Rhio (Riouw), Bali, Lombok, Sumbawa, Flores, the south west portion of Timor and the Moluccas.
2. In Oceanica—the north west portion of New Guinea (Papua).
3. In America—Netherlands Guiana (Surinam), Curacao, Aruba, Bonaire, part of St. Martin, St. Eustatius, and Saba.

New Foundland.

New Guinea, British Colony.

New South Wales, including Lord Howe Island and Norfolk Islands.

New Zealand, including Chatham Island.

Nicaragua.

North Borneo, British Colony.

Norway, including post office at Advent Bay on the west coast of Spitzbergen.

Orange Free State.

Paraguay.

Persia.

Peru.

Portugal, including the Island of Madeira and the Azores.

Portuguese Colonies.

1. In Asia—Goa, Damao, Diu, Macao, and part of Timor.

2. In Africa—Cape Verde, Bissao, Cacheo, Islands of St. Thomas and Prince, Ajuda, Mozambique, and the Province of Angola.
- Queensland.
- Roumania (Moldavia and Wallachia).
- Russia, including the Grand Duchy of Finland.
- Salvador.
- Samoa (Navigators) Islands, German Post Office at Apia.
- Sarawak, British Protectorate.
- Servia.
- Siam.
- South African Republic (The Transvaal).
- Spain, including Balearic Isles, the Canary Islands, the Spanish possessions on the north Coast of Africa (Ceuta, Penon de la Gomera, Alhucemas, Melilla and the Chafferine Islands), the Republic of Andorra and the postal establishments of Spain on the west coast of Morocco (Tangier, Tetuan, Larrache, Rabat, Mazagan, Casablanca, Saffi and Mogodor).
- Spanish Colonies:
1. In Africa—Islands of Fernando Po, Annobon and Corisco on the Gulf of Guinea.
- Strait Settlements (Singapore, Penang and Malacca).
- St. Helena, Island of (British Colony).
- St. Vincent, West Indies.
- South Australia.
- South Rhodesia.
- Sweden.
- Switzerland.
- Tasmania.
- Trinidad, West Indies.
- Tunis, Regency of.
- Turkey, (European and Asiatic).
- Uruguay.
- Venezuela.
- Victoria.
- Western Australia.
- Zanzibar, British Protectorate.

Countries Admitted Subsequent to 1902.

- Aden (including Perim), British Colony.
- Bechuanaland, British Protectorate, including Francistown, Gaberones, Kanye, Lake Ngami, Lobatsi, Macloutsie Mochudi, Mahalapye Siding, Mopolole, Palachwe, Ramoutoa, Shoshong and Tati River.
- British East Africa, Protectorate, including Uganda.
- British Colonies in the West Indies, viz.: the Grenadines.
- China.
- Cuba.
- Ethiopia.
- German post offices at Amoy, Canton and Weihsien Shantaikwan, Tschinkiang, Tongku, Tien Tsin, Chefoo, Peking, Itchang (China).
- Gilbert and Ellice Islands and Solomon and Shortland Islands.
- Malay States (Federated).
- New Hebrides.
- Southern Nigeria, British Protectorate, including Akassa, Asaba, Benin, Bonny, Brass, Burutu, Calabar, (new and old), Forcados, Onitsha, Opobo and Warree. (Withdrawal effective January 12, 1916).

Territory of the Caroline Islands, the Mariana Islands (except Guam), the Pelao Islands, in the Pacific Ocean, and German establishments in Morocco; Casablanca, Larrache, Marrakesch, Mazagan, Mogador, Rabat, Saffi and Tangier.

Japanese post offices at Chefoo, Foo-Chow, Hangchow, Shashi, Amoy, Hangkow, Peking, Foo Chow, Sungchin, Nanking and Newchang (China) and in Korea.

Panama, Republic of.

Russian post offices at Shanghai, Chefoo, Hankow, Kalgan, Kouldja, Ourga, Peking, Tien Tsin, Tougoutchak.

Somaliland, British Protectorate.

Postal establishments of Spain in Morocco (El-Ksar-el Kebir, Fez, Marrakesch and Mequinez).

The following are considered as belonging to the Universal Postal Union.

The German post offices established at Peking and Tsinanfu (China) as subordinate to the Postal Administration of Germany.

The post offices which the administration of the British Colony of Hong-Kong maintains at Lin Kung Island, Wei-hai-wei (China).

The post offices which the Administration of Japan maintains in China, Manchuria and the Island of Saghalien.

Postal Union rates and conditions apply to British India offices in various native States within the limits of Hindostan. To Kashmir, Ladak (Little Thibet), and Cabul (Afghanistan) in Italian mail, the same rates apply, but prepayment is compulsory, and only to the British Indian Frontier.

Correspondence for the Tunisian and Tripolitan ports of Sousse, Monastir, Mehdie, Sfax, Djerba and Tripoli, sent via France, is assimilated in all respects to correspondence for France. That for other portions of Tripoli, sent by the same route, is liable to the same rates of postage, but prepayment is obligatory and valid only to the port of debarkation, and registration is not possible. Correspondence for Goulette, near Tunis, and for Sousse in Tunis, sent via Italy, is assimilated in all respects to that for Tunis sent by the same route.

The Virgin Isles, belonging to Great Britain, comprise Tortola Anegada, Virgin Gorda, Jost Van Dyke, Guano Isle, Beef and Thatch Islands, Prickly Pear, Camanas, Coopers, Salt, Saint Peters, &c.

The Grenadines or Grenadilles, consist of Bequal, Caricou, Union and several smaller islands, belonging partly to Saint Vincent and partly to Grenada, W. I., colonies of Great Britain.

WASHINGTON NOTES.

By PHILIP H. WARD, JR.

Only the current 2c denomination has as yet been perforated 10 $\frac{3}{4}$ and no other value will be issued until the Post Office finally approves this new perforation. This approval may come in a week or may come in six months.

In the meantime all perforating machines are operating at 10 and all current stamps including the Panama-Pacific have been so issued except the regular 50c and the 3, 30 and 50c Due. A good supply of these values perf. 12 are on hand and whether they will ever be issued perf. 10 depends upon the date when the new perforation is adopted.

The Bureau has little or no information to offer in regard to the recent compound Perf. 10x12. It is possible that the stamp has been issued as it took about 10 days to change the perforating machines over. If the 2 cent was so

issued it is more than likely that other values were perforated during this time.

Through the efforts of the Bureau of Engraving and Printing and other interested parties, Great Britain has agreed to allow all dyes, chemicals, &c. not manufactured here to be shipped from Germany. This means our current 2 cent value will shortly go back to its former deep color.

It is not generally known that the first proofs from all stamp dies and plates are printed in green. This is in order to train the eye of the engraver more readily to recognize defects than would be possible if he examined each proof in its accepted color. These green proofs never leave the Bureau.

A trip to Washington by any Philatelist would not be complete without a visit to the Government Collection at the National Museum. Mr. Leavy is surely to be congratulated on his wonderful work which can only be completed through the efforts of outside collectors.

While the collection contains none of the so-called famous foreign rarities, it nevertheless is rich in United States and 20th Century with an unusually good showing of 19th Century.

NEW PLATE NUMBERS.

Through the courtesy of Mr. J. E. Ralph, Director of the Bureau of Engraving and Printing, we print herewith the full list of plate numbers to September 1, 1915:

| No. | Den. | Class | No. | Den. | Class |
|------|------|----------|------|------|------------------|
| 7494 | 2c | Ordinary | 7527 | 1c | Ordinary |
| 7495 | 2c | " | 7528 | 1c | " |
| 7496 | 2c | " Curved | 7529 | 1c | " |
| 7497 | 2c | " " | 7530 | 1c | " |
| 7498 | 11c | " | 7531 | 1c | " |
| 7499 | 11c | " | 7532 | 1c | " |
| 7500 | 1c | " | 7533 | 1c | " |
| 7501 | 2c | " | 7534 | 1c | " |
| 7502 | 2c | " Curved | 7535 | 1c | " |
| 7503 | 2c | " " | 7536 | 1c | " |
| 7504 | 11c | " | 7537 | 1c | " |
| 7505 | 11c | " | 7538 | 1c | " |
| 7506 | 1c | " Curved | 7539 | 1c | " |
| 7507 | 1c | " " | 7540 | 1c | " |
| 7508 | 1c | " " | 7541 | 1c | " |
| 7509 | 1c | " " | 7542 | 1c | " |
| 7510 | 2c | " " | 7543 | 1c | " |
| 7511 | 2c | " " | 7544 | 1c | " |
| 7512 | 2c | " " | 7545 | 1c | " |
| 7513 | 2c | " " | 7546 | 1c | " |
| 7514 | 1c | " | 7547 | 1c | " |
| 7515 | 1c | " | 7548 | 2c | Book |
| 7516 | 1c | " | 7549 | 1c | Ordinary |
| 7517 | 1c | " | 7550 | 2c | Book |
| 7518 | 1c | " | 7551 | 2c | " |
| 7519 | 1c | " | 7552 | 1c | Ordinary, Curved |
| 7520 | 1c | " | 7553 | 1c | " " |
| 7521 | 2c | " Curved | 7554 | 2c | Book |
| 7522 | 2c | " " | 7555 | 2c | " |
| 7523 | 2c | " " | 7556 | 2c | " |
| 7524 | 2c | " " | 7557 | 2c | " |
| 7525 | 1c | " | 7558 | 1c | Ordinary, Curved |
| 7526 | 1c | " | 7559 | 1c | " " |

CHRONICLE OF U. S. ENVELOPES.

BY J. M. BARTELS.

For explanation of watermarks see pages 187-8.

| B. No. | Denom. | Die Var. | Size | Paper | Wmk. | Knife |
|--------|--------|----------|--------|-------|------|-------|
| 2395b | 1c | C | 8 v.2 | Amber | 17 | 59 |
| 2456D | 2c | B | 7 | Buff | 17 | 51 |
| 2506C | 2c | D | 3 v.5 | White | 18 | 80 |
| 2612 | 2c | D | 3 v.5 | White | 17 | 92 |
| 2612C | 2c | D | 3 v.5 | Buff | 17 | 92 |
| 2669C | 2c | B | 3 | Blue | 18 | 92 |
| 2670A | 2c | B | 5 | Blue | 18 | 87 |
| 2679 | 2c | D | 11 v.5 | White | 18 | 88 |
| | 1c | C | 8 v.1 | White | 19 | 59 |
| | 1c | D | 13 | Amber | 19 | 89 |
| | 2c | A | 5 | White | 19 | 87 |
| | 2c | A | 5 | Blue | 19 | 87 |
| | 2c | A | 7 | Buff | 19 | 51 |
| | 2c | A | 13 | Blue | 19 | 89 |
| | 2c | A2 | 13 | White | 19 | 89 |
| | 2c | E | 5 | Amber | 19 | 87 |
| | 2c | E | 13 | Amber | 19 | 89 |
| | 2c | E | 13 | Blue | 19 | 89 |
| | 1c | A | 5 | White | 20 | 87 |
| | 1c | B | 8 | White | 20 | 59 |
| | 1c | C | 8 v.1 | White | 20 | 59 |
| | 1c | D | 8 | White | 20 | 59 |
| | 2c | A | 3 | White | 20 | 92 |
| | 2c | A | 4 | White | 20 | 84 |
| | 2c | A | 5 | Amber | 20 | 87 |
| | 2c | A | 7 | White | 20 | 51 |
| | 2c | A | 13 | White | 20 | 83 |
| | 2c | A | 13 | White | 20 | 89 |
| | 2c | B | 5 | Amber | 20 | 87 |
| | 2c | E | 5 | Blue | 20 | 87 |
| | 2c | E | 8 | White | 20 | 91 |

NEW ISSUE NOTES.

The following new issues have been shown to us during the past month.

Bulgaria, 10s. on 25s. blue and black (1911)**Dutch Indies.**

Red cross, surcharged on issue of 1912-14.

1c+5c olive green,

5c+5c rose,

10c+5c carmine rose.

Marshall Islands.

New surcharge, 1 on 2d on 10pf.

Portugal.

Postage due, permanent design.

 $\frac{1}{2}$ c brown, 1c orange, 2c claret, 3c green, 4c gray, 5c carmine, 10c blue.**Siam.**

2s. on 14a. blue (1912)

Spanish Morocco.

Surcharged Protectorado Espanol en Marruecos in three lines in red on all values except the 40c and 1p on which the surcharge is in green.

On Issue of 1877, 4/4c blue green.

On Issue 1909-10, 15c violet, 20c olive green, 25c blue, 30c blue green, 40c rose, 50c slate blue, 1p. lake.

Costa Rica.

It is reported that a decree dated July 20th authorizes the issue of postage due stamps on and after Aug. 1, 1915.

The denominations are 2, 4, 8, 10, 20c.

United States.

The official description of the new 11c stamps is as follows:

"The new stamp bears the head of Franklin in profile, from Houdon's bust, looking to the left and is printed in dark green ink. It is of the same shape (a rectangle on end) and size (about $\frac{7}{8}$ by 23-32 inch) as the other ordinary stamps, series of 1911. The border design is the same as that of the other denominations of the current issue above 7 cents.

This new stamp is issued primarily for use in prepaying postage on parcels, and postage and insurance fee on insured parcels, amounting to 11 cents."

BRITISH NORTH BORNEO.

The 2 Cents of 1883.

BY BERTRAM W. H. POOLE.

(Continued.)

No. 8.—There is a thin vertical line between the figure "2" and "CENTS" reaching to the frame line below, and the "T" of that word is badly shaped. There is a small dot of color in the right hand top corner of the left column, and another in the centre of the right column near the top.

No. 9.—The first "O" of "BORNEO" is badly battered on its left side, the lower arm of the "E" of "CENTS" is split at the end, there is a color dot below the space between the "TS" of "CENTS", and there is a large smudge of color between the two characters in the right column.

No. 10.—There is a tiny colored dot in the right column near the scroll at the top, another dot is shown under the "S" of "POSTAGE", and there is a smudge of color before the same word.

No. 11.—There is a minute colored dot before the figure "2", a small colored line is attached to the top of the "C" of "CENTS", and there is a blurr on the top of the "t" of "POSTAGE".

No. 12.—The lower line of the square in the top left hand corner is broken, and there is a small colored dot after "CENTS" near the frame line of the value tablet.

No. 13.—A colored dot is attached to the central portion of the figure "2", there is a dot under the curved portion of the "P" of "POSTAGE", two minute colored dots appear at the top of the right column, and there are three colored dots above the second native character in the same column.

No. 14.—There is a small colored line above the ornament in the upper left hand corner, and a minute colored dot appears above the first "COMMA" in the left column.

No. 15.—A colored dot is attached to the back of the "C" of "CENTS", there is a dot after the same word, and the line at the right of the value tablet is bent in the centre. A minute colored dot is shown in the space to the left of the square in the upper right hand corner.

No. 16.—There is a large splash of color above the second native character in the right column, there is a colored dot before the "O" of "POSTAGE", and the top line of the square in the lower left corner is broken.

No. 17.—There is a large colored dot to the right of the elower "COMMA" in the left column, a colored dot is attached to the front of the figure "2" and another appears under it, and the line above the "E" of "BORNEO" is broken.

No. 18.—There is a colored line across the uncolored border above "NORTH" there is a small colored dot in the left column almost opposite the top lines of shading in the shield, and there is a distinct stop after "CENTS".

No. 19.—There is a blotch of color on the line under the "R" of "NORTH", the last "O" of "BORNEO" is badly shaped, and the ball of the figure "2" is joined by a small colored line to the curve below.

No. 20.—There is a small colored line between the figure "2" and the word "CENTS", there is a blur of color on the white line above the "E" of "BORNEO" and the lion's tail is broken.

(To be continued.)

SOCIETY NOTES.

American Philatelic Society.

The 30th annual convention of the American Philatelic Society was held August 10, 11, 12, 1915 at San Francisco, California.

The business transacted was the regular routine, and there was not much of that as the affairs of the society were in very good shape due to the efficiency and careful supervision of affairs by the retiring Board of Officers.

The reports of the various officers showed a slight decrease in the membership and the Sales Department but a gain in the General Fund.

The Pacific Philatelic Society, which had the arrangements in hand, surely did everything possible to make the occasion a most enjoyable one.

Every visiting philatelist received a card making him an Associate Member of the Pacific Philatelic Society for the year 1915, a most gracious and complimentary act.

The convention badge, done in enamel, consisted of the emblem of the Pacific Philatelic Society with the proper inscription suitable for the A. P. S. It also has a metal loop at the top making it possible to use it as a medal or wear it as a fob.

Tuesday afternoon, Aug. 10th was given up to a most delightful trolley trip through Alameda County and the evening to a real old world stamp mart.

Wednesday afternoon, a boat ride round San Francisco Bay was the order of the day and in the evening at the Clift House the Convention Banquet. The menu made up of California products, follows:—

**DINNER FOR THE AMERICAN PHILATELIC SOCIETY, CLIFT HOTEL
August 11, 1915**

California Oyster Cocktail, Clift
Mock Turtle, Ancienne

| | |
|--|-----------------------|
| Olivedale Ripe Olives | Salted Jordan Almonds |
| Santa Cruz Bay Salmon, Hollandaise | |
| Persillade Potatoes | |
| Creamed Sweetbreads en Ramekins | |
| Punch Creme de Menthe | |
| Sonoma County Roast Turkey, Cranberry Sauce | |
| Browned Burbank Potatoes | Half Moon Bay Peas |
| Hearts of Los Angeles Lettuce, Cheese Dressing | |
| Orange Ice Cream | Assorted Fancy Cakes |
| Coffee | |

BEVERAGES.

| | |
|------------------------------------|--------------------------------|
| California Sauterne | California Claret |
| California Champagne | California Grape Juice |
| California Sparkling Mineral Water | California Still Mineral Water |
| California Beer | California Buttermilk |
| Spring Valley Water | Hawaiian Pineapple Juice |
| Coffee | Tea |
| | Chocolate |

Thursday morning the final business session was held and in the afternoon at 2:30 in the California Building, a medal commemorating the Convention was presented to the Society by Mr. Charles Vogelsang on behalf of

the Exposition Managers, to which Mr. W. C. Michaels responded for the Society.

The Convention was then adjourned sine die to meet in Boston, Mass., which was chosen as the Convention City for 1916.

Texas Philatelic Association.

An announcement has just been received from Mr. H. S. Parsons that Mr. Charles Roemer, of San Antonio, has been elected Sales Superintendent of the Texas Philatelic Association. Mr. Roemer recently retired from the management of the Sales Department of the Southern Philatelic Association after eight years of continuous service, and it was only after much persuasion that he was prevailed upon again to accept an official position of this character.

The T. P. A. is indeed fortunate in securing the services of a man with the experience and ability possessed by Mr. Roemer, and his personality, together with his excellent sales record with the S. P. A., will undoubtedly induce many of his friends and patrons to become members of the Texas society.

This organization, which is nearly twenty years old, is conducting an active campaign for the advancement of philately in southwestern United States and expects to gain many new members, as it is not necessary to be a resident of Texas in order to belong to the Association.



15 PROVISIONAL BELGIAN STAMPS

The Belgium Relief Committee has sent to this country 1,000 complete sets of cancelled Belgian Provisional Postage Stamps, issued from Havre—the temporary seat of government.

These sets are not for sale, but are to be used exclusively in connection with relief work for the Belgium Orphans, who are now being gathered up from the war zone.

Anyone contributing two dollars or over to this fund, will receive one of the sets of stamps as a memento. You may make your check payable to

GEORGE A. SAVOY, Chairman Belgian Relief Committee
c/o National Blank Book Co.,
HOLYOKE, MASS.

100 U. S. SELECTIONS

Every one of them covering a different field, are described in our new free

16 Page Pink List

which has just been issued. In addition it gives a detailed description of

300 Books by Countries

which contain the very pick of our large stock accumulated with much care and forethought. These selections generally contain unused and used stamps in shades, blocks and everything likely to attract the specialist or general collector. Thus every one finds something he requires and—at a satisfactory price.

Selections of Special Bargains

appear repeatedly in our new **PINK LIST**. Discounts naturally vary with quality. Some popular books (we have several of each number) are as follows:

No. 3. U. S. 1847-79, unused, General Issues. Attractive on account of discount from 40% to 70%.

No. 44. U. S. General Issues, Used. Stamps from 10c to \$2.00 each. Finest copies.

No. 46. U. S. Special Bargains. Not such very fine copies but 65 to 85% off catalog.

No. 50. Department Stamps. Big Discounts. Special Bargains.

Be sure to send for a copy of the above list. Then also remember that

We Are Always Buyers

of high grade material which we require to maintain the high standard of the above 400 selections.

J. M. BARTELS CO.
99 Nassau St., New York



Made in America

Interchangeable Leaves

BLANK ALBUMS - \$4.00 and up
STOCK BOOKS - \$2.00 and up

Used by the foremost Collectors and Dealers
Complete price list free on request



"No Plus Ultra" Watermark Revealer
Price 50c. Postage 10c. extra

All "No Plus Ultra" supplies manufactured exclusively by
SCOTT STAMP & COIN CO.
127 Madison Ave. New York City

WHITE BACKS.

| | |
|----------------------------|--------|
| British Guiana 96c | \$1.40 |
| Cayman Islands 10sh | 4.00 |
| Fiji 1sh | .50 |
| Gold Coast 5sh | 2.20 |
| Hong Kong 12 and 50c | .65 |
| Hong Kong \$5.00 | 4.10 |
| Trinidad 1sh | .42 |
| Strait's \$2.00 | 1.80 |

—also—

| | |
|--|-------|
| Togo on Gold Coast ½ to 5sh | 8.50 |
| Togo on Gold Coast 10sh | 6.25 |
| German Poland (5) | .30 |
| Russian Charity, large (4) | .25 |
| Dutch Indies 1915 50c | .30 |
| Trinidad "Red Cross" | .10 |
| Fiji 1 pound (George) | 6.15 |
| Jamaica 2sh CAC (8.00) | 5.50 |
| U. S. Navy Error 2c in black, pair imperf. | 22.50 |
| Agriculture 2c error "Sepcimen" .. | 32.50 |

Positively the finest assortment of 20th Century (unused) in the United States. Send for my various "B. B." lists.

19th CENTURY. I still have many items left from the Eugene A. Holton collection purchased by me last Spring.

Why not write me!

FRANK P. BROWN COMPANY,

325 Washington St. Boston, Mass.

I hold one of the

Finest Stocks

of rare and medium stamps in Europe.
My Specialties are

High Class Selections

of stamps of all countries and filling of want lists a/c to any catalogue. Owing to my systematic and continual fresh purchases, serious collectors have a good opportunity of acquiring "hard to get" stamps at moderate prices.

FOR SPECIALISTS,

interesting items in great variety.

W. HOUTZAMER,

368, Strand,

London, England.

(Formerly of The Hague, Holland.)

(Member of the Chicago Phil. Society, and of the American Phil. Society.)

TURKEY: Very fine lot of first issue on hand.

| | | |
|-------|-----------------------------|--------|
| *1865 | 10pa. bronze green | \$.30 |
| * | 25pia. orange red | 4.50 |
| *1869 | 5pia gray | .50 |
| * | 25pia. dull rose | 1.75 |
| *1876 | 5pia. gray blue | 8.00 |
| * | 25pia. dull rose | 8.00 |
| * | 25pia. claret & rose | .90 |
| *1884 | 5pa. lilac & pale lilac | 1.75 |
| 1886 | 25pia. bistre & pale bistre | 1.25 |
| *1887 | 10pa. on half 20 para | 1.75 |
| * | 20pa. on half 1pia. | 2.50 |
| * | 1pia. on half 2pia. | 1.50 |
| * | 2pia. on half 5pia. | 2.50 |

An exceedingly fine collection of varieties, imperf., inverted overprints, printed both sides, used & unused is being broken up.

Lots of uncatalogued varieties.

NORTH BORNEO.

| | | |
|-------|---------------------------|--------|
| *1883 | 4cts. rose | \$.40 |
| * | 8cts. on 2c. brown | 4.50 |
| * | 8cts. green | .75 |
| *1884 | 4cts. rose | 1.25 |
| * | 8cts. green | 1.25 |
| *1885 | 6 1ct. orange | 15.00 |
| *1886 | 3c. on 4c. rose | 1.65 |
| * | 5c. on 8c. green | 1.90 |
| * | 1c. rose (error in 4cts.) | 4.00 |
| * | 4c. rose imperf. | .60 |
| * | 8c. green imperf. | .60 |
| * | 10c. blue imperf. | .60 |
| * | 25c. slate blue | 5.00 |
| * | 50c. violet | 5.00 |
| * | \$1. red | 6.25 |
| * | \$2. sage green | 6.25 |
| *1890 | 2c. on 25c. slate blue | .90 |
| * | 8c. on 25c. slate blue | 1.90 |
| * | 8c. on 25c. blue | 6.25 |
| * | 6c. on 10c. blue | 1.50 |

Many Rarities and Varieties of Surcharge in stock.

C. G. DIETRICH
212 Broadway, New York, N. Y.

Member A. P. S., Dresden Philatelic Society, Berlin & Vienna Dealers Association, offers his superb stock of medium and rare stamps of all countries. Moderate Prices—Fine copies only.

SPECIALTIES
British—British Colonials—used and unused
19th and 20th Century.
Send Want Lists

A FEW NICE THINGS FOR THE CONNOISSEUR.

Gt. Britain.

| | | |
|---|--|-------|
| Scott's No. | | |
| 3—2p. blue—fine pairs. | | 3.75 |
| 3—same, strip of 3, late cancellation (bars) | | 15.00 |
| 3—same, fine strip of 3, Maltese Cross cancellation | | 9.00 |
| *307—I. R. Official, 5 Shill. rose | | 30.00 |
| 307—I. R. Official, 5 Shill. rose, fine, used | | 26.00 |
| 314—I. R. Official, £1 green, used | | 17.50 |
| Antigua. | | |
| * 20—1 Shill. violet | | 4.50 |
| * 20—same, block of four | | 20.00 |
| Bahamas. | | |
| * 2—1p. lake | | 8.50 |
| * 3—4p. rose | | 15.00 |
| 40—£1 green & black, on letter, rare | | 10.00 |
| Barbados. | | |
| * 43—5 Shill. dull rose | | 12.50 |

| | | |
|---|---|-------|
| 68—5 Shill. bistre, used or unused | | 3.25 |
| *79a—1£. gray and carmine, blue paper | | 1.75 |
| *84a—6p. violet and carmine, blue paper | | 7.50 |
| *85a—8p. orange and ultram. blue paper | | 6.00 |
| *86a—10p. blue green and carmine, blue paper | | 5.00 |
| *87a—2sh.6p. slate and orange, blue paper | | 5.00 |
| Br. Honduras. | | |
| * 51—50c on 1sh. gray | | 3.50 |
| * 51—same, block of four | | 15.00 |
| St. Vincent. | | |
| * 1a—1p. rose imperf. pair | | 25.00 |
| * 3—6p. dark green, \$2.75; horizontal pair | | 6.00 |
| * 7—4p. orange | | 12.50 |
| * 9—1sh. indigo. | | 13.50 |
| * 29—5sh. rose | | 55.00 |
| 30—½ on half of 6p. yellow green—unsevered pair | | 30.00 |
| Spain. | | |
| 3—5R red, horizontal strip | 3 | 18.50 |
| 5a—10R green, hor. pair | | 30.00 |
| 9—5R rose, vertical strip | 3 | 15.00 |
| 9—5R rose, vertical strip | 5 | 30.00 |
| 10—6R blue, vertical pair, | | |
| one cut close | | 15.00 |
| 15—5R light green, horiz. strip of 4 | | 10.00 |
| 15—5R light green, horiz. strip of 7 | | 20.00 |
| 16—6R greenish blue, horiz. pair | | 10.00 |
| 16—6R greenish blue, horiz. strip of 3 | | 16.00 |

THE PHILATELIC GAZETTE

PUBLISHED MONTHLY FOR STAMP COLLECTORS

VOL. V, No. 10.

NEW YORK, OCTOBER, 1915.

WHOLE No. 74.

COPYRIGHT, 1915, BY THE NASSAU STAMP CO.

The United States Government Collection of Postage Stamps.

BY JOSEPH B. LEAVY
Philatelist, U. S. National Museum.

(Continued.)

BRAZIL

- 1843, 30r black, 60r black, 90r black.
1844-46, 10r black (used), 30r black, 60r black, 90r black, 180r black (used damaged), 300r black (used damaged), 600r black (used damaged).
1850, 10r, 20r, 30r, 60r, 90r, 180r, 300r, 600r, black.
1854, 10r, 30r blue.
1861, 280r red, 430r yellow.
1866, 10r vermilion, 20r red lilac, 20r brown lilac, 50r blue, 80r slate violet, 100r blue green, 200r black, 500r orange.
1878-79, 10r vermilion, 20r violet, 300r green and orange.
1890-91, 20r gray green, 20r emerald green, 50r olive green, 100r lilac rose, type I, 100r lilac rose, re-engraved, 200r purple, 200r violet, 300r slate violet, 300r gray, 300r gray blue, 500r olive bistre, 700r fawn, 1000r yellow buff.
1891, 100r ultramarine and red.
1893, thick paper, 100r rose.
1894-97, 10r rose and blue, 20r orange and blue, 50r dark blue and blue, 200r orange and black, 200r orange yellow and black, 300r green and black, 300r blue green and black, 500r blue and black, 700r lilac and black, 1000r green and black, 1000r blue green and black, 2000r black and gray lilac, 2000r black and gray.
1898, provisional, surcharged on newspaper stamps, green surcharge, 500r on 300r carmine, 700r on 500r yellow, 1000r on 700r yellow, 2000r on 1000r yellow, 2000r on 1000r brown; violet surcharge, 100r on 50r brown yellow, 300r on 200r black; black surcharge, 200r on 100r violet, 700r on 500r green; red surcharge, 1000r on 700r ultramarine; black surcharge, 20r on 10r blue, 200r on 100r red lilac, 200r on 100r lilac; blue surcharge, 50r on 20r green; red surcharge, 100r on 50r green.
1899, 300r green and black (used).
1899, provisional, 50r on 20r gray green, 100r on 50r gray green, 300r on 200r purple, 500r on 300r slate violet, 500r on 300r gray lilac, 700r on 500r olive bistre, 1000r on 700r chocolate, 1000r on 700r fawn, 2000r on 1000r yellow buff.
1900, type I, 50r green, 100r rose, 200r dark blue (used).
Type II, 100r rose (used), 200r dark blue.
1905, 200r dark blue, 200r light blue, both used.
1900, 100r red, 200r green and yellow, 500r blue, 700r emerald green.

- 1906, 10r bluish slate, 20r aniline violet, 50r deep green, 100r aniline rose, 200r blue, 300r gray black, 400r olive green, 500r violet, 700r red brown, 1000r vermilion, 2000r yellow green, 5000r carmine.
- 1909, 200r deep blue.
- 1910, 600r olive green, 10000r brown.
- 1913, 1000r deep green.
- Newspaper stamps, 1889, 10r olive, 20r green, 50r brown yellow, 100r violet, 200r black, 300r carmine, 500r green, 700r ultramarine, 1000r brown.
- 1890-91, 100r violet.
- 1891-94, 10r blue, 10r ultramarine on buff, 20r green.
- Postage due, 1890, 10r orange, 20r ultramarine, 50r olive, 100r carmine, 200r magenta, 300r blue green, 500r slate, 700r purple, 1000r dark violet.
- 1895-96, 2000r brown.
- 1898, 100r brick red.
- 1906, 10r slate, 20r bright violet, 50r dark green, 100r carmine, 200r deep blue, 300r gray black, 400r olive, 500r dark violet, 700r red brown, 1000r red, 2000r green.
- 1910, 600r violet, 5000r chocolate.
- Official stamps, 1906, 10r, 20r, 50r, 100r, 200r, 300r, 400r, 500r, 700r, 1000r, 2000r, 5000r, 10000r orange and green.
- 1913, 10r gray and black, 20r olive and green, 50r black and gray, 100r vermilion and black, 200r blue and black, 500r yellow and black, 600r violet and black, 1000r brown and black, 2000r red brown and black, 5000r yellow brown and black, 10000r gray and black, 20000r blue and black, 50000r green and black, 100000r red and black, 500000r brown and black, 1000000r dark brown and black.

BULGARIA

- 1879, 5c black and yellow, 10c black and green, 25c black and violet, 50c black and blue, 1fr black and red.
- 1881, 3s red and silver, 5s black and orange, 10s black and green, 15s red and green, 25s black and violet, 30s blue and fawn.
- 1882, 3s orange, 5s green, 10s rose, 15s red violet, 25s blue, 30s violet and green, 30s lilac and green (used), 50s blue and pink, 50s blue and rose.
- 1884-85, 5s on 30s blue and fawn, 15s on 25s blue, both pen marked.
- 1885, 2s slate green.
- 1886, 1s gray violet, 2s slate green.
- 1889, 1s lilac, 1s rose lilac, 2s gray, 3s bistre brown, 5s yellow green, 10s rose, 15s orange, 25s pale blue, 25s gray blue, 30s dark brown, 50s dark green, 1 l orange red, all overprinted specimen.
- 1892, 15s on 30s brown.
- 1895, 01 on 2s slate green, 01 on 2s light slate green.
- 1896, 2 l rose and pale rose, 3 l black and buff.
- 1896, 1s blue green, 1s green, 5s dark blue, 5s blue, 15s purple, type II, 25s red, 25s orange red.
- 1901, 5s on 3s bistre brown, 10s on 50s green.
- 1901-06, 1s violet and gray black, 2s bronze green and indigo, 3s orange and black, 5s emerald green and brown, 10s rose and black, 15s claret and gray black, 25s blue and black, 30s bistre and gray black, 50s dark blue and brown, 1 l red orange and bronze green, type I, 2 l red and black, 3 l slate and red brown.
- 1903, 10s on 15s claret and black.
- 1907, 5s deep green, 10s red brown, 25s deep blue.
- 1909, provisional, 1s lilac, 5s yellow green, 5s on 30s brown, 10s on 15s orange, 10s on 50s dark green.
- 1909, provisional, 5s on 15s claret and black, 10s on 15s claret and black, 25s on 30s bistre brown and black.
- 1910, 1s on 3s orange and indigo, 5s on 15s claret and gray black.
- 1911, 1s myrtle green, 2s carmine and black, 3s lake and black, 5s green and black, 10s deep red and black, 15s brown bistre, 25s ultramarine and black, 30s blue and black, 50s ochre and black, 1 l chocolate, 2 l purple and black, 3 l blue violet and black.

- 1912, 5s olive green, 10s claret, 25s slate.
 1913, 1s myrtle green, 2s carmine and black, 3s lake and black, 5s green and black, 10s deep red and black, 15s brown bistre, 25s ultramarine and black.
 Postage due, 1884, 5s orange, 25s lake, 50s blue.
 1886, 5s orange (used), 50s blue.
 1887, 5s orange (specimen), 5s yellow, 25s lake, 25s carmine lake (specimen), 50s blue.
 1894, 5s orange, pelure paper.
 1895, imperforate, 30s on 50s light blue.
 Perforated, 30s on 50s blue, 30s on 50s dark blue.
 1896, 5s orange, 10s purple, 30s green, 30s slate green.
 1902-04, 5s dull rose, 5s pale rose, 10s yellow green, 10s olive green, 20s dull blue, 20s gray blue, 30s violet brown, 50s orange, 50s yellow orange.

(To be continued.)

THE CONFEDERATE STATES OF AMERICA.

A HISTORY OF THE GENERAL ISSUES.

BY BERTRAM W. H. POOLE.

(Continued.)

V.—THE HOYER AND LUDWIG STAMPS.

The Postmaster-General's report reproduced in the last chapter does not state at what date arrangements were made with the "lithographic establishment" or when the first supplies of stamps were delivered but merely adds "unexpected delay, however, occurred in the preparation of them". From a later report, dated February 28th., 1862, we learn that "the first postage stamps were delivered to the Department, under the contract by which it is now supplied, on the 15th. of October, 1861".

Messrs. Hoyer and Ludwig, of Richmond, Virginia, were the firm of lithographic printers referred to and though the services of their establishment were only made use of as "a temporary expedient", difficulties in the way of obtaining supplies of stamps elsewhere resulted in their contract extending over a period of nearly twelve months.

The first denomination issued to the public was undoubtedly the 5c; the 10c was ready shortly afterwards; while the 2c value, for drop letters, was not on sale until some months later.

At the time these stamps were issued the Southern States were almost entirely dependent on the North for nearly all classes of manufactured goods. It appears that not a single paper mill existed in any of the seceding States nor, though printing presses were no doubt quite plentiful, was there any establishment at which printing ink of a suitable character for the production of postage stamps was manufactured. Consequently supplies of paper and ink had to be obtained from the Northern States. Just prior to the commencement of active hostilities the Confederate Government contracted for a large supply of paper and envelopes and Major Evans, quoting from Mr. Corwin, tells how these materials were smuggled into the Confederacy viz:—

This stationery was sold by a certain well known citizen of New York to Mr. Joel White, a stationer of Montgomery, Ala. It was delivered at a certain point in Kentucky, whence Mr. White transported it within the Confederate lines. Ultimately the supply was taken to Richmond, when the seat of Government was removed thither upon May 20th, 1861, and there was enough of it to fill a large wareroom 100 feet by 60.

It was this paper that was employed in the manufacture of the lithographed stamps, and some of the engraved stamps as well. The ink employed came at first from the North, and was run through the blockade via Baltimore and Washington. When the United States authorities about these cities became more vigilant, it came in by sea, mostly by way of Charleston, S. C.



The 5 Cents, Green.

We have seen by the quotation given above that a supply of stamps was delivered to the Post Office Department on the 15th of October, 1861, and in view of the urgency with which they were required, it is only natural to imagine they would be placed on sale at once. Yet for a period of nearly twenty years the date of issue of the 5 cents (the first supply mentioned in the official report consisted of this denomination only), was stated to be October 18th, 1861. The basis for this statement was an alleged paragraph in the "Richmond Examiner" for October 19th viz.:—

The first of the new Confederate postal stamps were issued on the 18th of October, and were eagerly bought up. The new stamp is green, with a lithographic likeness of President Davis within a double oval border, surmounted with the inscription "Confederate States of America". Outside the circle and at the head of the stamp is the word "Postage" and at the lower edge its denomination "Five Cents".

Major Evans quotes the above paragraph from a statement made by Mr. Corwin and it remained unchallenged until 1910. In December of that year Mr. James L. Howe wrote in "Mekeel's Weekly Stamp News" that after a careful examination of the files of the Richmond newspapers for the fall of 1861 he was unable to find any reference to the new stamps in the "Examiner" of October 19th. On the other hand he found the following interesting paragraph in the October 16th issue of that newspaper viz.:—

POSTAGE STAMPS.—Sale of the new Confederate postage stamps will commence to-day at the Richmond Post-office. They are quite handsomely gotten up, are of a green color, and are ornamented with a likeness of President Davis. They will be of great convenience to the public.

This fixes the date of issue of the 5 cents as October 16th—the day after the stamps were delivered to the Post-office Department by the printers—and in further corroboration of this earlier date Mr. Howe found the following paragraph in the "Richmond Despatch" for October 17th:—

THE NEW POSTAGE STAMPS.—A very large number of the new Confederate postage stamps was disposed of yesterday (October 16th) at the Richmond postoffice. Their introduction supplies a want which has heretofore seriously taxed the public endurance. The stamps are of the size of those in use by the old U. S. Government, are colored green, and ornamented with a very excellent bust of President Davis. Messrs. Hoyer and Ludwig of this city have the credit of supplying the Government with these needed articles.

This, I think, is ample proof that the 5 cents stamps were actually issued on October 16th., but it would be interesting to know how the earlier quotation originated. The paragraph is proved to be non-existent so far as the "Examiner" is concerned. Yet Mr. Corwin must have had some substantial grounds for his quotation, and even had he been mistaken in the name of the newspaper it is curious Mr. Howe could find nothing in any of the Richmond papers having the least resemblance to the paragraph in question.

The earliest date among Mr. Klemann's stamps is a specimen on cover postmarked "Oct. 20 1861", and used from Richmond.

This 5 cents stamp shows a three-quarter face portrait of Jefferson Davis, the President of the Confederacy, with head to right. The portrait is enclosed within an upright oval frame and rests on a background of vertical and horizontal lines. Inside the oval, curved above the head, is the inscription "CONFEDERATE STATES OF AMERICA", in small uncolored capitals. Above the medallion is "POSTAGE" in large white shaded capitals, and at the base is the value "FIVE CENTS", in still larger capitals. Scroll and floral ornamentation completes the border and gives the stamp a rectangular shape. The design is really a handsome one, but the execution is poor so that in the majority of specimens the fine details of the background are lost in a blur of color. The lettering above the portrait is very inferior, many of the individual letters being so mis-shapen that it would be impossible to tell what they were meant to represent without having the rest of the inscription as a guide.

The 5c was printed in sheets of 200 stamps divided into two panes of 100 each (10 horizontal rows of 10) placed side by side. A space varying from $3\frac{1}{2}$ to 5mm. divides the two panes. The full sheet in Mr. Klemann's collection has a bottom margin of about 6mm. and this shows no sign of imprint. Major Evans, however, refers to a marginal imprint on this value as follows:—

A specimen, stated to have been cut from the first sheet printed, was obtained by Mr. Corwin from Colonel Offutt. It is a very fine clear impression, in a full green, deeper than that of the 2c, and with more yellow in it—a warmer shade if we may use such a term, but not by any means a yellow green. It is curious that this specimen is the only one we have been able to find showing the printers' inscription in the margin; the stamp is from the bottom row of the sheet, and has "HOYER & LUDWIG", in irregularly drawn, upright block capitals below it.

Mr. Melville, in his little brochure on these stamps, states that the full inscription is "LITH. OF HOYER & LUDWIG, RICHMOND, VA", but does not state whether he has actually seen a portion of the sheet showing this or not.

The stamps, as has been stated already, were printed by lithography and as is so frequently the case with stamps produced by this method the design was not transferred to the stone one at a time but a group of fifty transfers in five horizontal rows of ten was employed. Again, as is frequently the case, each of the stamps in this group has small peculiarities by means of which it can be identified from the others, making fifty types differing in very small particulars. Some of the differences on certain stamps are very minute making their identification a somewhat difficult matter though in pairs or blocks it is a comparatively easy task to "plate" this value. Before describing the peculiarities of the fifty types it is as well to make a few general observations. The dotted background in the portrait oval always extends on to the first S of STATES, and frequently encroaches on to other letters. There is always a thin colored line through the tops of the letters FI of FIVE. The outside stamps at the left and right sides of the sheet frequently have the outer frame lines omitted or very faint. The peculiarities distinguishing the fifty stamps in each group of transfers are:—

- No. 1.—There is a colored line or line of dots across the top of the T of CENTS, and colored smudges in the S of the same word.
- No. 2.—A small colored line crosses the white line immediately above the centre of the E of FIVE.
- No. 3.—There is a small uncolored flaw on the color above the top left corner of the N of CENTS.
- No. 4.—There is a small colored dot to the left of the small scroll ornament in the left lower corner.
- No. 5.—There are a number of colored dots on the P of POSTAGE.
- No. 6.—The letters ME of AMERICA are covered with colored dots.
- No. 7.—The right foot of the T of CENTS is almost obliterated by color.
- No. 8.—There are two colored dots below the arch of the scroll in the left lower corner.
- No. 9.—The outer line of the scroll ornamentation in the left lower corner is cut away.

No. 10.—Similar to # 9 but the break is more pronounced. There is a colored dot on the T of POSTAGE and the scroll ornament in the right lower spandrel is faint.

No. 11.—Practically all the frame line of the left lower spandrel ornamentation is removed.

No. 12.—Part of the curve of the left lower scroll is removed and a short colored line cuts through the top left corner of the E of POSTAGE.

No. 13.—A short colored line is attached to the left of the scroll in the left lower corner.

No. 14.—A colored line or smudge projects from the left hand frame about 1mm. above the corner scroll ornament.

No. 15.—There is a slight indentation in the outline of the oval background about 3mm. below the C of CONFEDERATE, and the shading after the T of POSTAGE usually impinges on the centre of the left leg of the A.

No. 16.—There is a colored dot on the inner white oval frame opposite the space between the letters CA of AMERICA.

No. 17.—There is a faint colored smudge 1mm. below the scroll in the left lower corner.

No. 18.—The vertical lines of shading above the T of POSTAGE are broken or removed.

No. 19.—The frame line of the left lower spandrel is weak and there is a heavy smudge of color on the left lower corner of the N of CENTS.

No. 20.—The frame line of the lower left spandrel is almost entirely absent and there are but few lines of shading on the collar. In the left lower group of transfers this stamp may be distinguished by a colored dot shown about 1½ mm. below the E of FIVE.

No. 21.—There is an uncolored flaw on the background 1mm. below the C of CONFEDERATE.

No. 22.—A prominent flaw is attached to the bottom of the C of CONFEDERATE.

No. 23.—There is a tiny colored flaw on the back of the head immediately in line with the ear.

No. 24.—The A of POSTAGE is covered with colored smudges.

No. 25.—There are two noticeable colored dots on the C of CENTS which are sometimes joined and form a roughly shaped V.

No. 26.—There is a tiny colored line under the bottom of the design, in line with the right lower corner of the I of FIVE.

No. 27.—There is a very plain colored dot below the design, close to the right hand side of the scroll in the left lower corner.

No. 28.—A tiny colored dot is shown in the top of the G of POSTAGE.

No. 29.—A prominent colored line is shown below the curve of the ornament in the left lower corner.

No. 30.—The top of the lower curve of the scroll ornament in the right upper spandrel is broken.

No. 31.—There is a tiny colored dot below and to the right of the right lower corner.

No. 32.—There is a colored smudge on the white line below the G of POSTAGE. This does not show on the stamp in the right lower group of transfers but in this case No. 32 may be distinguished by a tiny uncolored flaw under the T of POSTAGE.

No. 33.—There is a prominent uncolored flaw to the left of the G of POSTAGE.

No. 34.—There is a colored dot on the white line above the first T of STATES.

No. 35.—A colored line is drawn through the second E of CONFEDERATE.

No. 36.—There is a colored line on the white line of the oval above the ER of CONFEDERATE.

No. 37.—A colored line is shown through the white line of the oval above the right end of the first T of STATES.

No. 38.—There is a large flaw on the letters AT of STATES.

No. 39.—An uncolored flaw is shown on the colored line above the N of CENTS.

No. 40.—There is a tiny white dot above the F of FIVE which has extended into a large flaw on the left lower group of transfers.

No. 41.—There are a number of colored dots or smudges to the right of the lower righthand ornament.

No. 42.—A colored dot is shown below the centre of the ornamentation in the left lower corner.

No. 43.—An uncolored flaw is attached to the underside of the top left serif of the E of CENTS.

No. 44.—There is a tiny bulge on the right foot of the I of FIVE.

No. 45.—A distinct white flaw is shown on the back of the head.

No. 46.—The left foot of the A of CONFEDERATE is almost obliterated by color.

No. 47.—An uncolored flaw breaks the colored line above the F of FIVE.

No. 48.—There is a tiny colored line to the right of the scroll in the upper right spandrel.

No. 50.—A small period is shown between FIVE and CENTS.

(To be continued.)

BELGIUM: LINE-ENGRAVED STAMPS.

Notes on Classification.

By DEREK INGRAM,
Editor of "Stamp Collecting".

It has been well said that the thorough student of a particular branch of philately cannot go too deeply into his subject. Every little detail must have his attention, even though some of those little details may eventually lead to nothing and teach him nothing, for until he has studied them he cannot tell whether they are of importance or not. The greatest difficulty with which a collector who sets out to specialize any particular country or issue has to contend, seems to be the question of classification. Until the real specialist's catalogue makes its appearance, he must rely on his own discernment and degree of philatelic observation. It is, of course, hardly to be expected that there will be such a thing as a specialist's catalogue, even if only for the reason that many critics would accuse it of encouraging microscopical philately, by including varieties of all kinds and giving all of them equal prominence.

On the other hand, advanced philately would be robbed of many of the delights of research by the appearance of a price list of all varieties, for such a catalogue would undoubtedly be regarded as a list of the varieties which a specialist is bound to obtain. The "man in the street" would then want to be a specialist without the trouble of specializing; he would demand an album with spaces for every possible variety, so that he would have nothing to do but stick the stamps in it and then noise his "labours" abroad.

But it is not intended now to print a rambling dissertation on the subject to the relationship of the specialist to the catalogue. I shall confine only remarks in these pages to suggestions regarding classification of the varieties of the fascinating Belgian issues of 1849-65, which I venture to hope will be helpful to the specialist, although I would be the last to have the list regarded as an arbitrary catalogue of varieties. It should be remembered that stamps are, as a general rule, for government purposes and not merely for sale to collectors; they should, therefore, be first regarded from the point of view of the general public, and the post office clerk, thus considering primarily their general design and colour. Too many collectors pay far more attention to errors and adventitious varieties than to the subject represented on the printed label.

The question of classification of the postal issues of Belgium—particularly of the line-engraved stamps—is as entralling as that of any other country's issues. It involves careful research, which is one of the great charms of our hobby: it is this which makes us forget all our troubles and worries when we settle down to our stamps, and that renders stamp collecting a true recreation and diversion. If we want all the student work done for us, we may as well abandon philately as a science.

Before proceeding to the business of classification, let me mention the exhaustive series of articles on "The Belgian Postage Stamps of the Nineteenth Century" which Mr. Leavy contributed to the *Philatelic Record* during 1910-12 and those by Ch. de Bont on the "Postage Stamps of Belgium", which commenced to appear in *Gibbons' Stamp Weekly* in January, 1909. So far as the line-engraved stamps are concerned Mr. Leavy somewhat discredited the accuracy of the latter, as well as the articles on the same subject which appeared in the *American Journal of Philately* during 1896-7 and 1899-1900. As, however these monographs provide all essential information in regard to Government Decrees and manufacture of the stamps it will be sufficient for us now to classify all the known varieties without including explanation of their origin, etc., and to supplement these by suggestions connected with the colour scheme.

In my own contributions on the First Type of Belgian Stamps, now appearing in serial form in the *Philatelic Journal of Great Britain*, a historic and scientific analysis of the design is attempted, which data I hope to supplement later by further information I am endeavoring to procure through the medium of a descendant of the eminent engraver who was responsible for the beautiful stamps of 1849-65. This data, however, will not be in the nature of any discovery which would upset the present attempt at classification, and it is very unlikely that any fresh varieties of the early issues of Belgium have yet to come to light.

What we now have to consider is a classification based on

- (a) state of impression,
- (b) colour gradations,
- (c) double transfers of roller,
- (d) double impressions of plate,

according to the relative type of the normal stamp.

Comparative Rarity.

The comparative rarity of various stamps of the same series is of necessity a question which it is impossible to settle by the aid of a catalogue alone. Indeed, the catalogue is useless to a keen specialist of the Belgian line-engraved stamps. Scott, for instance, merely lists the 10c brown and 20c blue, without regard to the higher value of specific shades of these.

Where a wide range of shades is available and essential to a specialized collection, it behoves the philatelist to classify his stamps on scientific lines. The question of comparative rarity is indeed one on which the other sections of classification must needs have some bearing. Colour gradation, for instance, embraces a consideration of shades affected or otherwise by long exposure to the light and of the influence, in some cases, of substance from the printing plate (other than the pigment) upon the colour of the stamp. In addition, there is the all important question of paper, watermark, and perforation varieties.

State of Impression.

First Type

Colour trials for the Issue of July, 1849.

- 10c dark gray and red brown on white card,
- 10c red-brown on yellow paper and on card,
- 10c black on yellow paper,
- 20c black on yellow paper,
- 20c black on white polished card,
- 20c yellow on brown,
- 20c dark grey on white.

Die Proofs:—

On thick laid paper.

- 10c brown,
- 10c red-brown,
- 20c dark blue

(also all three on India paper and card)

On ordinary unwatermarked paper.

- 10c brown,
- 10c deep bistre, (Struck from die in 1866)
- 10c red-brown, (Struck from die in 1893)
- 20c blue, (Struck from die in 1866)
- 20c deep blue, (Struck from die in 1893)

On pelure paper.

- 10c violet-brown.
- 20c blue.

On thin highly surfaced wove paper.

- 10c violet-brown, (Struck from die in 1898)
- 20c blue, (Struck from die in 1898)

Some copies of the impressions of 1898 (usually termed "reprints") were cancelled officially by order of the Administration of Posts & Telegraphs, the cancellation reading "Bruxelles—Départ.—23 mai 1901."

Plate Proofs:—

- 10c black
- 20c black

Normal Impressions from the Plate:—

On hand made paper (Olin Brothers), watermarked double "L" interlaced within a single-lined rectangular frame, 22 by 18 mm. Varieties of watermark numerous, due to the monograms being twisted by hand and to impression, in many stamps from edges of the sheet, of part of the watermarked inscription "**Ministere des Travaux Publics, Bruxelles, Belgique Postes**" in double lined capital letters 6½ by 7mm each. A few stamps have no watermark. Deep, clear colours.

First Printing (May, 1849)—Medium Paper.

- 10c brown (1,600,000)
- 20c blue (1,500,000)

Second Printing (September, 1849) Thin Paper.

- 10c grey brown (3,000,000)
- 20c milky blue } 3,000,000
- 20c pale blue }

Third Printing, (May, 1850) Very Thin Paper.

- 10c brown } 800,000
- 10c red-brown }
- 20c dark blue } 500,000
- 20c pale blue }

The difference in intensity of the colours of the third printing, was due to frequent heavy charges of the plate with fresh pigment. These impressions were so heavy that they sometimes showed quite clearly on the reverse side.

Colour Gradations of the First Type.

In arriving at a consideration of the various changes of colour of the line-engraved stamps, quite distinct from the summary above, we must inevitably wish that colours might be standardised. At present, it is impossible to single out any specified stamp by merely naming the colour, even if we carefully describe the texture of the paper. What I mean to convey will perhaps be better understood when it is remembered that when a lady wants to match a particular dress she cannot write to the shop and secure the exact colour by a description of it. She must go to the establishment and compare the stuff with all shades which strike the eye as corresponding with the pattern. It would be far more satisfactory if the shopper—and the stamp collector—could specify the exact shade by referring to colour number so-and-so, remembering the analogy between colour and pitch. There is no

inherent reason why colours should not be standardised just as musical instruments are standardised to differences of pitch.

Even in the case of the first printing, although only the normal colours (deep, clear pigments) are tabulated above, at least three varieties of shade may be found in both values. These varieties, however, must be due entirely to atmospheric influence: yet they must have a distinctive note against them on the pages of the specialist's album. The only way is to classify them under the headings:—

- (a) normal shade
- (b) first degree of fading
- (c) second degree of fading.

and so on, grouping the varieties in three sections—first, second, and third printings.

Chemical changes have also to be considered. I have in mind several examples of changelings of the 20c value, owing to the influence of the weak solution of potash which was employed for cleaning the plates. The consequence of this has been the production of a faintly bluish tinge in the paper. Another curiosity of the 20c value is the presence of at least one badly oxidised copy. Here again the solution of potash seems to have given the deleterious effect by chemical action on the plates.

We must remember, too, that the wetting of the paper, causes apparent differences in the appearance of colours. If the paper is too wet, when the impression is taken, the colour is apt to impart a tone to the whole of the paper, in the same way as it is sometimes coloured by action of the potash solution (according to my theory). There is practically nothing of an abnormal nature in the great majority of existing 10c stamps, so far as their colour is concerned. The colour variations of the higher value, however, are so extensive that they might well be grouped somewhat as follows:—

- (a) Normal colour—rich blue
- (b) Degrees of shade as already suggested
- (c) Tone (where paper bluish)
- (d) Oxidised copies.

(To be continued.)

BRITISH NORTH BORNEO.

The 2 Cents of 1883.

BY BERTRAM W. H. POOLE.

(Continued.)

No. 21.—The “H” of “NORTH” is malformed, there are colored dots above the letters “OS” of “POSTAGE”, and the frame line under the figure “2” is badly bent.

No. 22.—The lower line of the square in the top left corner is broken, the left hand line of the square in the upper right corner is broken, there is a tiny colored dot at the top of the left column, and the ornament in the lower right corner is damaged.

No. 23.—The entire central portion of the first native character in the right column is absent.

No. 24.—The left hand part of the ornament in the upper left corner is damaged, and the top portion of the ornament in the lower right corner is also damaged.

No. 25.—There is an uncolored dot under the second “O” of “BORNEO”, the left arm of the “T” of “CENTS” is nearly all cut away, and there is a flaw on the shading under the left of the shield.

No. 26.—The left hand outer line of the shield is broken near the point, and there is a colored dot in the lower left leg of the ornament in the left lower corner.

No. 27.—There is an uncolored dot above the "N" or "NORTH", there is a small dot after and level with the top of the "E" of "POSTAGE", there is a tiny colored dot above the first native character in the right column, and the right hand top line of the lower character in the same column is damaged.

No. 28.—There is a colored dot between the two "COMMAS" in the left column, and the curl of the scroll under the last "O" of "BORNEO" is broken.

No. 29.—The line above the "E" of "BORNEO" is broken, the "C" of "CENTS" is badly formed, there is a dot above the "G" of "POSTAGE", there is an uncolored dot above the "R" of "NORTH", and a large splash of color joins the lion's head to his tail.

No. 30.—The "T" of "NORTH" is very thin and malformed, there are two colored dots at the top of the left hand column, and there is a thick line under the ornament in the top right hand corner.

No. 31.—There is a tiny colored line between the letters "NT" of "CENTS", and there is a v-shaped flaw on the inner line of the left column near the centre.

No. 32.—There is a small colored dot between the letters "TA" of "POSTAGE", and a small uncolored dot above the "B" of "BORENO".

No. 33.—There is a flaw on the ornamental scroll work on lower left side of shield, and a cigar-shaped mark on the shading to the left of the ship in the centre.

No. 34.—There is a splash of color on the white line under the "RT" of "NORTH", the "R" and "H" of the same word are malformed, and there is a large colored dot on the top end of the "S" of "CENTS".

No. 35.—The top portion of the ornament in the upper right hand corner is badly damaged, and the last "O" of "BORNEO" looks like a "Q".

No. 36.—A small uncolored dot is attached to the top of the last "O" of "BORNEO", the lower "COMMA" in the left column is broken, and there is a small break in the lion's tail.

No. 37.—The solid color above the "ORT" of "NORTH" is like a saw, there is a splash of color on the white line under the "RN" of "BORNEO", and there is a minute colored dot in the left lower corner of the value tablet.

No. 38.—The letters "ENT" of "CENTS" appear to be lined instead of solid, and the colored line under "NORTH" is doubled at its right hand end.

(To be continued.)

BOLIVAR.

The Stamps of 1879-1899.

By A. HATFIELD, JR., and BERTRAM W. H. POOLE.

(Continued.)

VII.—The 1883 Issue.

It will be remembered that during the period 1890-98 Seebeck's famous (or infamous, if you will) contract with Salvador and other countries was in vogue under which entirely new sets of postage stamps were supplied to the Governments agreeing to the scheme each year. The Bolivar issues of 1882-95 evidently represent Seebeck's initial effort along this line though as compared with his later work this manipulating of the postal strings with the intention of profiting from sales to stamp collectors was somewhat crudely done. As an artistic effort it certainly lacked finesse, for in the place of the handsome and widely differing designs which characterize the later and more generally known Seebeck issues, the same designs were retained for Bolivar with merely a change of date on them each year. It is hardly likely that such an almost trivial alteration can have excited a very extensive philatelic demand.

A comparison of the different series will show that all owe their origin to the same matrix dies and it is more than probable the changes of date were made on the transfers used in laying down the stones. A detailed comparison of the small peculiarities characterizing each value through its four changes of date is hardly necessary, but to prove our point we will mention



T.1



T.2



T.1



T.2



T.1



T.2



T.1



T.2



T.1



T.2



T.2

PLATE VIII

some of the minor details associated with the design of the 40c. Both left and bottom frame lines project at the left lower corner; the right lower corner is broken; the top line of the band containing EE. UU. DE COLOMBIA projects beyond the left frame and a small colored line is attached to the star immediately above the first U of the same inscription. These little peculiarities will be found on the 40c value of each of the four series. The designs of the stamps comprised in the 1883 issue are, therefore, precisely similar to those of the corresponding denominations of 1882, with the single exception of the alteration of date. The method of production was the same—lithography—and two transfers were used in laying down each stone, and, again, the same haphazard method in the arrangement of the two minor types of each value will be observed.

Evidently all the stones originally contained fifty impressions in five horizontal rows of ten each as in the case of the preceding issues and though sheets of all values were printed from these stones other sheets were printed containing only forty stamps—the upper four rows of the fifty impressions. The lower row may have been cleaned off or it may simply have been covered in some way to prevent the design printing. In either event the erasure was not complete for the upper portion of the discarded row, showing part of the frame and numerals, is printed on the lower margins of the sheets. The amount of the design shown varies. In the case of the 5c the erasure takes a slightly diagonal slope, and while about 6mm. of the top of the stamp at the extreme right is shown, only a small portion of the frame lines is shown at the extreme left.

The 5 centavo.

The two types of this value are quite easy to distinguish the chief points of distinction being:—

- Type 1.—There is a colored dot on the line above the date between the numerals "88" and another on the line immediately below the "1". The large "5" in the centre of the top frame has a colored line and dot in the ball giving it a distinctive appearance.
- Type 2.—The simplest test is the absence of the small colored dots shown on type 1 and the fact that the large "5" is normal in appearance, but in addition a small break will be found in the top of the D of DE, in the inscribed band below the portrait, this break generally extending into the band containing the stars.

There were two distinct stones for this denomination one of which is only known in sheets of fifty and the other in sheets of forty. The arrangement of the two types in the setting of fifty is as follows:—

| | | | | | | | | | |
|---|---|---|---|---|---|---|---|---|---|
| 1 | 1 | 2 | 2 | 2 | 1 | 1 | 1 | 2 | 2 |
| 2 | 1 | 2 | 1 | 1 | 1 | 1 | 2 | 1 | 1 |
| 2 | 1 | 1 | 2 | 1 | 1 | 2 | 2 | 1 | 1 |
| 1 | 1 | 1 | 1 | 2 | 2 | 2 | 2 | 2 | 2 |
| 2 | 2 | 2 | 1 | 2 | 1 | 2 | 1 | 2 | 2 |

It will be noted that though the arrangement is entirely without method there are nevertheless exactly 25 specimens of each type on the sheet.

The arrangement of the types on the sheet of forty is:—

| | | | | | | | | | |
|---|---|---|---|---|---|---|---|---|---|
| 1 | 1 | 1 | 1 | 2 | 2 | 1 | 1 | 2 | 2 |
| 2 | 1 | 1 | 1 | 1 | 2 | 2 | 1 | 1 | 2 |
| 2 | 2 | 2 | 2 | 1 | 2 | 1 | 1 | 2 | 1 |
| 2 | 2 | 1 | 2 | 1 | 1 | 2 | 1 | 2 | 1 |

This gives 21 specimens of type 1 and 19 of type 2. The lower row, which has been erased, we have been able to partly reconstruct from the test of the large "5" as follows:—

| | | | | | | | | | |
|---|---|---|---|---|---|---|---|---|---|
| 1 | 2 | 2 | 2 | 1 | 1 | 2 | 2 | 1 | * |
|---|---|---|---|---|---|---|---|---|---|

The only one in doubt is # 10 of which only a small portion of the upper frame line is visible.

The 10 centavos.

The two types of the 10c are also easily distinguished, the following being the identifying characteristics:—

Type 1.—May best be described as “normal” for it does not show the flaw which distinguishes type 2.

Type 2.—Has a prominent colored flaw below the “3” of “1883”.

The types were arranged on the sheet as follows:—

| | | | | | | | | | |
|---|---|---|---|---|---|---|---|---|---|
| 2 | 2 | 2 | 1 | 1 | 1 | 2 | 2 | 1 | 1 |
| 1 | 1 | 2 | 2 | 1 | 2 | 1 | 2 | 1 | 1 |
| 2 | 2 | 1 | 1 | 1 | 2 | 1 | 2 | 2 | 1 |
| 1 | 1 | 2 | 1 | 2 | 2 | 1 | 2 | 2 | 1 |
| 2 | 1 | 2 | 1 | 1 | 2 | 1 | 1 | 2 | 2 |

The setting was the same for both the forty and fifty stamp sheets in the former case, of course, the lower row being omitted. In the full sheets of fifty, therefore, 26 specimens of type 1 will be found and 24 of type 2, while in the sheets of forty there are 21 of type 1 and 19 of type 2.

The 20 centavos.

The distinguishing features of the two types of the 20c are:—

Type 1.—There is a large colored dot on the shading below the second O of CORREOS.

Type 2.—The upper right corner of the tablet containing CENTS has been cut away.

The disposition of the two types on the sheets is as follows:—

| | | | | | | | | | |
|---|---|---|---|---|---|---|---|---|---|
| 2 | 2 | 1 | 1 | 2 | 2 | 1 | 2 | 2 | 1 |
| 1 | 2 | 2 | 2 | 1 | 1 | 1 | 2 | 1 | 2 |
| 2 | 1 | 1 | 1 | 1 | 2 | 1 | 1 | 1 | 1 |
| 2 | 2 | 2 | 2 | 1 | 2 | 2 | 2 | 2 | 1 |
| 2 | 1 | 2 | 2 | 1 | 2 | 1 | 2 | 1 | 1 |

In this denomination also there seems to have been but one setting the sheets of forty being printed from the stone after the lower row had been partly erased. On the sheets of fifty, therefore, there are 24 stamps of type 1 and 26 of type 2 while on the sheets of forty there are 19 of type 1 and 21 of type 2.

The 40 centavos.

The two types of this value may be identified as follows:—

Type 1.—In the space under the right hand shield there is a curved colored line which joins the lower point of the shield with the dividing line above the top star.

Type 2.—There is a colored line below “83” of the date, another above the same “8”, and colored dots or smudges about and between the same numerals.

The sheet arrangement of the types is as shown in the following diagram:—

| | | | | | | | | | |
|---|---|---|---|---|---|---|---|---|---|
| 1 | 2 | 1 | 2 | 1 | 2 | 1 | 2 | 2 | 1 |
| 2 | 1 | 1 | 2 | 2 | 2 | 2 | 1 | 1 | 2 |
| 1 | 1 | 2 | 1 | 2 | 2 | 1 | 1 | 2 | 1 |
| 1 | 1 | 1 | 2 | 2 | 1 | 2 | 1 | 2 | 1 |

All the perforated stamps we have seen of this value consist of forty stamps as shown but in an imperforate block of 25 forming the left hand stamps as shown but in an imperforate block of 25 forming the left half of a sheet of fifty impressions we find the first five stamps of the lower row are:—

| | | | | | | | | | |
|---|---|---|---|---|---|---|---|---|---|
| 2 | 2 | 1 | 2 | 1 | * | * | * | * | * |
|---|---|---|---|---|---|---|---|---|---|

The 80 centavos.

The distinguishing features of the two types of this value are as follows:—

Type 1.—There is a small colored dot on the I of BOLIVAR near the centre at the right side.

Type 2.—There is no top to the E of CORREOS the letter merging into the uncolored line above.

The diagram given below shows the disposition of the types on the sheets:—

| | | | | | | | | | |
|---|---|---|---|---|---|---|---|---|---|
| 1 | 1 | 2 | 2 | 2 | 1 | 1 | 2 | 2 | 2 |
| 1 | 1 | 1 | 1 | 1 | 2 | 2 | 2 | 2 | 1 |
| 1 | 2 | 2 | 1 | 1 | 1 | 1 | 1 | 2 | 1 |
| 2 | 2 | 2 | 2 | 1 | 1 | 1 | 2 | 1 | 1 |
| 2 | 2 | 2 | 2 | 1 | 1 | 2 | 1 | 2 | 2 |

The same stone served for printing both the fifty and forty stamp sheets and, as will be noted, in the case of the larger sheets there are exactly 25 varieties of each type while in the smaller sheets there are 22 of type 1 and 18 of type 2.

The 1 peso.

The two types of the 1 peso are distinguished as follows:—

Type 1.—This may be described as normal for it lacks the characteristics of type 2.

Type 2.—The bottom of the letters CO of COLOMBIA are merged in the uncolored line below.

The two types are distributed on the sheets as follows:—

| | | | | | | | | | |
|---|---|---|---|---|---|---|---|---|---|
| 2 | 1 | 2 | 1 | 1 | 2 | 1 | 1 | 2 | 1 |
| 1 | 2 | 1 | 1 | 2 | 2 | 2 | 2 | 1 | 2 |
| 1 | 2 | 1 | 2 | 2 | 1 | 1 | 2 | 1 | 1 |
| 2 | 1 | 2 | 1 | 2 | 2 | 2 | 2 | 1 | 2 |
| 1 | 1 | 2 | 2 | 1 | 1 | 2 | 2 | 1 | 1 |

We have only seen sheets of fifty of this denomination and, as will be noted from the diagram above, there are exactly 25 of each type on the sheets.

Paper.

All the stamps of this set were printed on ordinary white wove paper.

Perforation.

Like the stamps of the 1882 series all six values are found perforated 12 all round and with a compound perforation of 16 by 12, the same perforating machines evidently continuing in use. As in the case of the other sets of this period nothing definite is known as to whether or not both varieties of perforation were in concurrent use. The "Philatelic Record" in chronicling these stamps in September 1883, makes no mention at all of the perforation, while about 1894 the compounds were generally listed as novelties. The 20c perf. 16 by 12, is known in horizontal pairs imperforate between.

Imperforate varieties.

All six values are known entirely imperforate and we have seen entire sheets of the fifty settings in this condition. The 5c is from the first of the two settings described above. These, as in the case of the similar varieties of the preceding issues, are best described as unfinished stamps.

(To be continued.)

THE PHILATELIC GAZETTE

Published the 15th day of each month

J. KLEMANN, Jr., Editor.

CLIFTON A. HOVES, Special Contributing Editor.

JOHN A. KLEMANN, Managing Editor.

Staff Writers.

CHARLES LATHROP PACK

J. MURRAY BARTELS

A. E. OWEN

B. W. H. POOLE

VICTOR M. BERTHOLD

DR. CARROLL CHASE

W. B. SPRAGUE

VAN DYK MACBRIDE

SUBSCRIPTION \$1.00 A YEAR, SINGLE NUMBERS 10c.

Advertising Rates

| | 1 mo. | 3 mos. | 6 mos. | 9 mos. | 12 mos. |
|--------------|--------|--------|--------|---------|---------|
| 1 inch | \$1.50 | \$4.00 | \$7.75 | \$11.50 | \$15.00 |
| ¼ p. | 5.00 | 13.50 | 26.25 | 38.00 | 50.00 |
| ½ p. | 8.50 | 23.00 | 44.50 | 65.00 | 85.00 |
| 1 page | 15.00 | 40.50 | 78.75 | 114.75 | 150.00 |

NASSAU STAMP CO., Publishers, 118 NASSAU ST., NEW YORK.

VOL. V, No. 10.

NEW YORK, OCTOBER, 1915.

WHOLE No. 74.

EDITORIAL.

The Stamp Market.

The liquidation and distribution of collections predicted at the beginning of the war has not materialized up to the present and from all reports it is not so likely to occur.

It would seem that now would be the time, if ever, for these holdings to be thrown on the market, but it is just this very thing which is not happening; instead, we have a steady and sustained demand for fine things from all of these countries even including Russia, with prices high enough to compete favorably in the American market; and this demand is not wholly for Europeans as was the case just prior to the war, but the call is increasing for United States issues.

The reason for this is not far to seek. It is a well known fact that collectors generally take up the issues of their own country first and follow with the next country which is most nearly allied in speech, manners, customs or business. The tremendous expenditures which these countries have made in the United States have drawn the attention of their people to our country and with the large number of collectors a general desire to collect our stamp issues. This desire, however, came just a trifle too late for them to obtain these stamps in their home markets because the American dealers in their annual pilgrimages to Europe had stripped the European markets of everything desirable and of value and now that the call for United States issues comes, both dealers and collectors must come to the United States for the stamps they desire.

As for the liquidation of stamp collections abroad to supply this demand, there is practically none. To be sure, collections are constantly being bought

and sold but so far as we are able to learn, there is no more of this than in normal times and the collections which are changing hands are relatively small and would have no appreciable effect upon the stamp market either abroad or here. Those collections which might have a tendency to shake the philatelic market are held by extremely wealthy owners like Count Ferrary in Paris, Baron Rothchild in Vienna and Mr. Henry J. Duveen in London with not the remotest possible chance of any of them being sold.

UNITED STATES LOCAL STAMPS.

A Concise History and Memoranda.

COMPILED BY HENRY C. NEEDHAM.

(Continued.)

AMERICAN EXPRESS COMPANY,
 AMERICAN MERCHANTS UNION EXPRESS COMPANY,
 MERCHANTS UNION EXPRESS COMPANY.
 Joint Stock Corporations.

We will consolidate in one article the companies above named, as they ultimately became the present American Express Company.

The American Express Company was organized under the Laws of New York, March 18th, 1850, and re-organized November 15th, 1859. It is not a corporation as such, but a voluntary or joint stock association. Again in 1868 it was re-organized and consolidated with the Merchants Union Express Company, another voluntary association organized under the New York Laws, and as now existing the Company commenced business December 1st, 1868. It controls, through stock ownership, The Westcott Express Company and The National Express Company. It operates its business over about 60,000 miles of railroads in the United States and Canada, many thousand miles in foreign countries, and about 140,000 miles of water routes. This Company today is one of the largest concerns of its kind. While it has no general capital stock, it has issued 180,000 shares of \$100 each, each certificate representing an interest in the business to the extent of the value shown on its face. The Fargo family have always been interested in the Company. Its principal office is at No. 65 Broadway, New York.

The Company had its original inception by consolidation of the old Local Posts and Express Routes of Pomeroy & Company; Livingston, Wells & Pomeroy; Livingston, Wells & Company; Livingston & Fargo; Wells & Company (Letter Express); Wells, Butterfield & Company; Butterfield, Wasson & Company; and Livingston, Fargo & Company; and, it is also claimed, that they took over the business of Bigelow & Company and Fisk & Rice, and many of the other small concerns existing in the East.

The Merchants Union Express Company was organized in New York in 1866 with a capital of twenty million dollars to compete with the then existing companies. Its management was hardly conservative, and, in 1868, it was consolidated with the American Express Company under the name of American Merchants Union Express Company with a capital of eighteen million dollars. The name was changed in 1873 to American Express Company.

James C. Fargo, President of the Company, died at New York City on February 8th, 1915. He was born at Watervale, N. Y., May 5th, 1829. At the early age of fifteen (1844) he entered the employ of Livingston, Wells & Pomeroy at Buffalo, N. Y. This Company, of which his brother, William G. Fargo, was a partner and resident manager, also owned the "Letter Express" running from Buffalo to Detroit, and operated under the name of Wells & Company. In 1847 he was the agent of the Company at Detroit,

AMERICAN EXPRESS COMPANY.



TYPE I

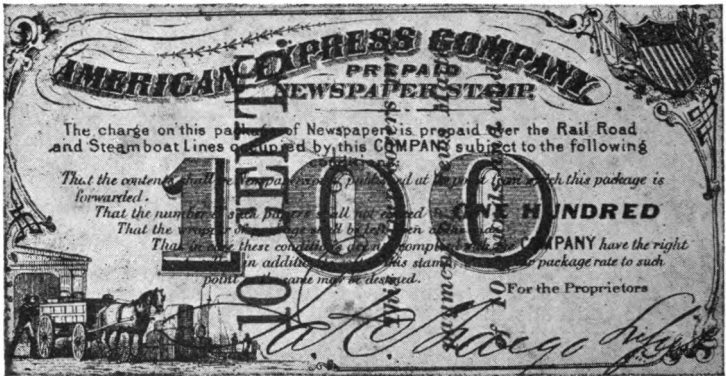

TYPE II



TYPE III

Michigan. In 1855 he was the agent of the American Express Company at Chicago. In 1867 he was the general Superintendent of the Company in New York City. In 1881, upon the death of his brother, he became the President of the Company and so continued until shortly before his death.

During the late sixties, and perhaps sometime thereafter, the Company issued stamps or labels to prepay expressage on newspapers and periodicals over its various routes. This statement applies to all companies above noted. The illustrations below will show the general purpose of the issue and the rates of postage; each stamp bore on its face, in large type, the number of newspapers or the equivalent thereof in other printed matter, which could be prepaid by the specimen. It is claimed by many that these stamps are labels.

Type I

No value expressed, black and claret on white, 25 papers. (5c).

Type II

10c surcharged in blue, black and red on white, 50 papers; 10 lbs. and under.

10c surcharged in blue, black and red on white, 100 papers; 10 lbs. and under.

10c surcharged in blue, black and red on white, 150 papers; 10 lbs. and under.

15c surcharged in blue, black and red on white, 100 papers; 10 to 15 lbs.

15c surcharged in blue, black and red on white, 150 papers; 10 to 15 lbs.

Type III

50c surcharged in blue, Book stamp, black and red on white, 200 papers or equivalent.

There may be many other stamps issued by this Company, the foregoing memoranda being taken from those in the Compiler's collection.

MERCHANTS UNION EXPRESS COMPANY.



TYPE I

Type I

No value, black on yellow, 5 newspapers;

No value, black on yellow, 10 newspapers;

No value, black on yellow, 25 newspapers;

No value, black on yellow, 100 newspapers;

No value, black on yellow, 200 newspapers.

The number of newspapers to be franked is indicated by large lettering impressed upon the surface of the stamp in black.

AMERICAN MERCHANTS UNION EXPRESS COMPANY.

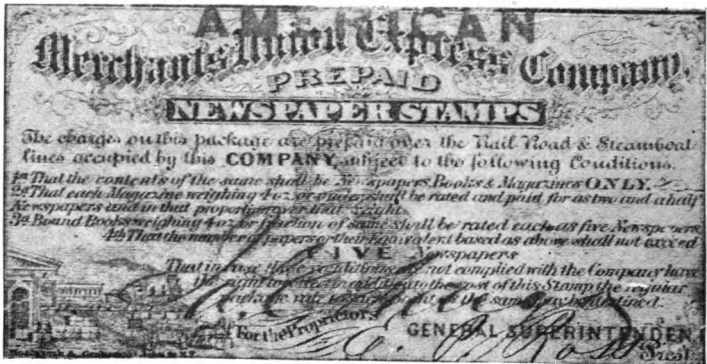

TYPE I



TYPE II



TYPE III

American Merchants Union Express Company.

PREPAID NEWSPAPER PARCEL STAMP.

FROM CHICAGO ONLY, to all points reached by this Company's lines, including Indiana, Michigan, Illinois, Wisconsin, Iowa, Missouri, Minnesota, Kansas, Nebraska, and Oklahoma.

25

Newspapers, Pamphlets, Magazines, and other printed matter, and any other matter than those enumerated, and is not to be used according to following conditions and WEIGHTS, Agents are instructed to use this stamp for parcels of the following weight: **ADD THIS STAMP.**

5 LBS. OR UNDER, - - - - -
 OVER 5 LBS. TO & INCLUDING 10 LBS., 15c.
 " 10 " " " 15 " 20c.
 And for every additional five pounds, or fractional part thereof, five cents.

O. M. Barrett

AGENT.

TYPE IV

American M. U. Express Co.

PREPAID PARCEL STAMP.

The charges on this package are prepaid over the Railroad and Steamship lines occupied by this Company, subject to the following conditions:

1st. This stamp is issued for the exclusive use of Dealers in the property covered by it, and is not valid for all other purposes.

2d. The contents of the package shall be Circulars, Hand Bills, and Posters, Book MSS. and Photo Engravings, Maps, Plans, Engravings, Signs, Blanks, Flexible Patterns, Separates and Remedy Cards, Photographs, Paper, Letter Envelopes, Postal Envelopes, Cards, Photostatic Reproductions of different types, Seals, Cuttings, Bulbs, Roots and Seeds, and is valued at not to exceed \$10.

3d. The weight of any package shall not exceed Five Pounds, or in size, one foot long, and six inches thick and wide.

4th. In case these conditions and Schedule Rates named below are not complied with, the Company have the right to collect regular package rate to such points as the same may be desired.

SCHEDULE OF RATES.

| Weight | Rate |
|-----------------------|---------|
| 12 oz. and under | 5 Cents |
| Over 12 oz. to 18 oz. | 9 " |
| " 18 " " 24 " | 10 " |
| " 24 " " 30 " | 15 " |
| " 30 " " 36 " | 20 " |
| " 36 " " 42 " | 25 " |

Jas. C. Fargo

Gen'l Agent

TYPE V

American M. U. Express Co.

PREPAID PARCEL STAMP.

The charges on this package are prepaid over the Railroad and Steamship lines occupied by this Company, subject to the following conditions:

1st. This stamp is issued for the exclusive use of Dealers in the property covered by it, and is not valid for all other purposes.

2d. The contents of the package shall be Circulars, Hand Bills, and Posters, Books, MSS. and Photo Engravings, Maps, Plans, Engravings, Signs, Blanks, Flexible Patterns, Separates and Remedy Cards, Photographs, Paper, Letter Envelopes, Postal Envelopes, Cards, Photostatic Reproductions of different types, Seals, Cuttings, Bulbs, Roots and Seeds, and is valued at not to exceed \$10.

3d. The weight of any package shall not exceed Five Pounds, or in size, one foot long, and six inches thick and wide.

4th. In case these conditions and Schedule Rates named below are not complied with, the Company have the right to collect regular package rate to such points as the same may be desired.

SCHEDULE OF RATES.

| Weight | Rate |
|-----------------------|---------|
| 12 oz. and under | 5 Cents |
| Over 12 oz. to 18 oz. | 9 " |
| " 18 " " 24 " | 10 " |
| " 24 " " 30 " | 15 " |
| " 30 " " 36 " | 20 " |
| " 36 " " 42 " | 25 " |

Jas. C. Fargo

Gen'l Agent

TYPE VI

American U. S. Express Co.

PREPAID
BOUND BOOK STAMP.

The charges on this package are prepaid over the Railroad and Steamboat lines occupied by this Company, subject to the following conditions:

1st. This Stamp is issued for the exclusive use of Dealers in the property covered by it, and is valid for all other purposes.

2d. The contents of the package shall be Bound Books only, and valued at not to exceed \$10.

3d. The weight of any package shall not exceed Five Pounds.

4th. In case these conditions and Schedule Rates named below are not complied with, the Company has the right to collect regular package rate to such points as the same may be destined.

SCHEDULE OF RATES.

| | |
|-----------------------|-----------|
| 12 oz. and under, | 10 Cents. |
| Over 12 oz. to 1 lb., | 15 " |
| " 1 lb. " 2 lb., | 25 " |
| " 2 lb. " 3 lb., | 35 " |
| " 3 lb. " 4 lb., | 45 " |

Jas. C. Fargo,
Gen'l Supt.

TYPE VII

American U. S. Express Co.

PREPAID
NEWS-MATTER STAMP.

The charges on this package are prepaid over the Railroad and Steamboat lines occupied by this Company, subject to the following conditions:

1st. This Stamp is issued for the exclusive use of Dealers in the property covered by it, and is valid for all other purposes.

2d. The contents of the package shall be Newspapers, Magazines, and Unbound Books, only, and valued not to exceed \$10, and the weight of any package shall not exceed Fifteen Pounds.

3d. In case these conditions and Schedule Rates named below are not complied with, the Company has the right to collect regular package rate to such points as the same may be destined.

SCHEDULE OF RATES.

| | |
|----------------------|----------|
| 1 lb. and under, | 5 Cents. |
| Over 1 lb. to 3 lb., | 10 " |
| " 3 lb. " 6 " | 15 " |
| " 6 " " 10 " | 25 " |
| " 10 " " 15 " | 40 " |

J. C. Fargo,
Gen'l Supt.

TYPE VIII

American U. S. Express Co.

PREPAID
NEWS-MATTER STAMP.

The charges on this package are prepaid over the Railroad and Steamboat lines occupied by this Company, subject to the following conditions:

1st. This Stamp is issued for the exclusive use of Dealers in the property covered by it, and is valid for all other purposes.

2d. The contents of the package shall be Newspapers, Magazines, and Unbound Books, only, and valued not to exceed \$10, and the weight of any package shall not exceed Fifteen Pounds.

3d. In case these conditions and Schedule Rates named below are not complied with, the Company has the right to collect regular package rate to such points as the same may be destined.

SCHEDULE OF RATES.

| | |
|----------------------|----------|
| 1 lb. and under, | 5 Cents. |
| Over 1 lb. to 3 lb., | 10 " |
| " 3 lb. " 6 " | 15 " |
| " 6 lb. " 10 " | 25 " |
| " 10 " " 15 " | 40 " |

Jas. C. Fargo,
Gen'l Supt.

TYPE IX

Type I

No value, black on yellow, 5 papers, surcharged with the word "American" in black type over the words "Merchants Union Express Company".

Types II and III

No value, black on white, prepaid news parcel stamp, 5 papers;

No value, black on white, prepaid news parcel stamp, 10 papers;

No value, black on white, prepaid news parcel stamp, 15 papers.

There are probably other values of these types.

Type IV

No value, black and carmine on white, prepaid newspaper parcel stamp; 25 papers.

Type V

No value, black and salmon on white, prepaid parcel stamp; 5 papers.

Type VI

No value, black and salmon on white, prepaid parcel stamp, 10 papers.

Type VII

No value, black and pink on white, bound book stamp; 15 papers.

Type VIII

Prepaid news matter stamp, green and blue on white, 5 papers.

Prepaid news matter stamp, green and blue on white, 10 papers.

Prepaid news matter stamp, green and blue on white, 15 papers.

Type IX

Prepaid news matter stamp, black and blue on white, 10 papers.

It is understood that the foregoing varieties and types are not necessarily complete, and that additional varieties would have little enhanced value over those above noted.

(To be continued.)

NEW ISSUE NOTES.

We are indebted to Mr. J. B. Leavy for copies of the following circulars sent out by the Director of the Universal Postal Union, announcing the July and August distributions.

August 6, 1915

1st. **China:** Postage stamps of $\frac{1}{2}$, 1, 2, 3, 4, 5, 6, 7, 8, 10, 15, 16, 20, 30, 50 cents, and 1 dollar, for the use of the Chinese offices in the province of Sinkiang (Chinese Turkestan). (These stamps bear an overprint in the Chinese language, stating that they are valid only for the prepayment of correspondence originating in that province exclusively. The issue of these stamps became necessary by the special monetary conditions of Sinkiang in its relations with the other provinces of China).

2nd. **Denmark:** Provisional postage stamp of 80 on 12 ore, provisional official stamp of 80 on 8 ore, and a postal card of 10 ore.

3rd. French Colonies:

(a) **French Somali Coast:** Postage stamps of 1, 2, 4, 5, 10, 20, 25, 30, 35, 45, 50, 75 centimes, 1, 2, and 5 francs, and postage due stamps of 5, 10, 15, 20, 30, 50, 60 centimes, and 1 franc;

(b) **French Oceania Settlements:** Postage stamp of 10 centimes of the "passe partout" type, bearing the overprint E F O with 1915 below;

(By order dated the 26th of May, 1914, the Governor of the French Settlements of Oceania withdrew from circulation, commencing with the 1st of December 1914, all the postage stamps previous to those of the last issue, representing native types and a landscape. Exception has been made of the postage stamps of 15 centimes as well as the postal cards and stamped envelopes of previous issues, which will continue to be valid.

Correspondence of every nature prepaid by means of postage stamps withdrawn from circulation will be considered as unprepaid and treated as such);

(c) **St. Pierre and Miquelon:** Red cross postage stamp of 10+5 centimes;

4th. Great Britain:

- (a) **United Kingdom:** Postage due stamp of 1 shilling;
- (b) **East Africa and Uganda:** Postage stamp of 25 cents;
- (c) **Ceylon:** Postage stamp of 2 rupees;
- (d) **Fiji Islands:** Postage stamp of 1 shilling;
- (e) **Jamaica:** Postage stamps of 3 pence and 1 shilling;
- (f) **Nigeria:** Postage stamps of 4 pence, 1 and 5 shillings;

5th. Dutch Indies: Red cross postage stamps of 1 + 5, 5 + 5, and 10 + 5 cents, valid only in the domestic service, and a red cross postal card of 5 + 5 cents (with overprint outside of the stamp), intended for both domestic and international service. (These values were put into circulation on the 10th of June last; the proceeds of the surplus of 5 cents will be contributed to the fund of the Indo-Dutch Central Red Cross Committee and to other international relief funds).

6th. Persia: Postage stamp of 24 shahis for parcel post packages (Persian crown series).

7th. Portuguese Colonies:

(a) **Macao:** Postage stamp of 10 reis with the portrait of Dom Louis, bearing in red overprint the word "Republica" and in black overprint "6 avos";

Of 5, 10, 15, 25, 80, 100, and 200 reis with the portrait of Dom Carlos (1st issue) bearing in red overprint the word "Republica" and in black overprint "6 avos";

Of 2 ½ reis of the 1st issue of Dom Carlos bearing in red overprint the word "Republica" and in black overprint "18 avos";

Of 20, 50, 75, 150, and 300 reis with the portrait of Dom Carlos (1st issue) bearing in red overprint the word "Republica" and in black overprint "18 avos";

Of 8 and 10 avos with the portrait of Dom Carlos (2nd issue) bearing in red overprint the word "Republica" and in black overprint the mention "Provisorio";

Of 8 avos with the emblem of the Republic;

(b) **Timor:** Postage stamps of 5, 25, and 50 reis with the portrait of Dom Carlos (1st issue) bearing in red overprint the word "Republica" and in black overprint "5 avos";

Of 2 ½ reis of the 1st issue of Dom Carlos bearing in red overprint the word "Republica" and in black overprint "6 avos";

Of 20 reis with the portrait of Dom Carlos (1st issue) bearing in red overprint the word "Republica" and in black overprint "6 avos";

Of 15 and 75 reis with the portrait of Dom Carlos (1st issue) bearing in red overprint the word "Republica" and in black overprint "9 avos";

Of 10, 100, and 300 reis with the portrait of Dom Carlos (1st issue) bearing in red overprint the word "Republica" and in black overprint "15 avos";

Of 80 and 200 reis with the portrait of Dom Carlos (1st issue) bearing in red overprint the word "Republica" and in black overprint "22 avos";

Of 3 avos with the portrait of Dom Carlos (2nd issue) bearing in red overprint the word "Republica" and in black overprint the mention "Provisorio";

Of 12 avos with the portrait of Dom Carlos (2nd issue) bearing in red overprint the word "Republica" and in black overprint "10 avos"; the 12 avos being barred out by a line;

8th. Turkey: Postage stamps of 100 and 200 piastres, overprinted respectively 10 and 25 piastres; the second of these stamps is also overprinted "El Ghazi" in Turkish;

9th. Union of South Africa: Postage stamps of ½, 1, 2, 3, 5, 6 pence and 1 shilling; postal cards of ½ penny and ½ ½ penny; letter sheet of 1 penny; stamped envelopes of 1 penny (2 sizes); registered envelope of 4 pence (2 sizes) and stamped wrappers of ½ and 1 penny.

NOTES.

The East Africa and Uganda, Ceylon, Fiji Islands, Jamaica, and Nigeria are all on paper colored through.

The Union of South Africa postage due are similar in type to the due stamps of Transvaal, a colored rectangular frame with the value in black

upon a central medallion of white, except the 1 shilling, which has the value in red. The top frame label bears the inscription Union of South Africa, the bottom label Unie van Zuid Africa, the left label Postage Due and the right label Te Betalen. The colors are:

| | |
|-------------------------|-----------------------------|
| ½ penny green & black. | 3 pence blue & black. |
| 1 penny red & black. | 5 pence gray brown & black. |
| 2 pence violet & black. | 6 pence gray & black. |
| 1 shilling black & red. | |

Denmark. 80 ore surcharged in black upon the 12 ore 1896 claret and slate, perforated 12½. 80 ore surcharged in black upon the 8 ore 1899 official rose carmine, perforated 12½. The word Post at top of stamp is obliterated by a black overprint DANMARK, the 8 ore in bottom label is obliterated by black overprint POSTFRIM, the Danish inscriptions at each side are obliterated by 11 black xxxxxxxxxxxx. The Postal Union has listed the stamp wrongly, it is a provisional postage stamp and not a provisional official stamp. Of the three copies received at the Museum one is an error having POSTERIM for POSTFRIM.

The French Somali Coast are a new bi-colored design, the 1, 2, 4 and 5 cent having a background of a mountain field with goats feeding; a medallion at right centre shows a native beating a tom-tom in the street and the numeral of value on a white inlet; the upper left corner bears the letter R and the upper right the letter F; at the bottom in fancy type is the inscription COTE FRANCAISE des SOMALIS all in the color of the medallion; at the top the word POSTES appears upon the background in white. The 10, 20, 25, 30, 35, 45, 50, and 75 centimes have a background of a sea scene showing coral atolls and beneath the surface two fishes swimming; at the right centre a medallion showing a half length portrait of a native woman; beneath the medallion a shell upon which the numeral of value appears, the same corner letters and inscriptions are shown, but in these values they are in the color of the frame. All the foregoing stamps are large rectangles. The 1, 2, and 5 francs are large oblong stamps having a fancy frame bearing at top the inscription POSTES in white on each side of a lined medallion upon which the letters R-F appear in color; the bottom bears a fancy medallion label in the centre upon which the value is shown in color upon white; to the left is COTE FRANCAISE and to the right des SOMALIS, all in white letters; the central medallion shows a rail-road trestle across a gorge with a train crossing the trestle. In giving the colors that of the frame is given first.

| | |
|-------------------------------|------------------------------|
| 1c violet & red brown. | 25c bright blue & dark blue. |
| 2c yellow buff & indigo. | 30c black & blue green. |
| 4c brown & red. | 35c yellow green & carmine. |
| 5c yellow green & green. | 45c red brown & dark blue. |
| 10c carmine & dark brown red. | 50c carmine rose & black. |
| 20c orange & black brown. | 75c purple & dark red brown. |
| 1fr. gray brown & red. | |
| 2fr. indigo & black. | |
| 5fr. red & black. | |

The French Somali Coast postage due are of a new design, small rectangular stamps with narrow fancy frame showing at the left in white letters the inscription COTE FRANCAISE, at the right DES SOMALIS, and at top R. F.; upon a central vertically lined background is shown, fancifully grouped, a bunch of spears, in the centre of which is a round shield upon which the numeral of value is shown in color upon a white ground; over the spears to the upper right of the shield is CHIFFRE—TAXE, to the left of the shield and slightly below it is A, and directly below the shield PERCEVOIR, all in white letters.

| | |
|-----------------|----------------|
| 5c bright blue. | 30c orange. |
| 10c dark red. | 50c dark red. |
| 15c dark brown. | 60c green. |
| 20c violet. | 1fr dark blue. |

The 10 centimes and 50 centimes are in exactly the same color.

September 8, 1915

1st, **Belgian Colonies: Belgian Congo:** Postage stamps of 5, 10, 15, 25, 40 and 50 centimes, 1 franc and 5 francs; postal cards of 5, 10, 5+5 and 10+10 centimes.

2nd, **Denmark:** Postage stamp of 80 ore.

3rd, **France:** Postage stamps of 1 centime, 2, 3, 5, 10, 20, 25, 35, 50 centimes and 1 franc, which have gone into service in the French office of Morocco comprised in the zone of the French Protectorate.

4th, **Great Britain:**

(a) **Cyprus:** Postal card of 1 piastre;

(b) **Nyasaland (Protectorate):** Postage stamp of 2 pence.

5th, **Venezuela:** Postage stamps of 5, 10, 15, 25, 40, 50, 75 centimos and 1 bolivar.

The office of Great Britain has expressed the desire to receive hereinafter but 68 specimens, in lieu of 70, of the postage stamps, etc., which are distributed.

I have in consequence the honor of asking you to send me in the future 369 specimens in lieu of 371.

NOTES

Belgian Congo. Except for a slight change in the 5, 10, and 25 cents the stamps are the same in design as the 1910 issue. The three stamps mentioned have had the fancy ornament above CONGO BELGE removed and in its place appear the words CINQ, DIX, and VINGT-CINQ, respectively. The colors are as follows:

| | |
|---------------------------------|-------------------------------------|
| 5 centimes green & black. | 40 centimes dark brown red & black. |
| 10 centimes carmine & black. | 50 centimes lake & black. |
| 15 centimes blue green & black. | 1 franc olive & black. |
| 25 centimes blue & black. | 5 francs ochre & black. |

Without doubt this is the worst case of "stamps for revenue only" that has yet been foisted upon long suffering philatelists.

Denmark. 80 ore in current type in blue green. This stamp following so closely upon the provisional 80 ore should make the latter good.

French Morocco. Current stamps of French Morocco overprinted in small black capitals PROTECTORAT FRANCAIS, in two lines on the values 1 to 35 centimes and in one line on the 50 centimes and 1 franc.

Venezuela. New design with portrait of Bolivar.

| | |
|--------------------------|--------------------------|
| 5 centimos dark green. | 40 centimos gray green. |
| 10 centimos vermilion. | 50 centimos dark violet. |
| 15 centimos gray olive. | 75 centimos blue green. |
| 25 centimos bright blue. | 1 bolivar gray black. |

CHRONICLE OF U. S. ENVELOPES.

BY J. M. BARTELS.

| B.No. | Denom. | Die Var. | Size | Paper | Wmk. | Kn. |
|-------|--------|----------|------|-------|------|-----|
| — | 1c | A | 13 | White | 19 | 89 |
| — | 1c | D | 5 | White | 19 | 87 |
| — | 2c | A | 8 | Amber | 19 | 59 |
| — | 2c | A | 8 | Buff | 19 | 89 |
| — | 2c | E | 5 | Buff | 19 | 87 |
| — | 1c | A | 13 | White | 20 | 89 |
| — | 1c | C v.2 | 5 | White | 20 | 87 |
| — | 1c | C v.2 | 8 | White | 20 | 59 |
| — | 1c | D | 5 | White | 20 | 87 |
| — | 1c | D | 13 | Buff | 20 | 89 |
| — | 2c | A | 8 | White | 20 | 91 |
| — | 2c | A | 14 | White | 20 | 93 |

We have seen a 2c envelope, size 14, on white having the same shape that is now being used for sizes 3, 5, 8 and 13. The new knife will be known as 93. As this change of knife has not been mentioned by the P. O. Department, it comes as a surprise to collectors.

The paper used for the envelopes of the 1915 series is wove. So far, we have not noticed a single exception.

UNITED STATES CONFEDERATES Locals and Carriers

What Have You to Offer?

JOHN A. KLEMANN
118 Nassau St., NEW YORK

103rd SALE.

20th Century Collection.
OCTOBER 25, 1915.

104th SALE.

U. S. & Foreign Stamps.
NOVEMBER 17, 18, 1915.

IN PREPARATION.

Collection of the late Charles Gregory

Catalogues mailed on request.

J. C. Morgenthau & Co.
87 Nassau St., New York

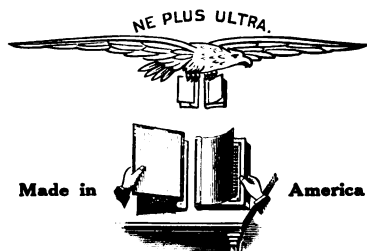

Interchangeable Leaves

BLANK ALBUMS - \$4.00 and up

STOCK BOOKS - \$2.00 and up

Used by the foremost Collectors and Dealers
Complete price list free on request



"No Plus Ultra" Watermark Revealer
Price 50c. Postage 10c. extra

All "No Plus Ultra" supplies manufactured exclusively by
SCOTT STAMP & COIN CO.
127 Madison Ave. New York City

J. M. BARTELS CO.

99 Nassau St., New York

SOLICIT from Collectors and Dealers

APPROVAL SELECTIONS

against prompt cash returns, contain-
ing any of the following items in real-
ly fine condition. They need not be
bargains.

U. S. General Issues, used and un-
used, stamps listing from 25c up,
especially older issues.

U. S. All issues in pairs, strips and
blocks, unused and used, also single
stamps (even the commonest)
showing odd cancellations or other
features of special interest.

U. S. on Original Covers, up to 1882.
Particularly odd combinations of
postage, domestic or foreign.

Confederate States. General issues
and Provisionals on or off covers.

Mexico. Selections of all issues pri-
or to 1874.

Wurtemberg,
Brunswick,
Hanover,
Oldenburg.

Fine copies only, but at good
prices; also other old Germans,
especially in pairs, strips or on cov-
ers.

Old Europeans, anything choice.

Imperf. Pairs and strips of all coun-
tries, unused or used.

Every selection containing fine ma-
terial meets with success. Let us
hear from you. Prompt returns with
check or cash.

C. G. DIETRICH
212 Broadway, New York, N. Y.

Member A. P. S., Dresden Philatelic Society, Berlin & Vienna Dealers Associations, offers his superb stock of medium and rare stamps of all countries. Moderate Prices—Fine copies only.

SPECIALTIES
British—British Colonials—used and unused

18th and 20th Century.

—Send Want List—
Approval Selections sent to responsible Collectors.

Scott's No.

St. Vincent Provisional 1915.

* One Penny on 1sh. \$1.75
* same, small O in One 3.00
* same, large ONE, in Pair with normal 7.50

Nabha State—Service 1915.

*130-138 ½, 1, 2, 4, 8a, 11r—Set 1.50
*134 4a olive Service at top—rare .75

Patala State—Service 1915.

*82-87—3 Pies, ½, 1, 2, 4, 8 annas—Set .75

Chamba States—Service.

* 60—1 Rup. carmine & green, 8 for S in State 4.00

Jhind State.

* 45—½a. green, red Surch. 5.00
* 46—2a ultramarine, red Surch. 6.00
* 47—4a green, red Surch. 9.00
* 48—1 Rup. gray, red Surch. 13.50

Jhind State—Service.

*107—½a. green, red Surch. 6.25
*108—2a ultramarine, red Surch. 7.50

*102—1a violet brown, Jhind State reversed 1.25

Nabha State.

* 10—1 Rup. gray, red Surch. 6.00
*114—1 Rup. gray, Service 6.00

Hellgoland.

* 22a 1 Mark blue green & salmon 12.00

* 22b 1 Mark deep green & carmine 6.00

* 23 5 Mark blue green & salmon 2.40

Mexico.

*147 50c yellow same without Surchage 1.80
*148 100c orange 2.50

*148 100c orange 1.80

Togo—Anglo-French Occupation.

* Half Penny on 3pf. brown 3.50

* One Penny on 5pf. green 3.50

* 20 Pfennig 3.00

* 25 Pfennig 3.50

* 30 Pfennig 3.00

The * Set of 5 values 15.00

Marshall Islands, G. R. I.

1d. on 5 Pf. green, used 6.00

* 2d. on 10 Pf. carmine 1.50

* 2d. on 20 Pf. blue 1.50

Pair last two above 2.50

German New Guinea, G. R. I.—O. S.

* 1d. on 3Pf. brown 3.00

India—Service.

*275—1 Rup. green & red brown .50

*278—5 Rup. violet & ultram. 2.50

*279—10 Rup. carmine & green 5.00

*280—15 Rup. olive green & ultramarine 7.50

*281—25 Rup. deep blue & brown orange 13.00

Biggest Philatelic Paper

Send 10c for four months, 400 pages, the oldest, largest and best collectors' monthly for all kinds of Hobbies—Coins, Stamps, Weapons, Curios, Relics, Old Books, Minerals, Sciences, Illustrated Souvenir Post Cards, Rarities and New Finds for all kinds of collectors. Over 11,000 ads. past two years.

The Philatelic West Superior, Neb.

U. S. A.

75c entitles you to a year's subscription and a free 20-word exchange notice in the largest exchange department extant.

This illustrated 100-Page Monthly was established in 1895, and has the largest circulation of any collectors' monthly in the world, and in size has no rival. More ads. in the

WEST

than in all other American Philatelic monthlies combined. The best paying medium for advertisers. Rates small, results large, 3 cents per word; 3 times at price of 2. Sample Copy Free.

If you are not a subscriber or have not seen a recent sample copy of

EVERYBODY'S PHILATELIST

You have missed something of the philatelic

Joy of Living

and have not had all "what's coming to you." We aim to be a constructive force in upbuilding philately.

4 mos. trial 10c; A year 50c; Three years \$1.00; Life subscription, \$5.00.

Ad rates 75c per inch on contract. No false claims. No exaggeration about circulation.

DR. HOLT,

Marine Hospital, San Francisco, Cal.

THE PHILATELIC GAZETTE

PUBLISHED MONTHLY FOR STAMP COLLECTORS

VOL. V, No. 11. NEW YORK, NOVEMBER, 1915. WHOLE No. 75.
COPYRIGHT, 1915, BY THE NASSAU STAMP CO.

The United States Government Collection of Postage Stamps.

BY JOSEPH B. LEAVY
Philatelist, U. S. National Museum.

(Continued.)

GREAT BRITAIN.

- 1840, Mulready envelope; 1 penny black on white, used, entire.
1840, Ornaments in upper corners, watermarked small crown, 1 penny black on white, Die I, 2 pence blue on white, Die I, used.
1841, 2 pence blue on bluish, Die I, used.
1847, 1 shilling green, used.
1848, 10 pence red brown, specimen.
1854-55, 1 penny red brown on bluish, Die I, perf. 16; 1 penny dull carmine on white, Die II, perf. 14.
1856, watermarked large crown, 1 penny rose red, Die II.
1857, 4 pence rose on white, watermarked large garter, used.
1858, watermarked heraldic emblems, 6 pence lilac, 1 shilling green, used
1858, letters in upper corners, watermarked large crown, 2 pence deep blue, specimen, 2 pence blue, specimen.
1864, 1 penny rose red, 1 penny lake red.
1862, watermarked large garter, 4 pence vermilion, hair line; watermarked heraldic emblems, 3 pence pale rose, 6 pence lilac, 9 pence straw, 1 shilling green.
1865, watermarked large garter, 4 pence vermilion; watermarked heraldic emblems, 6 pence deep lilac, 1 shilling green.
1867-69, watermarked spray of rose, 3 pence rose, 6 pence dull violet, specimen, 6 pence bright violet, used, 9 pence bistre, 10 pence red brown, 2 shillings blue.
1867, watermarked maltese cross, 5 shillings rose.
1870, watermarked half penny, ½ penny rose red, ½ penny lake red, specimen; watermarked large crown, 1 ½ pence lake red.
1872-74, watermarked spray of rose, 3 pence rose, specimen, 3 pence deep rose, specimen, 6 pence brown, used, 6 pence deep brown, used, 6 pence gray, 1 shilling green, 6 pence gray, specimen, 6 pence pale gray, specimen.
1875, watermarked anchor, 2 ½ pence claret.
1876, watermarked orbs, 2 ½ pence claret, 2 ½ pence pale claret, both specimen.
1876-77, watermarked large garter, 4 pence vermilion, 4 pence olive, 4 pence pale olive, 8 pence orange, all specimen.
1878, watermarked maltese cross, 10 shillings slate, 1 pound brown lilac, both specimen.

- 1880, watermarked orb, 2½ pence ultramarine, 2½ pence pale ultramarine; watermarked garter, 4 pence drab; watermarked spray of rose, 2 shillings brown, all specimen.
- 1881, watermarked large crown, ½ penny green, ½ penny pale green, 1 penny red brown, 1½ pence red brown, 2 pence lilac rose, 1 penny lilac, 14 dots, 1 penny pale lilac, 14 dots, 1 penny lilac, 16 dots, 1 penny pale lilac, 16 dots, all specimen.
- 1882, watermarked anchor, 5 pounds orange, 5 pounds orange on bluish, 2½ shillings lilac, 2½ shillings pale lilac, 2½ shillings lilac on bluish, all specimen.
- 1883-84, ½ penny slate, ½ penny blue slate, 1½ pence lilac, 2 pence lilac, 2 pence pale lilac, 2½ pence lilac, 3 pence lilac, 4 pence green, 4 pence pale green, 5 pence green, 6 pence green, 6 pence pale green, 9 pence green, 9 pence pale green, 1 shilling green, 1 shilling pale green, 5 shillings rose, 5 shillings pale rose, 10 shillings ultramarine, 10 shillings cobalt, 1 pound brown violet, 1 pound violet brown, all specimen.
- 1887-92, ½ penny vermilion, ½ penny dull vermilion, 1½ pence violet & green, 1½ pence violet & pale green, 2 pence green & carmine, 2 pence pale green & carmine, 2½ pence violet on blue, 2½ pence dull violet on blue, 3 pence violet on yellow, 3 pence dull violet on yellow, 4 pence brown & green, 4 pence brown & pale green, 5 pence lilac & blue, 5 pence dull lilac & pale blue, 6 pence violet on rose, 9 pence blue & lilac, 10 pence carmine & lilac, 1 shilling green, 1 shilling dull green, all specimen.
- 1891, 1 pound green, 1 pound dull green, both specimen.
- 1900, ½ penny green, ½ penny dull green, 1 shilling carmine & green, 1 shilling carmine & pale green.
- 1901-02, ½ penny gray green, 1 penny scarlet, 1½ pence violet & green, 1½ pence dull violet & pale green, 2 pence green & carmine, 2 pence dull green & carmine, 2½ pence ultramarine, 3 pence violet on yellow, 4 pence brown & green, 4 pence brown & dull green, 5 pence lilac & ultramarine, 6 pence dull violet, 9 pence ultramarine & violet, 1 shilling carmine & green, 1 shilling carmine & dull green, 2½ shillings violet, specimen, 5 shillings carmine, specimen, 10 shillings ultramarine, specimen, 1 pound green, specimen.
- 1904, ½ penny pale yellow green.
- 1909-10, 4 pence orange, 7 pence gray.
- 1911, ½ penny yellow green, 1 penny carmine rose.
- 1912-13, ½ penny green, 1 penny scarlet, 1½ pence red brown, 2 pence deep orange, 2 pence orange, 2½ pence ultramarine, 3 pence violet, 3 pence bluish violet, 4 pence slate green, 5 pence yellow brown, 6 pence dull violet, 7 pence bronze green, 8 pence black on yellow, 9 pence black brown, 10 pence light blue, 1 shilling bistre, 2½ shillings dark brown, specimen, 5 shillings carmine, specimen, 10 shillings dark blue, specimen, 1 pound green, specimen.

Postage Due.

- 1914, ½ penny emerald green, 1 penny carmine, 2 pence black, 5 pence orange brown.
- 1915, 1 shilling blue, specimen.

Official Stamps.

- I. R. Official,** 1882-85, ½ penny green, 1 penny lilac, 2½ pence lilac, 6 pence gray, 1 shilling green, 5 shillings rose, 10 shillings blue, 10 shillings cobalt, ½ penny slate blue, all specimen.
- 1888, ½ penny vermilion, 1 shilling green, both specimen.
- 1891, 2½ pence violet on blue, specimen.
- 1892, 1 pound green, specimen.
- 1900, ½ penny green, used, 6 pence violet on rose, used.
- 1902-04, ½ penny gray green, used, 1 penny scarlet, used.
- Govt. Parcels,** 1888-92, 1½ pence violet & green, 1½ pence violet & pale green, 2 pence green & carmine, 2 pence pale green & carmine, 4½

- pence carmine & green, 6 pence violet on rose, 9 pence blue & lilac, 1 shilling green, 1 shilling dull green, all specimen.
- O. W. Official**, 1890, ½ penny vermilion, 1 penny lilac.
1902, ½ penny green, used, ½ penny gray green, used, 1 penny scarlet, used, 2 pence green & carmine, used.
- Army Official**, 1896, ½ penny vermilion, 1 penny lilac, 2½ pence violet on blue.
- R. H. Official**, 1902, ½ penny gray green.
- Board of Education**, 1902, 5 pence lilac & ultramarine, used, 1 penny scarlet, 2½ pence ultramarine, used.
- Admiralty Official**, 1903, ½ penny gray green, 1 penny scarlet, 1½ pence violet & green, 2 pence green & carmine, 2½ pence ultramarine, 3 pence violet on yellow, all used.

British Offices in Turkish Empire.

- 1885-89, 40pa on 2½ pence violet on blue, 80pa on 5 pence lilac & blue, 12pi on 2½ shillings lilac, 12pi on 2½ shillings lilac on bluish, all specimen.
- 1893, 40pa on ½ penny vermilion, 40pa on ½ penny vermilion, inverted surcharge.
- 1896, 4pi on 10 pence carmine & lilac.
- 1902, 40pa on 2½ pence ultramarine, 80pa on 5 pence lilac & blue, specimen, 4pi on 10 pence carmine & violet, specimen.
- 1903-05, 12pi on 2½ shillings lilac, specimen, 24pi on 5 shillings carmine.
- 1905, ½ penny pale yellow green, 1 penny scarlet, 1½ pence violet & green, 2 pence green & carmine, 2½ pence ultramarine, 3 pence violet on yellow, 4 pence brown & green, 5 pence lilac & ultramarine, 6 pence dull violet, 1 shilling carmine & green.
- 1906, 1pi on 2½ pence ultramarine, 2pi on 5 pence lilac & blue.
- 1909-10, 30pa on 1½ pence violet & green, 1pi10pa on 3 pence violet on yellow, 1pi30pa on 4 pence brown & green, 1pi30pa on 4 pence orange, 2pi20pa on 6 pence dull violet, 5pi on 1 shilling carmine & green, specimen.
- 1910, 1¼ pi on 3 pence violet on yellow, 1¾ pi on 4 pence orange, pair; 2½ pi on 6 pence dull violet.
- 1911-12, re-engraved, ½ penny yellow green, 1 penny scarlet, 1pi on 2½ pence ultramarine.
- 1913-14, 30pa on 1½ pence red brown, 1pi on 2½ pence ultramarine, 1¼ pi on 3 pence violet on yellow, 1¾ pi on 4 pence slate green, 4pi on 10 pence light blue, 5pi on 1 shilling bistre, ½ penny green, 1 penny scarlet.

British Offices in Morocco.

- 1907, 5c on ½ penny green, 10c on 1 penny scarlet, 15c on 1½ pence violet & green, 20c on 2 pence green & carmine, 25c on 2½ pence ultramarine, 40c on 4 pence brown & green, specimen, 40c on 4 pence brown & pale green, specimen, 50c on 5 pence lilac & blue, 1p on 10 pence carmine & violet, 3p on 2½ shillings lilac, 6p on 5 shillings carmine, 12p on 10 shillings ultramarine, specimen, 20c on 2 pence pale green & carmine.
- 1907-12, ½ penny gray green, 1 penny scarlet, 2 pence green & carmine, 2 pence pale green & carmine, 4 pence brown & green, 4 pence brown & pale green, 4 pence orange, 6 pence dull violet, 1 shilling carmine & green, specimen, 1 shilling carmine & dull green, specimen, 2½ shillings lilac, specimen.
- 1910, 40c on 4 pence orange.
- 1912, 5c on ½ penny yellow green, 10c on 1 penny scarlet, 25c on 2½ pence ultramarine.
- 1914, 5c on ½ penny green, 10c on 1 penny scarlet, 15c on 1½ pence red brown, 20c on 2 pence deep orange, 25c on 2½ pence ultramarine, 1p on 10 pence light blue, 6p on 5 shillings carmine, specimen, 2½ shillings dark brown, specimen.

Cyprus.

- 1882, watermarked crown and C. C., 30pa on 1pi rose.
- 1882-84, watermarked crown and C. A., ½pi, green, Die B, specimen, 30pa lilac, Die A, 30pa violet, Die B, specimen, 1pi rose, Die B, specimen, 2pi blue, Die B, specimen, 4pi olive, Die B, specimen, 6pi olive gray, Die A, specimen, 12pi brown orange, Die A, specimen, ½ on ½pi green, Type I.
- 1894, 9pi brown & rose, 18pi slate & brown, 45pi dark violet & ultramarine, all specimen.
- 1896, ½pi green & carmine, 30pa violet & green, 1pi rose & ultramarine, 2pi ultramarine & maroon, 4pi olive green & violet, 6pi olive gray & green, 12pi brown orange & black, all specimen.
- 1903, ½pi green & carmine, 30pa violet & green, 1pi carmine & ultramarine, 2pi ultramarine & maroon, 4pi olive green & violet, 6pi olive brown & green, 9pi brown & carmine, 12pi orange brown & black, 18pi black & brown, 45pi dark violet & ultramarine, all specimen.
- 1904, multiple watermark, ½p green & carmine, 30pa violet & green, 1pi carmine & ultramarine, 2pi ultramarine & maroon, 4pi olive green & red violet, 6pi olive brown & green, 9pi brown & carmine, 12pi orange brown & black, 18pi black & brown, 45pi dark violet & ultramarine.
- 1907-08, 5pa bistre & black, 10pa orange & green, both specimen.
- 1912, 10pa orange & green, 1½pi green & carmine, 30pa violet & green, 1pi carmine & ultramarine, 2pi ultramarine & maroon, 4pi olive green & red violet, 6pi olive brown & green, all specimen; and 12pi orange brown & black.
- 1914, 18pi black & brown, 45pi dark violet & ultramarine, both specimen.

Gibraltar.

- 1886, ½ penny dull green, 1 penny rose, 2 pence brown violet, 2½ pence ultramarine, 4 pence orange brown, 6 pence violet, 1 shilling bistre, all specimen.
- 1889, August, 5c on ½ penny green, 10c on 1 penny rose, 25c on 2 pence brown violet, 25c on 2½ pence ultramarine, 40c on 4 pence orange brown, 50c on 6 pence violet, 75c on 1 shilling bistre, all specimen.
- 1889, November, 5c green, 10c rose, 25c ultramarine, 25c pale ultramarine, 40c brown orange, 50c violet, 75c olive green, 1p bistre, 5p steel blue, all specimen.
- 1895, 20c olive, 1p bistre & blue, 2p black & carmine, all specimen.
- 1898, ½ penny gray green, 1 penny carmine, 2 pence brown violet & ultramarine, 2½ pence bright ultramarine, 4 pence orange brown & green, 6 pence purple & carmine, 6 pence violet & carmine, 1 shilling bistre & carmine, all specimen.
- 1903, ½ penny green & blue green, ½ penny dull green & blue green, 1 penny violet on red, 2 pence green & carmine, 2 pence dull green & carmine, 2½ pence violet & black on blue, 6 pence violet & purple, 1 shilling black & carmine, 1 shilling gray black & carmine, 2 shillings green & ultramarine, 2 shillings dull green & ultramarine, 4 shillings violet & green, 8 shillings violet & black on blue, 1 pound violet & black on red, all specimen.
- 1904-08, multiple watermark, 6 pence violet & red violet, specimen.
- 1906-11, 1 penny scarlet, 2 pence gray, 2½ pence ultramarine, 1 shilling black on green, 2 shillings violet & blue on blue, 4 shillings black on red, 8 shillings violet & green, all specimen.
- 1912, ½ penny green, 1 penny scarlet, 2 pence gray, 2½ pence ultramarine, 6 pence dull violet & red violet, 1 shilling black on green, 2 shillings violet & ultramarine on blue, 4 shillings black & scarlet, 8 shillings violet & green, 1 pound violet & black on red, all specimen.

Morocco Agencies.

- 1898, Type I, 5c green, 10c carmine, 20c olive, 25c ultramarine, 40c orange brown, 50c violet, 1p bistre & blue, 2p black on carmine.

- 1898, Type II, 5c green, 10c carmine, 20c olive, 25c ultramarine, 40c orange brown, 50c violet, 1p bistre & blue, 2p black & carmine, all specimen.
- 1903-05, 5c gray green & blue green, 5c dull green & blue green, 10c violet on red, 20c gray green & carmine, 20c dull green & carmine, 25c violet & black on blue, 50c violet, 1p black & carmine, 1p gray black & carmine, 2p black & ultramarine, 2p gray black & ultramarine.
- 1905, multiple watermark, 5c gray green & blue green, 10c violet on red, 50c violet, 1p black & carmine, 2p black & ultramarine.

(To be continued.)

BULGARIA.

BY C. A. HOWES.

(Continued from Vol. III, page 385.)

NOTE: Among several typographical errors in the last installment of this article it seems best to point out the misspelling of the Bulgarian word for "Principality", which should properly be rendered KNIASHESTVO.

While the 1889-1901 issue of stamps, which we have just described, was in use, it was found necessary (or desirable) to issue several provisionals. The first of these was occasioned by a shortage in the 15 stotinki stamps, which were used for the local letter rate and consequently much needed, and was temporarily supplied by surcharging 1,000,000 copies of the 30 stotinki stamp. The surcharge was simply the figures "15" in short boldface type over the numerals on the stamp. The different dates are given for the issue: January 26 and February 3, 1892. As these dates do not differ by twelve days, they cannot be corresponding dates for "Old Style" and "New Style" and it is best perhaps to take the earlier.

This provisional issue is interesting as perhaps being the "stop gap" between the use of the first or Paris (?) printing of the 15 stotinki in its sheets of 180 and perforation of 13, 13½, and the local printing of the same stamp in its sheets of 100 with the 11½ or 10½ perforation, which, evidently took place in 1892 and was the first of the locally produced values.

January 26, 1892. Perforated 13, 13½.

15 on 30 stotinki, brown, black surcharge.

Toward the end of 1895, a large stock of remainders of the 2 stotinki (second type) issued in 1886 was surcharged in large red numerals "01." The printing was said to have been done in October, when the stamp was first reported, but the issue did not take place until December. The number surcharged is reported as 1,500,000. There are two sizes in the numerals of this surcharge, one of which is about twice as "thick" as the other. As far as can be determined, they do not occur on the same sheet, but belong to a different printing. The thinner numerals are the more common by far, apparently, but the thicker numerals do not seem to be at all rare. A good many sheets must have been printed with inverted surcharge as this variety is comparatively common.

December, 1895, Perforated 14½ x 15.

01 on 2 stotinki (1886), slate green, red surcharge.

Varieties:

Inverted surcharge.

Pair, one without surcharge.

About the end of February or early in March, 1901, the 10 stotinki stamps ran short and were supplied by surcharging the current 50 stotinki stamps with the figures 10 over the 10 and a short bar across the old value. The issue is stated to have been 129,000.

February (?) 1901. Perforated 13, 13½.

10 on 50 stotinki, blue green, black surcharge.

Variety: inverted surcharge.

Again in May the 5 stotinki value gave out and the rather dangerous experiment of raising the value by surcharging was tried upon the 3 stotinki stamp. The surcharge was similar to the preceding 10 on 50 stotinki, and

is also found inverted and in pair with one stamp lacking the surcharge. 200,000 are reported to have been issued.

May 1901. Perforated 13.

5 on 3 stotinki brown, black surcharge.

Varieties:—

Inverted surcharge.

Pair, one without surcharge.

This completes the story of the 1889-1901 issue, but in the meantime, there were two commemorative sets of stamps produced which we will now describe. The first was occasioned by the baptism of Prince Boris, the heir to the throne, into the Russian Orthodox Church. His father, Prince Ferdinand, was a Roman Catholic and his coming to Bulgaria, even at the call of the Bulgarian people, was offensive to Russia, who had helped win Bulgaria's independence, and recognition of Ferdinand as Prince of Bulgaria had not been given by the Russian Government. The latter was placated, however, by the baptism of the Crown Prince into the Orthodox faith and thereupon recognized Prince Ferdinand. The occasion was therefore, celebrated in proper style, even to the issuing of a set of commemorative stamps and post cards.

The stamps are of the usual size and show the princely arms in the center with the date "2nd February, 1896" arched above in Russian characters. At the top is B'LGARIA and at the bottom a circ'e with the numerals of value and STOT at each side on a ribbon. They were lithographed in sheets of 100, ten rows of ten, and perforated 13, having the shiny brown gum which the ordinary issue then had and were therefore evidently produced locally by the National Printing Office at Sofia. Mr. B. W. H. Poole says the stones were made up of twenty transfers of strips of five, each strip exhibiting minute differences in the five stamps. In the 15 stotinki stamps he finds two marked varieties: one has a thick "1" and the "5" has a curved top; the other has a thinner "1", the "5" has a straight top and both figures are slightly taller.

These stamps were printed upon the watermarked paper previously described as being used for the 2 and 3 leva stamps. The watermark covers about 54 stamps out of the 100 in the sheet.

February, 2/14, 1896. Watermarked Arms in sheet. Perforated 13.

1 stotinka, blue green.

5 stotinki, blue.

15 stotinki, violet, (2 varieties).

25 stotinki, red.

The stamps were to be in use for three months but the issue was finally continued for a year, during which time the quantities issued of each value are said to have been as follows: 1 stotinka, 3,062,000; 5 stotinki, 1,310,000; 15 stotinki, 1,022,000; 25 stotinki, 620,000.

The second commemorative set was more modest even if less beautiful (?) as it consisted of but two values, 5 and 15 stotinki, in a curious, not to say crude design. It was to commemorate the twenty-fifth anniversary of the outbreak of hostilities against the Turks, which resulted in the Turco-Russian war and the practical liberation of Bulgaria. In the center, with the rising sun as a background, is one of the crude cannon made from cherry trees that were fashioned and used with effect by the Bulgarian insurgents at the beginning of hostilities because they could obtain no better ones. The representation was doubtless made from one of the cannon still preserved in the National Museum at Sofia, and which figured in a procession during the celebration in April, 1901. The stamps were issued on April 20 and 21, (May 3 and 4, New Style) and were good for postage for a week.

The National Printing Office at Sofia was again responsible for the work which was done by lithography. Mr. Poole says the stone was made from a transfer consisting of a strip of five stamps, which are easily identified each from the other by certain small flaws. The sheet consisted of 100 stamps in ten rows of ten, on white wove unwatermarked paper, and perforated 13.

April 20-21, (May 3-4) 1901. Perforated 13.

5 stotinki, carmine (5 varieties).

15 stotinki, green, (5 varieties).

(To be continued.)

CHRONICLE OF U. S. ENVELOPES.

BY J. M. BARTELS.

| B.No. | Denom. | Die | Wmk. 15 (1907) | | Paper | Knife |
|-----------------------------|--------|-----|----------------|------|-------|-------|
| | | | Type | Size | | |
| 2185A | 2c | A2 | | 1 | Amber | 46 |
| Wmk. 18 (US-SE 1911) | | | | | | |
| 2502C | 2c | B | | 3 | Blue | 80 |
| 2502D | 2c | B | | 4 | White | 84 |
| 2612A | 2c | D | v.5 | 5 | Amber | 92 |
| 2612C | 2c | D | v.5 | 3 | Buff | 92 |
| 2669B | 2c | B | | 3 | Amber | 92 |
| Wmk. 19 (1915) | | | | | | |
| | 1c. | A | | 5 | White | 87 |
| | 1c | A | | 8 | White | 59 |
| | 1c | D | | 13 | Buff | 89 |
| | 2c | A | | 3 | Amber | 92 |
| | 2c | A | | 3 | Buff | 92 |
| | 2c | A | | 5 | Buff | 87 |
| | 2c | A | | 7 | Amber | 51 |
| Wmk. 20 (1915) | | | | | | |
| | 1c | A | | 3 | White | 80 |
| | 1c | A | | 3 | White | 92 |
| | 1c | A | | 8 | White | 59 |
| | 1c | C | v.2 | 5 | White | 87 |
| | 1c | D | | 13 | Buff | 89 |
| | 2c | A | | 14 | White | 86 |
| | 2c | B | | 7 | White | 51 |

THE POSTAL ISSUES OF AUSTRIA.

BY J. BRACE CHITTENDEN, Ph. D.

(Continued.)

FOURTEENTH ISSUE.

From July 25th, 1904 until Oct. 31st, 1908.

Types as before except that the corners containing the numerals of value are altered. On the values 1H. to 6H. the figures are in the colors of the stamps, on a white ground; 10H. to 30H. the figures are in black on a plain white ground; on 35H. to 72H. figures are in white on a ground of the same color as the stamp. Bars of shiny varnish continue. The 72H. was not issued until Nov. 7, 1904.

TABLE 36.

| | | A | | B | C | D |
|-----|-------------------|-----------|-----------|------|---|------|
| | | P. 13:12½ | P. 13:13½ | | | |
| 87 | 1H. Lilac | .08 | .01 | 7.50 | — | — |
| 88 | 2H. Gray black | .01 | .01 | — | — | 6.25 |
| 89 | 3H. Pale brown | .01 | .01 | — | — | — |
| 90 | 5H. Blue green | .02 | .01 | — | — | — |
| 91 | 6H. Orange | .02 | .01 | 7.50 | — | — |
| 92 | 10H. Rose | .03 | .01 | — | — | — |
| 93 | 20H. Light brown | .06 | .03 | — | — | — |
| 94 | 25H. Ultramarine | .08 | .03 | — | — | — |
| 95 | 30H. Red lilac | .09 | .02 | — | — | — |
| 96 | 35H. Green | .10 | .02 | — | — | — |
| 97 | 40H. Violet | .11 | .03 | — | — | — |
| 98 | 50H. Pale blue | .15 | .03 | — | — | — |
| 99 | 60H. Yellow brown | .18 | .02 | — | — | — |
| 100 | 72H. Rose | .20 | .03 | — | — | — |

The Philatelist (1908 P. 141) quotes the 2H. rouletted. Kropf adds 30H. perforation $12\frac{1}{2}$; 60H. perforation $13\frac{1}{2}:12\frac{1}{2}$ and the 50H. perforation $13\frac{1}{2}:12$.

NOTE 1. This issue replaced the preceding when the old stamps were entirely sold out and on Nov. 14th, 1905, a decree was issued dropping the lines of varnish as not having proved satisfactory. So the entire issue occurs without the bars.

FIFTEENTH ISSUE.

From Nov. 14th, until Oct. 31st, 1908.

The same in every respect as the preceding issue without the varnish bars.

TABLE 37.

| | | A | | B | | C | | D | | E | |
|-----|------------------|-----------|-----|-------|---|-----------|---|-----------|---|--------|---|
| | | P. 13:12½ | | P. 9¼ | | P. 9¼:12½ | | P. 12½:9¼ | | P. 10½ | |
| | | P. 13:13½ | | | | | | | | | |
| 101 | 1H. Lilac | .01 | .01 | 5.00 | — | 5.00 | — | 6.25 | — | | |
| 102 | 2H. Black | .01 | .01 | 7.50 | — | | — | | — | | |
| 103 | 3H. Light Brown | .01 | .01 | 2.50 | — | 6.25 | — | 6.25 | — | 1.85 | — |
| 104 | 5H. Blue green | .02 | .01 | 2.50 | — | 5.00 | — | 3.75 | — | | |
| 105 | 6H. Orange | .02 | .01 | 3.00 | — | 3.50 | — | 4.50 | — | | |
| 106 | 10H. Rose | .03 | .01 | 15.00 | — | 15.00 | — | 15.00 | — | | |
| 107 | 20H. Light blue | .06 | .02 | 15.00 | — | 15.00 | — | | — | | |
| 108 | 25H. Ultramarine | .08 | .03 | 20.00 | — | 15.00 | — | | — | | |
| 109 | 30H. Red lilac | .09 | .03 | | — | | — | | — | | |
| 110 | 35H. Green | .10 | .01 | 12.50 | — | 11.25 | — | 12.50 | — | | |
| 111 | 40H. Violet | .11 | .03 | 18.75 | — | 15.00 | — | 15.00 | — | | |
| 112 | 50H. Pale blue | .15 | .04 | 12.50 | — | 8.75 | — | 8.75 | — | | |
| 113 | 60H. Light brown | .18 | .03 | — | — | 15.00 | — | 15.00 | — | | |
| 114 | 72H. Rose | .20 | .08 | 12.50 | — | 15.00 | — | 15.00 | — | 8.25 | — |

NOTE 1. Kropf gives also the 30H. perforation $9\frac{1}{4}$ but in perforation $13:13\frac{1}{2}$ omits all but the 2, 3, 10 and 35H. I have found the 5H. and the 25H. with perforation $13:13\frac{1}{2}$, and am inclined to believe Kropf is right with respect to the others. If not, the prices in group A for this perforation are ridiculous because they are scarce. I have quoted Kohl's prices for B, C, D and E and the corresponding groups in the next issue but would not advise collecting these varieties. They are rarely found used but were either perforated for the Imperial collection or perhaps to favor some official or dealer. Occasional values are said to occur also with perforation $13:10\frac{1}{2}$.

SIXTEENTH ISSUE.

From May 14th, to Oct. 31st, 1908.

5H. with color changed; the 10, 20, 25 and 30H. with colored figures, and a new value, 12K. all with figures on a plain white ground and without varnish bars.

TABLE 38.

| | | A | | B | | C | | D | | E | |
|-----|------------------|-----------|-----|-------|---|-----------|---|-----------|---|--------|---|
| | | P. 13:12½ | | P. 9¼ | | P. 9¼:12½ | | P. 12½:9¼ | | P. 10½ | |
| | | P. 13:13½ | | | | | | | | | |
| 115 | 5H. Yellow green | .02 | .01 | 3.12 | — | 3.75 | — | 6.87 | — | 6.87 | — |
| 116 | 10H. Rose | .03 | .01 | 3.75 | — | 3.75 | — | 15.00 | — | 3.75 | — |
| 117 | 12H. Blue violet | .03 | .04 | 11.25 | — | | — | | — | 11.25 | — |
| 118 | 20H. Light brown | .06 | .01 | — | — | 15.00 | — | 15.00 | — | | |
| 119 | 25H. Ultramarine | .08 | .01 | 6.25 | — | 6.25 | — | 3.75 | — | | |
| 120 | 30H. Red lilac | .09 | .03 | | — | | — | | — | | |

See note previous issue.

SEVENTEENTH ISSUE.

1908, Jan. 1.

Designed by Prof. K. Moser and engraved by Ferdinand Schoenboeck. Issued to commemorate the 60th year of the reign of Emperor Francis Joseph I. 1H to 35H are surface printed; 50H to 10Kr. line engraved; perf. 12½, no watermark.

TABLE 39, 1908.

| | | | |
|-----|-----------------------------|------|------|
| 121 | 1H gray black | .01 | .01 |
| 122 | 2H violet | .01 | .01 |
| 123 | 3H red violet | .01 | .01 |
| 124 | 5H grass green | .02 | .01 |
| 125 | 6H buff | .02 | .01 |
| 126 | 10H rose | .03 | .01 |
| 127 | 12H scarlet | .04 | .03 |
| 128 | 20H chocolate | .05 | .01 |
| 129 | 25H dark blue | .06 | .01 |
| 130 | 30H olive green | .08 | .03 |
| 131 | 35H slate blue | .09 | .01 |
| 132 | 50H olive green | .12 | .04 |
| 133 | 60H deep carmine | .15 | .02 |
| 134 | 1Kr purple | .25 | .03 |
| 135 | 2Kr lake and olive green | .52 | .04 |
| 136 | 5Kr bistre and violet | 1.25 | .09 |
| 137 | 10Kr blue, bistre and brown | 2.65 | 1.25 |

Note 1:—Certain values were issued on a thinner paper; those known to exist are the 6H and 12H. The 50H, 60H and 1K are known in pairs imperforate between and the 2, 5, 10 and 25 unperforated. 3H, 5H, 6H, 10H, 30H and 35H come on a bluish paper of which the 3H and 5H are quoted at \$18.75 each.

Note 2:—Errors of printing due to spreading of color are catalogued as follows: 25H, "PRANCISCUS" instead of "FR" [.25 .12], occurs twice in every sheet of 100; 35H, "ERANCISCUS" instead of "FR", [.85 .75].

Note 3:—The stamps are designed to spread historical information as follows:—

- 1H Emperor Karl VI in whose reign the post formerly said to be conducted by private enterprise was first conducted by the Government (1711-1740).
- 2H Empress Maria Theresa, (1740-1780).
- 3H Emperor Joseph II, Son of Maria Theresa, (1780-1790).
- 5H Emperor Francis Joseph I, (1908) in profile.
- 6H Emperor Leopold II, son of Maria Theresa, (1790-1792).
- 10H Like the 5H.
- 12H Emperor Francis I followed his father Leopold II (1792) and as the German Emperor Francis II, until 1806. As Napoleon assumed the title of "Emperor" in 1804, Francis on Aug. 11, 1804 assumed the title "Erb Kaiser von Oesterreich" (Emperor of Austria) uniting his several possessions into one empire and ruling again under the title of Emperor Francis I, until 1885.
- 20H Emperor Ferdinand I, eldest son of Francis II (1835-1848) abdicated in favor of his nephew, Dec. 2d, 1848.
- 25H Like the 5H.
- 30H Emperor Francis Joseph I, born Aug. 18, 1830, was in his 18th year when he succeeded to the throne in 1848.
- 35H Emperor Francis Joseph I in 1878, after ruling 30 years.
- 50H Francis Joseph I in a marshals uniform.
- 60H Francis Joseph I on horseback.
- 1Kr. Francis Joseph I in imperial regalia.
- 2Kr. Front view of Schloss Schonbrunn.
- 5Kr. Hofburg Franzensplatz with the Government buildings and monument.
- 10Kr. Francis Joseph I (full face) 1908.

EIGHTEENTH ISSUE.

From Aug. 18, 1910 until Jan. 1, 1911.

A Jubilee set issued on the 80th birthday of the Emperor similar to the preceding but enlarged by labels at the top and bottom bearing dates "1830" and "1910".

TABLE 40.

| | | |
|--------------------------|------|------|
| 1H black | .25 | .25 |
| 2H violet | .30 | .30 |
| 3H red violet | .25 | .25 |
| 5H grass green | .04 | .04 |
| 6H buff | .25 | .25 |
| 10H rose | .05 | .04 |
| 12H vermilion | .25 | .25 |
| 20H chocolate | .25 | .25 |
| 25H dark blue | .10 | .12 |
| 30H olive green | .25 | .30 |
| 35H slate | .25 | .30 |
| 50H olive green | .50 | .50 |
| 60H carmine | .30 | .38 |
| 1K purple | .50 | .50 |
| 2K lake & olive green | 1.75 | 1.75 |
| 5K bistre & violet | 2.50 | 2.50 |
| 10K blue, bistre & brown | 5.00 | 5.00 |

There were three emissions of these stamps, the first on Aug. 17th, 1910, the second on Sept. 16, 1910 and the third on Dec. 2, 1910. The first lot may be distinguished either by the yellowish gum instead of white, or by the shades (especially 30H, 60H, 2Kr and 10Kr). After Jan. 1, 1911, they were demonetized but were exchangeable for the other stamps until Mar. 1, 1911.

Stamps with the postmark Aug. 18th are worth no more than the unused as the Post Office continued to use the cancellation to order in Vienna long after this date.

The 5H occurs once in each sheet with a point in "P" of post.

(To be continued.)

BELGIUM: LINE ENGRAVED STAMPS.

Notes on Classification.

By DEREK INGRAM,
Editor of "Stamp Collecting".

Plate Varieties.

The varieties of the 1st Type—retouches and re-entries (i. e. double strike, shifted transfer, misplaced roller)—are detailed below and so far as the re-entries are concerned it is obvious that practically all of these occurred in the first printing, when the work of transferring roller to plate was in operation. One of two examples, however, might be from the second or third printings—the result of some accident to the plate during the process of printing, necessitating repair.

It must be left to the student to classify these instances of retouch and re-entry according to stage of printing, for it is obviously impossible to list every slight difference in shade in juxtaposition with all the examples of retouch or re-entry. Having once classified every shade in the three distinct printings, it should not be a matter of extreme difficulty to mount the plate varieties in their proper places according to printing. In doing so, we are helped by comparison of the varieties of shade and of the paper itself.

Retouches of the Plate of 10c. First Type.

- (1) Outer frame line re-cut
- (2) Corners deepened.
- (3) Inner frame line re-cut at the upper right corner.
- (4) Similar re-cutting at the upper left corner.

Retouches of the Plate of 20c. First Type.

- (1) All corners slightly re-cut.
- (2) Extra frame line at left. (This may be the result of **Double entry**, but there is no trace of any previous transfer work on any other part of the stamp).
- (3) Lines of shading at lower left corner strongly re-cut. (This also may be result of **Double entry**, but no other parts of the impression are duplicated in this case).
- (4) Inner frame line re-cut at upper right corner (Similar to 10c).

Re-entries on the Plate of 10c. First Type.

- (1) No. 89 on plate: The original top frame line (impression of original entry) still visible about $4\frac{1}{2}$ mm. from the actual upper frame line.
- (2) No. 103 on plate: Similar line, also trace of the original inner frame line at right, inside the actual frame line and extending below the latter at the foot. Shading lines of first entry on the letters of the words "DIX CENTS".
- (3) No. 123 on plate: Traces of the shading lines of the coat, as originally entered on the plate, along the top frame line, slanting from left to right.
- (4) No. 163 on plate: Top frame line of original entry over the present frame and just outside. Figures "10" and letters "D" and "S", of "DIX CENTS", of original entry still visible.
- (5) No. 181 on plate: Lower part of the left frame line double. Upper parts of original figures "10" visible.
- (6) No. 183 on plate: Lower frame line duplicated from just outside left corner up to and including "X" of "DIX". Left frame line of original entry impressed up to level with top of the epaulette. Traces of the hair visible across the "O" and second letter "S" of "POSTES".
- (7) Plate position not identified: Extra frame line in margin of the stamp along the left half of the top frame line.
- (8) Plate position not identified: Similar to double entry of No. 123 on the plate, but fewer shading lines.
- (9) Plate position not identified: Two heavy vertical dashes, about 2mm. long in the background to the left of the head and immediately under the space between "10" and "P" of "POSTES".
- (10) Plate position not identified: Similar to No. 4 of above except that, instead of letters "D" and "S" being partly duplicated, the double entry shows the letters "DI C NTS" of "DIX CENTS" of original roller impression, in addition to line described in No. 4.

This last variety is one which I am inclined to think was the result of an imperfect repair to the plate during the second or, more probably, the third printing. The reason for this theory is that the neck frill is unshaded, which suggests that the plate had become worn. This fact alone, of course, renders the variety of more importance, and the "unshaded neck frill" is an extremely difficult stamp to find in unused condition. All the varieties enumerated above, where the plate position is given, have been identified from a proof of the left half of the sheet in black and as the "unshaded neck frill" does not appear on this proof sheet, it goes without saying that this variety was the result of some adventitious operation, as already suggested. Has any reader of the Gazette been successful in plating it?

Re-entry on the Plate of 20c. First Type.

Re-entries of the 20c are hardly ever met with. In fact, I have only seen one, which is the following:—

- (1) Trace of shading of previous entry over the first "S" of "POSTES". What appears to be the relic of a former letter "P" immediately over the letter "O" in that word—two deep parallel lines extending from the center of that letter to the outer frame line.

One would naturally expect that when the roller impressions were being made on the plate for the 20c values, the operators had by that time acquired greater delicacy and skill in the working of the apparatus. Hence, examples of re-entry of the 20c are conspicuous for their absence, with the solitary exception just described.

Accidental cuts of the Graver.

There are, however, several examples of the higher value with faint lines across the stamp in various positions. They can only be either the result of accidental cuts or slips of the graver or caused by scratches during the cleaning and wiping of the plate surface which process was necessary after each sheet of stamps was printed. In rubbing the weak solution of potash over the plate by means of a rag some "foreign body" may have been present in the latter and thus have caused the scratches referred to:—

- (1) A very distinct line across the face, above the end of the nose, and a finer line, lower down from the end of the nose to the right-hand side of the design and beyond it.
- (2) A fine slanting line extending from the right upper corner of the design across the second "S" of "POSTES" and as far as the letter "E".
- (3) A fine line from the left upper corner, right across the stamp, cutting through the tops of the letters "STES" and the figures "20" in the right upper corner.

These are similar to three of the four varieties which were described and illustrated in the Monthly Journal, October, 1913, following a contribution by Mr. Paul de Smeth on the subject. The first variety described in that journal, however is probably the solitary example of re-entry of the 20c, which I have already described.

There is no trace of any scratches, similar to the above, in the 10c stamps, and I can only ascribe the distinction to a difference in the methods of cleaning the plates, scratches being less liable to occur during the wiping of the plates for the 10 centimes. This may seem a somewhat fantastic theory but there was probably a different ingredient in the solution for cleaning the plates of the two values, for something was needed to counteract the effect of the potassium ferrocyanide and iron salt in the blue pigment.

Double Impressions of the First Type.

There seems to be evidence of one double impression of both values. By "double impression" I mean, of course, the result of a slight shift of the sheet of stamps while in contact with the printing plate. Such a variety is of course quite distinct from the examples of re-entry listed above. So far as the present limited opportunities for investigation allow, it would appear that these two double impressions are both from the first printing. One would expect this, just as one would look for examples of an imperfect knowledge of the transfer roller process principally in the early stage of working.

The two instances of double impression are:—

- (1) 10c brown, numerals duplicated—one impression very faint, about half a millimeter apart.
- (2) 20c blue, similar to 10c.

(To be continued.)

Notes on Die Proofs of the United States and Colonies.

Mr. Philip H. Ward, Jr., has just shown us a book of the die proofs of the United States, Philippines and Cuba, of unusual interest, containing many which are without doubt new to proof collectors. Besides the well known issues from 1847 to 1902 including Departments, Newspapers and Dues distributed by the Government in 1902, it also contained the following of especial interest, which we believe, are probably unique.

United States.

1902 complete in entirely different shades from those distributed in the proof books, besides copies of the 2c "shield type" and blue Special Delivery. Jamestown and St. Louis issues, complete.

Lincoln 2c, Alaska-Yukon 2c.

1908 complete in the early shades including the \$1 value in both the normal shade as well as in pink. The latter was the one first proposed but never officially approved.

Special Delivery, "Merry Widow" type in green, also two similar proofs in a dark and a light blue of an unaccepted type.

Postal Savings Card in both orange and blue.

Philippines.

The first colors from 2c to 10 pesos including the blue Special Delivery.

Most of the later shades through 10 pesos including the green Special Delivery.

Dues, the surcharged issue 1c, 2c, 3c, 5c, 10c, 30c, 50c.

Cuba.

Complete, including the Special Delivery, showing the secret marks applied by the Bureau before the dies were turned over to the Cuban Government.

NEW PLATE NUMBERS.

Through the courtesy of Mr. J. E. Ralph, Director of the Bureau of Engraving and Printing, we print herewith the full list of plate numbers to November 1st, 1915.

| No. | Den. | Class | No. | Den. | Class |
|------|------|----------|------|------|----------|
| 7559 | 1c | Ordinary | 7583 | 2c | Ordinary |
| 7560 | 2c | Book | 7584 | 2c | " |
| 7561 | 2c | Ordinary | 7585 | 1c | " |
| 7562 | 2c | " | 7586 | 2c | " |
| 7563 | 1c | " | 7587 | 2c | " |
| 7564 | 1c | " | 7588 | 2c | " |
| 7565 | 1c | " | 7589 | 2c | " |
| 7566 | 1c | " | 7590 | 2c | " |
| 7567 | 1c | " | 7591 | 2c | " |
| 7568 | 2c | " | 7592 | 1c | " |
| 7569 | 2c | " | 7593 | 2c | " |
| 7570 | 1c | " | 7594 | 2c | " |
| 7571 | 2c | " | 7595 | 2c | " |
| 7572 | 2c | " | 7596 | 1c | " |
| 7573 | 2c | " | 7597 | 2c | " |
| 7574 | 2c | " | 7598 | 4c | " |
| 7575 | 2c | " | 7599 | 4c | " |
| 7576 | 2c | " | 7600 | 4c | " |
| 7577 | 1c | " | 7601 | 2c | " |
| 7578 | 2c | " | 7602 | 1c | " |
| 7579 | 2c | " | 7603 | 2c | " |
| 7580 | 2c | " | 7604 | 2c | " |
| 7581 | 2c | " | 7605 | 2c | " |
| 7582 | 2c | " | 7606 | 4c | " |



Published the 15th day of each month

J. KLEMMANN, Jr., Editor.

CLIFTON A. HOWES, Special Contributing Editor.

JOHN A. KLEMMANN, Managing Editor.

Staff Writers.

CHARLES LATHROP PACK

VICTOR M. BERTHOLD

J. MURRAY BARTELS

DR. CARROLL CHASE

A. E. OWEN

W. B. SPRAGUE

B. W. H. POOLE

VAN DYK MACBRIDE

SUBSCRIPTION \$1.00 A YEAR, SINGLE NUMBERS 10c.

Advertising Rates

| | 1 mo. | 3 mos. | 6 mos. | 9 mos. | 12 mos. |
|------------------|--------|--------|--------|---------|---------|
| 1 inch | \$1.50 | \$4.00 | \$7.75 | \$11.50 | \$15.00 |
| ¼ p. | 5.00 | 13.50 | 26.25 | 38.00 | 50.00 |
| ½ p. | 8.50 | 23.00 | 44.50 | 65.00 | 85.00 |
| 1 page | 15.00 | 40.50 | 78.75 | 114.75 | 150.00 |

NASSAU STAMP CO., Publishers, 118 NASSAU ST., NEW YORK.

VOL. V, No. 11.

NEW YORK, NOVEMBER, 1915.

WHOLE No. 75.

EDITORIAL.

The Crawford Collection.

Collectors throughout the country will be gratified to learn that the celebrated collection of United States stamps of the Earl of Crawford has been sold to the Nassau Stamp Co. and will shortly be in America.

Much regret has often been expressed that this collection, especially rich in proofs and essays, should be the property of an Englishman and not an American, and many believed that it had been formed with a view of supplementing the celebrated Tapling Collection in the British Museum.

The Earl of Crawford is the twenty-seventh in line and did not inherit the love for philately which his father possessed. He is now serving at the front with the allies, as a surgeon.

Old time members of the Collectors Club will remember the visit of the twenty-sixth Earl in 1906 when he came over with his yacht, the Valhalla which was entered as a contestant in the Great Kaiser's Cup race, and at which time this collection was on view.

It is needless to state that all the general issues are well represented in shades, and among the postmaster issues are to be found the only known copy of the Annapolis, and a 10c Buchanan adhesive.

The carriers are practically complete, many used on original covers.

But the most interesting part of the collection is the proofs and essays which form the finest collection in existence.

The bulk of them were obtained from the late Henry G. Mandel who sold his personal collection to the Earl of Crawford for \$30,000. and as an old employee of the American Bank Note Co., had unusual facilities for gathering these proofs and essays together.

To this collection was added much other material, notably the collection

of complete sheets of proofs owned by J. A. Petrie of Phillipsburg, N. J. to whom \$15,000. was paid.

The collection is contained in 47 volumes and 7 portfolios and the arrangement of the stamps as well as the handwritten notes are the work of the Earl himself. The notes include much historical data and other general information, much of which was obtained through the efforts of the British Ambassador to this country.

The proofs are arranged in such a way as to show the stages in the development of the stamp from the first pencil sketch of the artist if possible, or other source from which the design was suggested, through each intermediate stage of the completed and accepted design.

SHORT NOTES.

U. S.—Postal Savings.

The totals of all the Postal Savings Official stamps issued together with the numbers returned to the Post Office Department when these stamps were discontinued by decree of October 5, 1914, are as follows:

| Issued | Returned |
|---------------|-----------|
| 1c—1,529,850 | 738,228 |
| 2c—3,219,950 | 1,436,083 |
| 10c—1,895,250 | 921,177 |
| 50c— 134,150 | 82,210 |
| \$1.— 123,300 | 51,180 |

All of the stamps returned were destroyed.

Pennsylvania Stock Transfer Stamps.

A contract has just been placed with a Philadelphia firm by the State Superintendent of Public Printing and Binding, the Hon. A. Nevin Pomeroy for the new State Stock Transfer Tax stamps. This will be the first time stamps of this kind will have been issued by the State of Pennsylvania.

The stamps will appear in nine denominations, 2c to \$20., and will be on sale the beginning of the new year when the tax becomes effective.

The number of stamps ordered, including all denominations is approximately 45,000,000 stamps.

U. S.—1c postage for big cities.

Senator Weeks of Massachusetts, a member of the committee on post offices and post roads, intends to introduce in Congress, a proposition for the reduction of the local delivery rate on letters from 2c to 1c in large cities.

He believes that business in this country aside from that created by the demands of the nations at war, is not really prosperous and that there is a need of a legislative course encouraging trade which would be facilitated in the larger cities by a cheaper postage rate on local delivery letters.

The Parcel Post service with Germany has been discontinued as well as the Money Order service with Belgium and Egypt. No official reasons are given.

The Washington Herald for Oct. 20th prints an interesting item regarding Miss Margaret Kerfoot of the Bureau of Engraving and Printing, chief of the division which fills and ships the orders of postage stamps to the 64,000 Post Offices throughout the United States. It is stated that during the past year, Miss Kerfoot has supervised the entire work of drawing the stamps, balancing the separate orders and shipping them to the various offices without a single error. This is all the more remarkable when it is noted that during the year, 12,000,000,000 stamps were handled by this division. The daily output is approximately 25,000,000 stamps although on a busy day as many as 205,000,000 were packed. These numbers include coil stamps for the slot machines and stamp books as well as the regular denominations.

Miss Kerfoot has been in the Department for 32 years and has held nearly every position over which she now has supervision.

THE CONFEDERATE STATES OF AMERICA.

A HISTORY OF THE GENERAL ISSUES.

BY BERTRAM W. H. POOLE.

(Continued.)



The 10 Cents, Blue.

The exact date of issue of the 10 cents value is not known but, owing to the urgency with which stamps were required, it is probable it appeared soon after the 5c. The earliest dated specimen in Mr. Klemann's collection is November 15th, 1861, which antedates the earliest date previously recorded by nineteen days. It is curious that no mention of its issue has been traced in any of the Richmond newspapers of the period but I think we may safely assign it to the latter part of October or early part of November.

The design shows a three-quarter face portrait of Thomas Jefferson, with head to right, on a lined circle. Around this is an ornamental circular band broken at the top by a small curved label, which is inscribed "CONFEDERATE STATES" in small colored capitals, and at the bottom by a similar label, which contains the words "OF AMERICA". On a straight label at the top the word "POSTAGE" appears in large uncolored capitals between two stars, while on a similar label at the base "TEN CENTS" is shown in uncolored sans-serif capitals. In each of the spandrels the numerals "10" are shown on a groundwork of arabesque pattern, while the circular band is decorated between the inscriptions with small circles and spike-shaped ornaments. The design is completed by a single-line rectangular frame. In an interesting letter published in the "Stamp Collector's Magazine" for August, 1867, Colonel H. St. George Offutt, who was First Assistant Postmaster-General and Chief of the Contract Bureau, says this stamp "was designed for James Madison, but the artist made a caricature of it". It seems more probable, however, that the portrait represents Thomas Jefferson and that it was copied from the 5c United States stamp of 1856. It is certainly a poor piece of engraving but the frame is handsome when one can find copies printed plainly enough to show all the details clearly. In the majority of specimens, unfortunately, the spandrels and background of the portrait medallion are almost solid color, the lower part of the face is little better than a smudge, and the hair is indistinguishable from the adjoining color.

This 10c value, like the 5c, was produced by lithography but the size of the sheets is not known for certain. I am inclined to the belief that this denomination was printed in large sheets of 200 divided into two panes of 100 each placed side by side. I have before me what I take to be the right hand pane. This has very large margin at right and a very small one at left varying from 2 to 2½ mm. Then I have the lower portion of what is evidently the left hand pane. This has very large margin at left and none to speak of at right. This is certainly not from the same part of the stone as the lower portion of the pane of 100 for not only are there different flaws but above the top row the frame lines of some of the stamps of the row above are shown and these are spaced quite differently from the fifth and sixth rows of the full pane. It is, of course, possible there were two stones,

each containing 100 impressions though it would seem more likely that a large stone of 200 impressions was used similar to that for the 5c. Below each of the panes the manufacturers' imprint "LITH. OF HOYER & LUDWIG, RICHMOND, VA." is shown in small almost upright sans-serif capitals. In each case the imprint begins below the space between the fourth and fifth stamps and ends below the N of CENTS on the sixth stamp. A space of about 2½ mm. separates the imprints from the bottom row of stamps.

In making the stone for this denomination the same procedure was followed as in the case of the 5c, a group of fifty transfers being made from the original die and applied four times to make the necessary 200 impressions. Each of the fifty stamps in this group of transfers shows small peculiarities so that, again as in the case of the 5c, there are fifty minutely differing types which can all be distinguished by the patient student. It is, as a matter of fact, a much easier task to "plate" this denomination than the 5c only a few specimens being really difficult to identify.

There are several small peculiarities which are common to each of the stamps in the group of fifty transfers viz.:—there is a tiny colored dot in the curved white line below the T of POSTAGE; the colored line above CONFEDERATE is doubled above the letters ON of that word; there is a colored dot or very short line above and slightly to the left of the first stroke of the N of CONFEDERATE, and a short colored line is attached to the left leg of the A of the same word, this stroke sloping downwards to the right; the A of STATES is unbarred; and the colored line under the left side of the C of AMERICA is generally broken.

The following are the distinguishing characteristics of the fifty types in each group:—

No. 1.—There is a thick smudge of color on the centre of the T of TEN.
No. 2.—There is a dot of color in the lower part of the T of TEN, and the colored line below and to the left of the same letter is bulged downwards. There is generally a small period after CENTS.

No. 3.—The upper frame line is broken above the O of POSTAGE, and the colored line under AMERICA is broken under the first stroke of the R.
No. 4.—A white flaw attached to the left and a colored dot in the right side of the T of TEN makes that letter greatly mis-shapen.

No. 5.—There is a minute uncolored dot to the left of the top serif of the P of POSTAGE, and there is a colored bulge in the right frame line about ½ mm. from the bottom.

No. 6.—Has a colored bulge as on No. 5, which also extends inwards. A semi-circular line and smudge are shown after AMERICA and a colored line severs the top of the T of TEN from the vertical stroke of that letter.

No. 7.—There are several colored dots on the T of TEN, a colored dot in the P of POSTAGE, and a colored smudge in the star at the right of that word.

No. 8.—An uncolored flaw is shown in the top left spandrel below the P of POSTAGE, and there is a colored dot in the star to the right of that word.

No. 9.—There is a slight downward bulge in the color above the T of TEN.

No. 10.—A prominent uncolored flaw joins the GE of POSTAGE.

No. 11.—An uncolored circular flaw is attached to the right of the star in the upper left corner.

No. 12.—The right frame line is broken 2mm. from the lower corner.

No. 13.—There is a colored dot in the star in the upper left corner, and a colored line runs across the inner frame line below and to the right of the S of CENTS.

No. 14.—A large uncolored flaw is attached to the right lower ray of the star in the top left corner.

No. 15.—An uncolored flaw is attached to the top of the P of POSTAGE; there is a colored line in the top of the star to the left of that word, and a dot in the middle of the star at right.

No. 16.—A bent line of color is shown in the top left star, and a thick colored line appears in the centre of the T of TEN.

No. 17.—There is a colored line across the lower part of the T of TEN, and the right vertical frame line of the value tablet is broken in the middle.

No. 18.—The inner frame line at the right is broken just below the spandrel.

No. 19.—A colored diagonal line crosses the T of TEN; there is a smudge in the star in the top left corner; and an uncolored flaw appears on the head in line with the eyes.

No. 20.—There is a colored dot in the T of TEN, another in the top of the E of the same word, and the top frame line is broken above the P of POSTAGE.

No. 21.—There is a colored dot in the T of TEN and another dot below the same letter extends across the uncolored line below the value label.

No. 22.—A faint uncolored line is attached to the right of the S of CENTS, and the right frame line is broken about 2½ mm. from the top.

No. 23.—There is a small uncolored flaw or nick in the centre of the vertical stroke of the R of CONFEDERATE.

No. 24.—A small uncolored flaw is attached to the underside of the left ray of the star in upper right corner, there is a colored line in the vertical stroke of the T of TEN, and the line is broken under the second upright stroke of the N of the same word.

No. 25.—There are two colored lines below the F of OF, another in the upper right star, and a heavy smudge in the left star. A small circular line at the right lower corner of the value label joins that label to the outer frame.

No. 26.—There is a small uncolored dot to the right of the T of TEN, and a distinct break is shown in the line below the second vertical stroke of the N of CENTS.

No. 27.—There is a large colored dot to the right of the F of OF.

No. 28.—There are two colored dots in the star in the upper right corner, there is a colored line in the left side of the T of TEN, and a break is shown in the line above the C of CONFEDERATE.

No. 29.—There is a diagonal line in the left lower part of the T of TEN, and a big dot of color is shown between the frame lines at the right just below the star.

No. 30.—A small uncolored dot is attached to the base of the T of TEN and another follows the S of CENTS. The colored line of the circle above the vertical stroke of the E of the same word is broken.

No. 31.—An almost circular flaw is shown on the background above the head.

No. 32.—There is a colored dot on the T of TEN, and a colored line projects outwards and downwards from the right frame about 1¼ mm. from the top.

No. 33.—The solid color of the value label projects slightly downwards at its right lower corner.

No. 34.—There is a colored dot in the upper part of the star in the top right corner, an uncolored flaw is attached to the right side of the T of TEN, and the right frame line is broken about 4mm. from its base.

No. 35.—There is a heavy colored dot on the T of TEN, and another below and to the left of the same letter between the frame lines.

No. 36.—There is a thick blot of color on the T of TEN, and an almost circular uncolored flaw with a colored dot in its centre is shown on the background to the right, in line with the mouth.

No. 37.—A colored line, almost circular in shape, is shown after AMERICA; there is a large colored dot between the frame lines at right, about 1mm. below the top of the right lower spandrel; and there are several colored lines or smudges across the right lower corner of the design extending as far as the S of CENTS.

No. 38.—The back of the E of POSTAGE is malformed, there is a colored dot in the star following this letter, and there is a tiny break in the right frame about 1½ mm. from the top.

No. 39.—A small colored dot is attached to the inner side of the bottom frame line below the C of CENTS, and there is a V-shaped indentation in the same line close to its right end.

No. 40.—The middle horizontal stroke of the E of POSTAGE is missing or separated from the rest of the letter, and the S of CENTS is badly shaped.

No. 41.—There is an irregularly shaped uncolored flaw below the top circular ornament in the left side of the inscribed circular band.

No. 42.—An uncolored flaw is attached to the lower side of the top right ray of the star in upper right corner.

No. 43.—A large uncolored flaw on the color below the O of POSTAGE extends into the spandrel below.

No. 44.—There is a large colored dot in the base of the T of TEN, and a short colored line or dot appears in the base of the star in the upper left corner.

No. 45.—The spike-shaped ornament between the second and third circles in the right side of the inscribed circular band is entirely devoid of color.

No. 46.—The frame lines at left are joined about 10mm. from the top by a diagonal line of color.

No. 47.—A tiny uncolored flaw is attached to the base of the T of TEN, and another is shown on the top of the P of POSTAGE.

No. 48.—An uncolored flaw attached to the bottom of the 0 of 10 in the top spandrel makes that numeral somewhat like a Q. Another small white flaw is attached to the top of the S of CENTS.

No. 49.—A large uncolored flaw extends from the right base of the T of TEN to the line below. The star in the upper right corner has a smudge across its top.

No. 50.—An uncolored flaw is attached to the lower right side of the fourth circular ornament in the right side of the inscribed circular band.

Certain stamps on the sheet have flaws by means of which their positions can be ascertained the most prominent of these being:—

Left pane (I have only seen the lower half of this.)

No. 69.—There is a large uncolored flaw between the letters TA of POSTAGE.

No. 74.—There is a circular uncolored flaw before the C of CENTS.

No. 78.—There is a large uncolored flaw below the P of POSTAGE.

No. 84.—An uncolored flaw almost entirely removes the C of CONFEDERATE.

No. 87.—There is an uncolored flaw on the background close to the cheek, just below the eye.

(To be continued.)

CANCELLATIONS.

The Wesson Device.

BY J. KLEMANN, Jr.

Since postage stamps were first introduced, many and varied have been the devices for their proper obliteration, for even from the very beginning the Postal Authorities had to guard against cleaning or the removal of the cancellation, and the use of the stamp a second time.

To avoid this loss in revenue, the Government tried many experiments, but they all had to do with the stamps themselves, and the different varieties of grills, experimental and double papers were the result.

Few indeed were the cancelling devices tried and stamps showing these experimental cancellations are exceedingly rare.

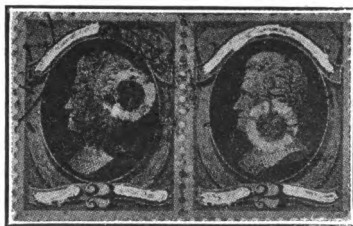

Mr. Owen recently showed us the pair of the 2c vermilion on soft paper, issue of 1879 with the cancellation from which the above illustration was taken.

This cancellation was applied with the device patented by Mr. Walter D. Wesson of Providence whose application for a patent was filed May 16, 1877 and allowed September 25, 1877, under Letters Patent Number 195,552.

The principal features of this patent are best described in the words of the patent itself.

In the accompanying drawings, like letters indicate like parts.

Figure 1 is a vertical section of my invention on the line x x. Fig. 2 is an end view, showing the face of my stamp. Figs. 3, 4, 5, 6, and 7 are detail views.

My invention is designed to be used in the canceling of postage, revenue, or other stamps. Great loss is sustained by the Government in the repeated use of stamps which have not been sufficiently canceled, and which, being removed from the envelope or paper, are cleaned of the postmarks by treatment with acid or otherwise. The use of my canceling-stamp effectually destroys the stamp and renders it worthless for further use. This is accomplished by obliterating it with ink in the usual manner, and especially by tearing out or from the stamp a portion thereof, so mutilating it that it cannot be restored.

My invention is especially designed to be used in connection with the postage-stamp invented by me, and for which I have applied for Letters Patent of the United States. That stamp is only partially gummed, leaving the central or other defined portions to lie upon without adhering to the envelope, so that the piece torn out is wholly detached and taken away from the remainder of the stamp. Useful results, however, can be obtained by the use of my invention upon stamps prepared in the usual manner.

My invention consists, essentially, in a circular perforator, within which turns (by means of a spiral slot engaged upon a fixed transverse pin) a mutilator having a series of teeth or points.

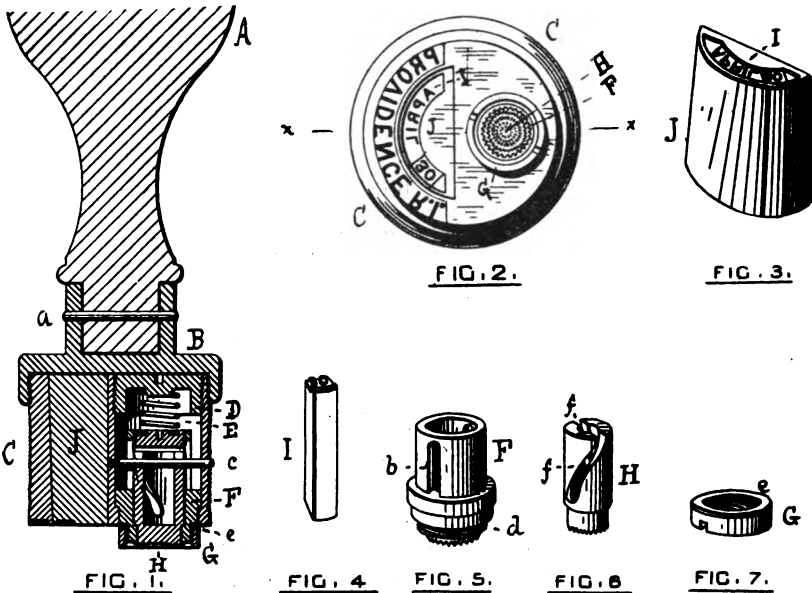

The handle A is set into and fastened within the socket B by a pin, a. The case C, which contains the working parts, is screwed into the socket B. The case C has two compartments, one for the working parts and one for the types. Within the former the nut D furnishes a bearing for the spiral spring E. This spring also bears upon and crowds outwardly the perforator F, (which is separately shown in Fig. 5.) This

perforator is tubular, and has two longitudinal slots, b, opposite each other, and has a vertical movement upon the fixed pin c, which passes from side to side through the slots b. The lower edge of the perforator consists of sharp points, which together make a circle of perforations through the stamp, and define the piece which is to be taken out. By means of a screw-thread, d, the obliterator or metallic ring G is fastened to the perforator F. An india-rubber washer, e, is placed between the perforator F and the obliterator G. Within the parts F and G, and concentric with them, is the mutilator H, (shown in Fig. 6,) having a vertical spiral motion by means of two spiral slots, f, upon the opposite sides along the fixed pin c. The face of the mutilator H is a series of sharp teeth or points, which, in turning, as above described, seize and tear out the piece of the stamp defined by the perforations, leaving a ragged edge all around, and effectually defacing and destroying the stamp. In the other compartment of the case is the type I. The types are convex on their upper long side and concave on the inner, (see Figs. 3 and 4,) and are slightly wedge-shaped. They are set within the block J, as shown in Figs. 2 and 3, and bear against the inner surface of the socket B. The name of the post-office is cut in the margin of the case C.

The operation is as follows: The parts F, G, and H project beyond the face of the case C, being crowded outwardly by the spiral spring E. The canceling-stamp, being first inked on a pad, as usual, is struck upon the postage-stamp. The obliterator G imprints the usual cancellation upon it. The perforator F at the same instant pierces the postage-stamp with a circle of perforations, and then, by the force of the blow, is driven upward within the case, traveling upon the fixed pin c by means of its vertical slots. At the same time the mutilator H, traveling on the pin c, by means of its spiral slots f, gives a slight rotary motion to the set of points or teeth, and so tears or twists out of the postage-stamp that part circumscribed by the perforations. When this work has been done the types imprint the date and name of post-office in the usual way. As the canceling-stamp is withdrawn the spiral spring brings the working parts back to their former position. The obliterator G, being screwed upon the perforator F, graduates the depth of the perforations.

The mutilating parts are preferably placed eccentrically within the circle of the face of the case C, in order to allow the date and name to be printed outside of the postage-stamp. It is obvious, however, that these working parts might be placed concentric with the postmarker.

I am aware that it is not new to use an annular cutter or knife to deface a postage stamp. Such a cutter makes a clean continuous cut, not only through the stamp, but also through the envelope itself, exposing or injuring its contents, and it is found practically impossible to graduate the cutter to so fine a distance as the thickness of a single layer of paper. When a postage stamp is gummed upon an envelope in the usual way they become so solidly united as to form but a single thickness, and a cut through one must penetrate through the other, the difference in thickness being almost inappreciable. With my improved postage stamp, for which this my canceling-stamp is particularly designed, the center of the postage-stamp, being ungummed, lies as a separate layer upon the envelope, and can be cut without injury to the envelope beneath. The perforator, indeed, has a vertical motion, but at the worst can only make a circle of fine piercings in the envelope, while the mutilator H has a horizontal rotary motion, and can affect only the outside layer of paper, which is the postage-stamp itself. The perforations are useful to enable the mutilator to tear out a certain definite piece, and to leave a ragged edge.

We have searched the Patent Office records for some trace of the patent for the improved postage stamp referred to above but without success. From the description we are inclined to think that the experiments along these lines culminated in the varieties of the 1c and 3c, known as the die cut with eight small holes, as these are the only stamps in existence which approach in any way the description of the inventor, although they do appear on an issue of stamps five years after they were first mentioned.

AUCTION REPORT.

J. C. Morgenthau & Co., 101st Sale.

MEXICO.

| Lot No. | | |
|---------|--|---------|
| 5 | 1856, ½r blue (2), block of 30, overprinted "APAM" in blue, wide setting, unused, o. g., | \$76.00 |
| 14 | — 1r orange yellow (5), overprinted "APAM" in blue, entire sheet of 60, unused, o. g. | 151.00 |
| 47 | — 8r violet without overprint (25) | 12.00 |
| 69 | 1861, 1r green with impression of a 2r on the back, the 1r overprinted "GUADALAJARA" used, | 23.00 |
| 106 | — Without overprint, 4r dull rose on yellow (43), used | 11:25 |
| 165 | 1864, 3c red brown (62a), "MEXICO 71, 1865," unused | 27.50 |
| 192 | — ½r gray lilac (64) without name, "169" "1865", irregular block of 40, unused o. g. | 135.00 |
| 211 | — 4r deep blue (67) without name, "169, 1865," block of 20, unused, o. g. | 62.50 |
| 236 | — 4r green (71) without name, "169, 1865", block of 8, unused o. g., | 36.00 |
| 246 | — Without overprint, 3c red brown (75), horizontal strip of 4, impressed from the die | 170.00 |
| 255 | 1866, Litho, 7c (84), "LAGOS 22, 1866," and sub-district "23," horizontal strip of 4, used | 24.00 |
| 256 | — — 7c pale gray (85) overprinted "62, 1866", block of 13, unused. o. g. | 31.00 |
| 312 | — Engraved, 8r green on brown (109), used | 32.00 |
| 333a | 1868, 50c black on yellow (118). "40, 68", unused, o. g. | 25.50 |
| 378 | — thick figures with period. 50c blue on pink, error (137a) overprinted "ZACATECAS 13. 69," used | 15.25 |
| 386 | 1872, "Anotado", Imperf. 50c black on yellow (143), "S L. POTOSI 5, 71," unused | 10.50 |
| 388 | — — — 100c black on brown (144), "ORIZAVA 18, 71," used | 15.00 |
| 389 | — — Perf. 6c black on brown (145), "MEXICO 1, 72," used | 10.10 |
| 406 | — Moire on back, Imperf, 100c (154), "OAXACA 20, 72", horizontal strip of 5, used | 10.75 |
| 426 | — Watermarked "Papel Sellado", Imperf., 100c lilac (164), "MATAMOROS 25, 72," used | 13.25 |
| 430 | — — Perf. 50c yellow (167a), "MEXICO 1, 72," used | 18.50 |
| 448 | 1892, 5p blue green (367 S. 230), used | 24.00 |
| 449 | — 5p scarlet (369 S. 228) used, | 17.00 |
| 450 | — 10p scarlet (370 S. 229) used. | 17.25 |
| 487 | Guadalajara, 1867, Perf. 1r dark blue, (19) used | 19.00 |

J. C. Morgenthau & Co., 102nd Sale.

| Lot No. | | |
|---------|---|-------|
| 193 | Barbados 1861 6p vermilion imperf. (20b) used | 21.00 |
| 208 | Brazil Official, 1913, 500000r brown and black (528), unused, o. g. | 26.00 |
| 209 | — — 1000000r dark brown and black (529), unused, o. g. | 55.00 |
| 210 | Bremen 1855, 3gr blue (1) on watermarked paper, used, | 16.25 |
| 222 | Canada 1852 6p purple black (5), horizontal pair, used | 12.75 |
| 223 | — 1859 2c rose imperf (18a) block of 4, part imprint at bottom, unused | 14.25 |
| 270 | Puerto Principe 5c on 1m orange brown, inverted surcharge (182a) used on piece of original, | 81.00 |
| 278 | — 5c on 8m blue green (219) used on piece of original, | 47.50 |
| 503 | Great Britain, 1840. 2p blue. (3) horizontal strip of 4. used | 14.50 |
| 561 | Greece. Mvtilene, Black Surch. Reading Up, 5pi dark violet (588) | 12.75 |
| 562 | — — 10pi dull red (589) | 21.00 |
| 673 | Indo China 1892 1fr bronze green (15) name in label double (Y. & T. 15a), unused, o. g. | 10.10 |

| | |
|---|-------|
| 684 Madagascar, French, 1895, Majunga Issue, 15c on 1f bronze green, manuscript surch in red (27d) used | 32.50 |
| 739 Oldenburg 1858 2gr rose (7) used | 29.00 |
| 802 Portugal 1862 50r blue green (15a) entire sheet of 24, used | 75.00 |
| 856 Rhodesia 1896, 1p on 3p gray and green (40), unused, o. g. | 12.75 |
| 857 — — 1p on 4s gray and vermilion (41), unused o. g. | 9.60 |
| 937 Wurtemberg 1873 70kr red violet (53) used | 18.00 |

J. C. Morgenthau & Co., 103rd Sale.

| | | |
|---|--|-------|
| Lot No. | | |
| 43 Canal Zone 1906 1c green and black, Double Surcharge, (32e) unused | | 17.50 |
| 44 — — 2c scarlet and black, Double Surcharge (33c) unused, o.g. | | 12.25 |
| 75 Colombian Republic, 1910 10p claret (372) unused, o. g. | | 13.25 |
| 106 Dominican Republic 1905, 1p black and gray (160) unused, o.g. | | 9.10 |
| 144 French Colonies in China, 1904, 1fr pale green (854) unused o.g. | | 12.25 |
| 154 — Hoi Hao, 1901, Red Surcharge 5f red lilac (965) used, | | 9.50 |
| 339 Peru 1907 2s blue and black (176) used, | | 9.50 |
| 410 Southern Nigeria, 1904, £1 purple and green (31), unused, o. g. | | 5.90 |
| 422 Spanish Guinea, 1911 1c to 10p (102 to 114) complete set, used on one cover | | 21.50 |

J. M. Bartels—56th Sale.

| | | |
|--|--|--------|
| Lot No. | | |
| 3 U. S. 1847, 10c, red bar cancellation, variety right outer line running up above design, appearing as two parallel lines at one place and thickened at another | | \$7.75 |
| 7 — 1851, 3c orange brown, first printing, pair | | 1.75 |
| 98 Bavaria, 1849, 1kr gray black, used | | 17.50 |
| 110 Hannover, 1859, 10g green, blue cancellation "UELZEN" | | 33.00 |
| 126 Mecklenburg-Strelitz 1864, 1sch, town cancellation | | 26.50 |
| 185 Canada, 1859, 10c black brown on original | | 9.60 |
| 226 Colombian Rep. 1909, Department stamp, 5p dark brown on rose used, | | 7.75 |
| 392 Nevis, 1882, 6p green unused, o. g. | | 25.25 |
| 460 Rhodesia, 1891, £10 orange brown, postally used, | | 15.50 |

NEW ISSUE NOTES.**Mexico.**

We are informed by a correspondent that the following communication was sent out in September by Cosme Hinojosa, Director General of Postes of Mexico, to the Postmaster Generals of the various countries forming the Universal Postal Union.

"The stock of postage stamps of this administration having become exhausted, and there not being adequate time for the printing of a new and final issue, this Government has deemed it necessary to put into circulation a provisional issue of postage stamps of the denominations of 1, 2, 3, 4, 5, and 10 centavos, specimens of each of which are herewith enclosed, waiving the usual method of procedure, until the International Bureau of the Universal Postal Union shall have forwarded to you a letter a copy of which is also enclosed."

"It is requested that you kindly issue the necessary instructions to your offices to accept, for distribution, all articles prepaid by means of said postage stamps. This Administration has found it necessary to issue these new stamps, and to offer them for sale immediately, in order to obviate detriment to commerce and the public."

"It is especially requested that you kindly inform me of the action taken in this matter, so that I may know what to expect."

Mexico, 1915, lithographed on coarsely woven white paper without watermark, fancy frame, alike for all values except lower label, which contains the value in words, and the rectangles in each lower corner, which contain

the numerals of value. The central circular medallion differs in each value.

- 1 centavo deep violet, imperforate. Mexican Coat of Arms.
- 2 centavos blue green, rouletted. Statue of Cuauhtemoc.
- 3 centavos light brown, rouletted. Portrait of Ignacio Zaragoza.
- 4 centavos rose carmine, rouletted. Portrait of Jose Maria Morelos.
- 5 centavos orange, rouletted. Portrait of Francisco I. Madero.
- 10 centavos bright ultramarine, rouletted. Portrait of Benito Juarez.

Trinidad.

The following incident is related in the Colonial Postmaster General's report:—

"I have here to record the fact that almost unintentionally there was a provisional issue of the local Red Cross Society's label as a ½d. postage stamp on the 18th of September last.

"It happened as follows:—His Excellency the Governor, on 17th September, 1914, was pleased to grant an application made by the local Red Cross Society that letters in connection with their work should pass through the post free of charge within the colony bearing the Red Cross stamp. On the following day about 900 envelopes containing Red Cross circulars were presented at the General Post Office by the secretary of the "Society" for distribution to country addresses, and were passed by my instructions in the ordinary way at ½d. rate, as the "Society" was anxious that these circulars should be dispatched at once, although the sub-offices had not then received instructions about them, and in order to avoid their being taxed, as they certainly would be in the usual course of business, I directed that the "Society's" label should be obliterated by the date stamp of the hour and date of posting, and I sent out a circular to all the offices informing them of what had been done, and instructing them that all letters franked by certain members of the Red Cross Committee must be passed postage free in future and until further orders, provided they had the Red Cross label affixed, but on no account must this label be obliterated again. Some time afterwards I was informed that the labels which had been obliterated on the 18th September, 1914, were considered by philatelists to constitute a provisional issue of the ½d. stamp, and I have since heard that the unused Red Cross label is now being sold freely to collectors (a fact which affords me considerable satisfaction, as the funds of the Society will benefit accordingly) and that specimens of the obliterated label of the 18th September, 1914, are in great demand, but cannot be easily obtained."

(Colonial Journal).

Portugal.

It is reported that there is in preparation for issue about Christmas time two new Assistencia stamps of a permanent design, not surcharged. The denominations are to be 1c and 2c as formerly and the stamps will be issued for Portugal and Azores as heretofore.

Macau.

The plates for an 8a have been prepared and this denomination will soon be added to the permanent set.

Cameroon.

We wish to give a note of warning regarding these stamps with overprint "G. R. I." which have proved to be bogus. Too much care cannot be exercised in collecting the G. R. I. overprints as there have been extensive frauds in this direction.

Hayti.

Three new provisionals have recently made their appearance pending the determination of the status of the Zamor issue. They consist of the 50c Nord Alexis type, 1904 issue, with large numeral 1 contained within an upright oblong, handstamped in black and in red. The same surcharge is also found in black only on the 50c, surcharged "Post Paye".

The National Philatelic War Fund of Great Britain.

GIFT FROM H. M. THE KING.

The First Fifty Donors.

In a circular issued by the Committee of the National Philatelic War Fund in July last it was announced that this movement, made in aid of the Societies of the British Red Cross and St. John of Jerusalem, had the gracious approval of His Majesty the King. To this gratifying intimation, we are able to announce an important and valuable gift from His Majesty of one of the rarest of British stamps, to be included in the auction sale. The stamp is the 9d. Great Britain (1866), plate 5, watermarked emblems, unused. This is one of the scarcest of the "abnormal" varieties of English stamps, as the nine-pence denomination was discontinued while plate 4 was still in use, and before there had been any occasion to put plate 5 to press. Only five sheets (1200 copies) of plate 5 were perforated and put into the stock of sheets of plate 4, with which they passed into circulation. Very few copies are known, but that it was issued there can be no doubt, as a used specimen on the original letter is known.

His Majesty's interesting and valuable gift forms a splendid start for the collection of stamps for the National Philatelic War Fund's Auction, and the Royal example will, no doubt, be followed by large numbers of English-speaking collectors at home and abroad.

The following are some of the notable gifts already acknowledged by the Hon. Secretaries:—

- J. B. Clarke-Thornhill. Various unused stamps, envelopes, postcards and wrappers.
- Miss Ethel M. Tanner. Six copies on piece of entire of 1d. vermilion Niger Coast, bisected and surcharged ½d. in violet (S. G. No. 60).
- Col. A. St. Leger Burrowes. Envelope and postcards.
- W. T. Wilson. Togo, Anglo-French Occupation, 1d. on 5pf., block of four of first setting with value added, 4 small "y's"; this occurs only once in a sheet of 100.
- Rev. C. Plummer. Various old stamps on entires.
- George Strode. Various uncanceled British fiscals.
- John A. Nix. Various rare stamps, including Great Britain, 2s. brown, very lightly cancelled; 3d. Sydney View; 1d. first issue Tasmania; New Zealand 6d. pelure, imperf., 6d. red-brown and brown, wmk. star, rouletted, etc., etc.
- J. C. Sidebotham. Strip of three Tuscany 20c., used, and various strips and blocks.
- H. A. Slade. Various modern high values, used, on pieces of entire.
- G. T. Pilcher. Box of stamps.
- Miss Buchanan. Small collection.
- H. Quare. Various used and unused, including set of Rhodesia 1910-12 to 5s., mint; half-sheet (150) of France, 25c. black on rose.
- J. Perrett. Two old collections, and some entires.
- H. M. Hepworth. New Zealand 3d. yellow, perf. 12 ½ x 10 (S. G. No. 238).
- Lady Anson. Orange River Colony and Transvaal V. R. I. and E. R. I.
- B. B. Tilley. Various rare stamps, including set of Sicily up to 50 grane; Nevis 4d. yellow, engraved, and ditto lithographed; British Guiana 2 on 12c. official (S. G. No. 155); Trinidad 1d. pin-perf. 14, 6d. clean cut and rough perf.; British Honduras 6d., perf. 14, unused; 3d., perf. 12 ½; and 1s., perf. 14, unused.
- A. Leon Adutt. Stock-book containing various stamps and entires.
- W. Houtzamer. Various rare stamps, including Gambia ½d. on 2s.6d., 1d. on 3s., mint; N. Nigeria, King Edward 10s., used; S. Australia 3d. on 4d., red surcharge; and seven Mafeking varieties.
- Major F. Young. Various unused British Indian and Colonials.

- Willy Jacoby. Various used and unused British and foreign stamps, including four copies of 1s. green Great Britain issue of 1887-92, overprinted I. R. OFFICIAL, unused, and two copies of the Congo 10 franc, perf. 12x14, unused.
- Harvey Clarke. Various used and unused stamps and entires (also cash donation).
- Mrs. Bryden. Various modern used and unused, and on entires.
- H. Quare (second donation). Various used and unused Antioquia, Bolivia, Belgium, and a sketch by Muirhead.
- W. Nichols. Various Great Britain.
- W. A. Harmer. Great Britain 2½d. OP, PC error, used; 5s. (Cross), 10s. and £1 (Anchor), used.
- The Misses Marechaux. An old and valuable collection.
- D. Ostara. Large part of sheet of ½d. Great Britain, Queen's head, Army official; block of four King Edward, Admiralty official; various panes.
- Rev. C. Plummer (second donation). Further lot of entires.
- J. N. Marsden. Great Britain 1887 issue in singles, pairs and blocks.
- J. M. Bartels. New Brunswick reprints, 3d., 6d. and 1s.; block of four Mexico 2 reales, Eagle; and various stamps of Cauca.
- E. W. Floyd. Twenty fine copies of Great Britain 1d. black, on entires, and pieces of original covers.
- Winch Bros. Various Greece and Roumania; and Cape and Mexican fiscals.
- T. Wickham Jones. Various American carriers', Confederate States, Victoria, Shanghai, Colombia, etc.
- Rev. H. A. James, D. D. Various used and unused Colonial and foreign.
- H. C. Mott. Various modern stamps.
- M. J. Schulte. Various used and unused.
- H. L. Hayman. A large and valuable donation, including, amongst other items, 14 entire panes of British East Africa 1890-94; six entire panes of Russian Levant (Mount Athos) including the error "ATHO"; books of Siam, Shanghai, New Zealand; and an entire with 1 peso blue and 3 pesos green Buenos Ayres.
- C. B. Horsbrugh. Various modern stamps.
- R. B. Yardley. Great Britain officials; Madeira 150r. 1879, perf. 13½, unused; Transvaal V. R. 1d. on pelure (S. G. 150); Portuguese India.
- J. N. Marsden (second donation). Sheets of ½d. on 1d. Natal; 1d. Madagascar; Macau; Portuguese India; block of seventeen 3a. British East Africa; block of thirty 10 reis Portugal, value omitted.
- Master T. F. Sandwith. Various used stamps of Great Britain, British Colonies, and foreign.
- Mr. and Mrs. J. L. Thomas. Various foreign and Colonial.
- B. W. H. Poole. Various Portuguese Indies on entires; Bolivar 1880 20c. green (error); China postage due ½c., block of 15; Dominican Republic 5s. on 1s., strip of three, showing varieties.
- Frederick Hine. Various blocks, sheets and sets, including Great Britain, Canada, Natal, New Zealand, Papua, Cape, France, Russia, Hawaiian Islands, etc.
- C. S. Warbrick. Pair of 2d. Sydney Views.
- Rev. C. Plummer (third donation). Two Oxford College and other stamps.
- J. N. Luff. Great Britain—mint pair of 4d., small corner letters, imperf., £1 green (Victoria), mint; another ditto, cancelled; £1 (Maltese Cross), cancelled; £5, mint; block of four 80 paras on 5d. King Edward, one being variety with short "0" in "80".
- F. Gillwall. Various modern Colonial and foreign stamps.
- G. J. Allis. Various valuable Colonial and foreign stamps.

As will be seen, the first fifty donations of stamps received by Mr. L. L. R. Hausburg make a splendid start for the enterprise, and it is confidently expected that every collector who can, will send either some stamps or a cheque, to help to make the grand total realised by the Fund a very real tribute and credit to the earnest endeavour of philatelists to do their share in mitigating the sufferings of our wounded soldiers.

At the meeting of the committee on October 7, the President, Mr. M. P. Castle, M. V. O., J. P., stated that he desired to emphasize the fact that the organization of the Fund was distinct from the Royal Philatelic Society, and was a movement in which all philatelists and all societies should co-operate. The premier Society in initiating the preliminary meeting did so on the understanding that the entire arrangements and control of the Fund should be directed by a body representative of all classes of British philatelists, independent of any particular philatelic society.

On the nomination of Mr. Castle, seconded by Mr. Hausburg, Mr. Fred. J. Melville was elected to the vacant (third) Hon. Secretaryship of the Fund.

The most appropriate season for the sale was discussed and the meeting decided that it was not advisable to hold the auction earlier than the middle of January next, to allow time for English speaking philatelists abroad to participate.

Although there are several months in which to accumulate the collection, it is important that collectors at home commence at once to give the lead in the matter. They should send in their donations at once, or as soon as possible, for on the principle that nothing succeeds like success a good start is of the highest importance in enabling the Committee to arouse all collectors and dealers to the necessity for doing their share.

The British philatelic societies are especially urged to make an united effort to get their members to collect stamps and cash donations for the National Philatelic War Fund. Some suggestions for the consideration of Societies will be circulated in due course.

A first list of cash donations will be published at an early date. Cheques, notes, or postal orders should be sent to the Hon. Treasurer, C. F. McNaughtan, 4 Southampton Row, London, W. C.

Gifts of stamps for sale by auction in aid of the Fund should be sent to L. L. R. Hausburg, Hon. Secretary, "Heathside," Weybridge, Surrey.

Gifts of philatelic literature may be sent to Wilmot Corfield, Hon. Secretary, 27 Longton Grove, Sydenham, S. E.

All gifts, whether of stamps, literature, or cash are acknowledged on the official numbered receipt forms of the National Philatelic War Fund Auction.

FRED. J. MELVILLE.

REVIEW.

The Standard Catalogue.

The new catalogue for 1915 made its appearance on October 29th and is a very creditable production. Throughout its pages, it shows the careful work of Mr. Luff who has eliminated the few remaining doubtful or questionable stamps, and carefully revised and verified many others.

The pricing is more nearly in accordance with prevailing market quotations, especially the standard issues, but there are still some which require careful consideration.

The present catalogue has increased 36 pages over the preceding, which in turn was 41 pages larger than the 1914 catalogue. At this rate of increase, the volume will soon become too bulky to keep it in one and it may soon have to be printed in two sections.

As a tentative proposition the publishers have put forth a de Luxe edition printed on India or bible paper, making a volume one inch thick, which is half an inch less than the volume on the regular paper.

The elimination of the 88 pages of advertising in the back of the book as well as the 33 pages of explanatory matter in the front, would have been desirable in this edition, as we believe this volume will be more in demand by advanced collectors to whom this material is of no use.

STANDARD CATALOGUE

Published by Scott Stamp & Coin Co.

127 Madison Ave., N. Y., N. Y.

XL+1016+88 pp.—octavo.

Bound in cloth 90c; \$1.00 postpaid.

De Luxe edition, bound in flexible leather, \$1.50, \$1.60 postpaid.

UNITED STATES CONFEDERATES Locals and Carriers

What Have You to Offer?

JOHN A. KLEMANN
118 Nassau St., NEW YORK

104th SALE.

U. S. & Foreign Stamps.

NOVEMBER 17, 18, 1915.

IN PREPARATION.

Collection of the late Charles Gregory

Catalogues mailed on request.

J. C. Morgenthau & Co.
87 Nassau St., New York



Interchangeable Leaves

BLANK ALBUMS - \$4.00 and up
STOCK BOOKS - \$2.00 and up

Used by the foremost Collectors and Dealers
Complete price list free on request



"Ne Plus Ultra" Watermark Revealer
Price 50c. Postage 10c. extra

All "Ne Plus Ultra" supplies manufactured exclusively by
SCOTT STAMP & COIN CO.
127 Madison Ave. New York City

ALL COLLECTORS

beginning with those graduating from the elementary stages of Philately to the most advanced have found our

Specialized Selections

as fully outlined in our free 16 page PINK LIST, not only most useful in adding to their collections, but very instructive as well. "Have taken special pleasure in studying your classification" one wrote recently.

Our very choicest stock is now embodied in these superb approval selections which have been greatly improved of late by securing first pick from many collections and constant attention to auction sales.

100 U. S. Selections

each covering a different field. Contemplate what this can mean and write for that PINK LIST describing them all, as well as some

300 Books of Foreign

Space forbids itemizing the most popular books, for instance:

- 44. U. S. General Issues. Used. Stamps from 10c to \$2.00 each. Finest copies.
- 46. Do. Special Bargains. Not the very finest copies, but 65 to 85% discount.

Let Us Hear From You.

J. M. BARTELS CO.

99 Nassau St., New York

THE PHILATELIC GAZETTE

PUBLISHED MONTHLY FOR STAMP COLLECTORS

VOL. V, No. 12. NEW YORK, DECEMBER, 1915. WHOLE No. 76.

COPYRIGHT, 1915, BY THE NASSAU STAMP CO.

The United States Government Collection of Postage Stamps.

BY JOSEPH B. LEAVY
Philatelist, U. S. National Museum.

(Continued from page 261.)

Heligoland.

- 1867-68, $\frac{1}{2}$ sch blue green & rose, Type II, 2sch rose & pale green, 6sch gray green & rose.
Reprints, $\frac{1}{2}$ sch yellow green & rose, 1sch rose & yellow green, 2sch rose & green, 2 shades, 6sch green & rose, 2 shades.
- 1869-71, $\frac{1}{2}$ sch yellow green & rose, 1sch rose & yellow green.
Reprints, $\frac{1}{2}$ sch green & rose, 1sch rose & green.
- 1873, $\frac{1}{4}$ sch pale rose & pale green, $\frac{1}{4}$ sch yellow green & rose, $\frac{3}{4}$ sch gray green & rose, 1 $\frac{1}{2}$ sch yellow green & rose.
Reprints, $\frac{1}{4}$ sch rose & green, 2 shades, $\frac{1}{4}$ sch green & rose; 2 shades, $\frac{3}{4}$ sch green & rose, 3 shades, 1 $\frac{1}{2}$ sch green & rose, 2 shades, 2sch rose & green, 2 shades, 6sch green & rose, 2 shades.
- 1875, 1pf dark rose & dark green, 2pf yellow green & dark rose, 5pf dark rose & dark green, 10pf blue green & red, 25pf rose & dark green, 50pf dull green & dark rose.
Reprints, 1pf rose & green, 3 shades, 2pf green & rose, 2 shades.
- 1876-79, 3pf green & bright red, 20pf violet carmine & yellow green, 20pf rose red & dark green.
Reprints, 3pf green & red, 3 shades.
- 1879, perforated 13 $\frac{1}{2}$ by 14 $\frac{1}{2}$, 1m dark green & vermilion, 5m blue green & salmon.

Ionian Islands.

- 1859, no watermark, ($\frac{1}{2}$ penny) orange; watermarked numeral, (1 penny) blue, (2 pence) lake.

Malta.

- 1863-74, watermarked crown and C. C., $\frac{1}{2}$ penny yellow buff, $\frac{1}{2}$ penny buff, $\frac{1}{2}$ penny golden yellow.
- 1882, watermarked crown and C. A., $\frac{1}{2}$ penny yellow buff.
- 1885, $\frac{1}{2}$ penny green, $\frac{1}{2}$ penny dull green, 1 penny carmine, 2 pence gray, 2 $\frac{1}{2}$ pence ultramarine, 4 pence brown, 1 shilling violet, 1 shilling pale violet.
- 1886, 5 shillings rose, 5 shillings deep rose.
- 1899, 4 $\frac{1}{2}$ pence black brown, 5 pence brown red, 2 $\frac{1}{2}$ shillings olive gray, 10 shillings blue black, all specimen.

- 1901, 1 farthing red brown, specimen.
 1902, 1 penny on 2½ pence dull blue, specimen.
 1903, ½ penny dark green, 1 penny carmine & black, 2 pence gray & red violet, 2½ pence ultramarine & brown violet, 3 pence red violet & gray, 4 pence brown & black, 1 shilling violet & gray, all specimen.
 1904-05, multiple watermark, 1 farthing red brown, ½ penny dull green, 1 penny carmine & black, 2 pence gray & violet, 4 pence brown & black, 4½ pence black brown, 5 pence red.
 1907-11, 1 farthing dark brown, ½ penny dark green, 1 penny carmine, 2 pence gray, 2½ pence ultramarine, 4 pence scarlet & black on yellow, 4½ pence orange, 5 pence olive green, 1 shilling black on green, 5 shillings scarlet & green on yellow, all specimen.
 1914, ¼ penny brown, ½ penny green, 1 penny scarlet, 2 pence gray, 2½ pence ultramarine, 3 pence violet on yellow, surface colored, 4 pence black, 6 pence dull violet & red violet, 1 shilling black on green, surface colored, 2 shillings ultramarine & dull violet on blue, 5 shillings red & green on yellow, 10 shillings black, all specimen.
 1915, 1 shilling black on green, colored through, specimen.

British Columbia and Vancouver Island.

- 1861, perforated 14, 2½ pence dull rose.
 1865, imperforate, 10 cents blue; perforated 14, 5c rose.
 1866, perforated 14, 3 pence blue.
 1867, perforated 14, 2 cents brown, 5 cents bright red, 25c orange; 50 cents violet, used.
 Perforated, 12½, 10 cents lilac rose; \$1. green, used, damaged.

Canada.

- 1852, imperforate, wove paper, 3p red, 6p violet, used, damaged.
 1855, imperforate, wove paper, 10p blue.
 1857, imperforate, wove paper, ½p rose, 7½p green.
 Perforated 12, ½p rose, 3p red, damaged.
 1859, 1c rose, 5c vermilion, 10c red lilac, 10c pale red lilac, 10c violet.
 1859-64, 2c rose, 12½c yellow green, 17c blue.
 1868, ½c black, 1c brown red, 1c pale brown red, 2c pale green, 2c deep green, 3c red, 3c deep red, 6c dark brown, 12½c blue, 12½c deep blue, 15c lilac, 15c pale lilac, 15c red lilac.
 1869, 1c yellow.
 1869-72, 1c yellow, 1c deep yellow, 1c pale yellow, 2c green, 2c deep green, 2c pale green, 3c dull red, 3c pale dull red.
 1872-73, 6c yellow brown, 10c rose lilac.
 1875-77, 5c olive green, 15c gray, 15c blue gray, 5c slate green, 5c dark slate green.
 1882-90, ½c black, ½c gray black, 2c blue green, 3c vermilion, 3c carmine red, used, 5c gray, 6c red brown, 10c dull rose.
 1892-93, 20c vermilion, 50c deep blue, 8c blue gray.
 1897, Jubilee, ½c black, 1c orange, 2c green, 1c yellow, 3c bright rose, 3c pale rose, 5c deep blue, 6c yellow brown, 8c dark violet, 8c dull violet, 10c brown violet, 15c steel blue, 20c vermilion, 50c ultramarine, \$1. lake, \$2. dark purple, \$3 yellow bistre, \$4 purple, \$5. olive green, the 50c to \$5. specimen.
 1897, ½c black, 1c blue green, 2c purple, 2c mauve, 3c carmine, 5c dark blue, 6c brown, 8c orange, 10c brown violet.
 1898, ½c black, 1c gray green, 2c purple, 2c dull mauve, 3c carmine, 6c brown, 8c orange, 10c brown violet, 2c lavender & carmine.
 1901, 20c olive green.
 1902, 7c olive yellow.
 1903-08, 1c gray green, 2c carmine, 2c carmine, imperforated pair, 5c blue, 7c olive bistre, 10c brown lilac, 20c olive green, 50c purple.
 1908, ½c dark brown, 1c blue green, 2c carmine, 5c dark blue, 7c olive green, 10c dark violet, 15c red orange, 20c yellow brown.
 1912, 1c dark green, 2c carmine, 5c dark blue, 7c bistre, 10c plum, 20c olive green, 50c black brown.

Registration Stamps, 1875-89, 2c orange, 5c yellow green, 8c blue.

Special Delivery, 1898, 10c blue green.

Postage Due, 1906, 1c violet, 2c violet, 5c violet.

New Brunswick.

1851, 3p red on blue, used, 6p olive yellow on blue, used, 1sh bright red violet.

1860, 1c brown violet, 1c red lilac, 5c yellow green, 10c vermilion, 12½c blue, 17c black.

1861, 2c orange, 5c brown, Greenslade Bros. counterfeit.

Nova Scotia.

1851-53, 1p red brown, 3p blue, 6p dark green.

1860-64, 1c black on yellowish, 2c lilac on white, 5c blue on yellowish, 8½c green on white, 10c vermilion on yellowish, 12½c black on yellowish.

Newfoundland.

1857, thick paper, 1p brown violet, 3p green, 5p brown violet, 6½p vermilion, used, 8p vermilion.

1860-61, thinner paper, 1p violet brown, 3p dull green, 2p orange, 4p orange.

1862, 1p reddish brown, 2p rose, 4p rose, 5p reddish brown, 5p orange brown, 6p rose, 6½p rose, 8p rose, 1sh rose.

1866, thin paper, 5c brown, used, damaged, 10c black, 12c pale red brown, 13c orange, 24c blue, 24c deep blue.

1867, medium paper, 1c violet, 2c green, 2c deep green, 10c black, 12c pale red brown.

1873, 1c brown lilac, re-engraved, 3c vermilion, 3c blue, 5c black, 6c dull rose, 6c pale dull rose.

1876, rouletted, 1c brown lilac, 3c blue, 5c blue.

1880, 1c violet brown.

†887, ½c rose red, 1c deep green, 1c gray green, 2c red orange, 3c umber brown, 5c dark blue, 10c black.

1890-95, ½c black, ½c gray black, 3c slate, 3c gray lilac, 3c slate violet, 6c carmine lake, 12c puce brown.

1896, re-issue, ½c orange red, 1c green, 3c violet brown.

1897, Jubilee, 1c deep green, 2c carmine lake, 2c dull carmine lake, 3c ultramarine, 4c olive, 4c olive green, 5c violet, 6c red brown, 6c pale red brown, 8c orange, 10c black brown, 10c purple brown, 12c dark blue, 12c deep blue, 15c scarlet, 24c gray violet, 24c deep gray lilac, 30c slate, 30c deep slate, 35c red, 35c dull red, 60c black, 60c gray black.

1897, 1c carmine rose, 1c rose carmine, 2c orange, 2c yellow orange.

1898-1900, ½c olive, ½c olive green, 1c yellow green, 2c vermilion, 3c orange, 3c yellow orange, 4c violet, 5c blue, 5c deep blue.

1908, 2c rose carmine.

1910, lithographed, 1c deep green, 2c carmine, 3c brown olive, 4c dull violet, 5c ultramarine, 6c claret, Type II, 8c pale brown, 9c olive green, 10c violet black, 12c lilac brown, 15c gray black.

1911, engraved, 6c brown violet, 8c bistre brown, 9c olive green, 10c violet black, 12c red brown, 15c slate green.

1911, Coronation, 1c yellow green, 2c carmine, 3c red brown, 4c violet, 5c ultramarine, 6c black, 8c peacock blue, 9c blue violet, 10c dark green, 12c plum, 15c magenta.

Prince Edward Island.

1861, perforated 9, 2p rose, 6p yellow green.

1865, perforated 11 to 12, 1p brown orange, 2p rose, 3p blue, 9p violet.

1868-70, 4p black.

1870, 4½p brown.

1872, 1c brown orange, 2c ultramarine, 3c rose, 4c green, 6c black, 12c violet.

British Guiana.

- 1852, 1c black on magenta, used.
Reprint, 4c black on blue.
- 1853-60, 4c blue.
Reprints, 1c vermilion, 4c blue.
- 1860-61, 1c brown red, used, damaged, 8c rose, 24c green.
Reprint, 1c pink.
- 1863, 1c black, 2c orange, 4c blue, 12c lilac, 6c blue, 24c green, 48c rose;
48c deep red, specimen.
- 1876, 1c slate, 2c orange, 4c ultramarine, 6c chocolate, 8c rose, 12c lilac,
24c green, 96c bistre, all specimen.
- 1889, 3c lilac, 4c lilac, Type I, 6c lilac, Type I, 8c lilac, 10c lilac, 20c lilac,
40c lilac, 72c lilac, \$2. green, \$3. green, \$4. green, Type I, \$5. green.
- 1889-91, 1c lilac & gray, 2c lilac & orange, 2c lilac & yellow, 4c lilac & blue,
6c lilac & maroon, 6c lilac & brown, 8c lilac & rose, 12c lilac & violet,
24c lilac & green, 48c lilac & red, 72c lilac & orange, 96c lilac & car-
mine, all specimen.
- 1890, 1c on \$2. green & black, 1c on \$2 dull green & black, 1c on \$3 green
& black, 1c on \$3 dull green & black, 1c on \$4 green & black, Type I,
1c on \$4 dull green & black, Type I.
- 1890-91, 1c green, 5c ultramarine, 5c pale ultramarine, 8c lilac & black,
all specimen.
- 1898, 1c carmine & gray, 2c blue & brown, 5c brown & green, 10c red &
blue black, 15c blue & red brown, all specimen.
- 1900, 1c gray green, 2c lilac & rose, both specimen.
- 1901-03, 2c brown & black on red, 6c gray black & ultramarine, 48c dark
gray & lilac brown, 60c gray green & carmine, all specimen.
- 1905-07, multiple watermark, 1c gray green, 2c brown & black on red, 4c
lilac & ultramarine, 5c lilac & blue on blue, specimen, 6c gray black &
ultramarine, 12c lilac & violet, 24c lilac & green, 96c black & red on
yellow, specimen, \$2.40 green & violet, specimen.
- 1907, 2c red, Type II, 4c brown & violet, 5c blue, 6c gray & black, 12c or-
ange & violet, all specimen.
- 1913-14, 1c green, 2c scarlet, 4c brown & red violet, 5c ultramarine, 6c
gray & black, 12c orange & violet, 24c dull violet & green, 48c black
& violet brown, 60c green & carmine, 72c dull violet & orange brown,
96c black & red on yellow, all specimen.
- Official Stamps, 1875, 1c black, used, 2c orange, used.

Falkland Islands.

- 1878-79, no watermark, 1p claret, 4p dark gray, 6p green, damaged, 1sh
bistre brown.
- 1884, watermarked crown and C C, 1p claret, 4p olive gray.
- 1891, watermarked crown and C A, $\frac{1}{2}$ p blue green, $\frac{1}{2}$ p green, both spec-
imen.
- 1892-96, $\frac{1}{2}$ p yellow green, 1p orange red; also 2p magenta, 2 $\frac{1}{2}$ p ultrama-
rine, 6p yellow, 6p orange, 9p vermilion, and 1sh bistre, specimen.
- 1898, 2 $\frac{1}{2}$ sh dark blue, 5sh red, both specimen.
- 1904-05, multiple watermark, $\frac{1}{2}$ p yellow green, 1p red, 2p dull violet, 2 $\frac{1}{2}$ p
ultramarine, 6p orange, 1sh bistre brown, 3sh gray green, 5sh dull red,
all specimen.
- 1912-14, $\frac{1}{2}$ p yellow green, 1p red, 2p brown violet, 2 $\frac{1}{2}$ p deep ultramarine,
6p orange, 1sh bistre brown, 3sh dark green, 5sh brown red, 10sh red
on green, £1 black on red, all specimen.
- 1915, 5sh magenta, specimen.

British Honduras.

- 1865, no watermark, 6p rose, 1sh green.
- 1872-73, watermarked crown and C C, perforated 12 $\frac{1}{2}$, 1p blue, 3p brown,
6p rose.
- 1872-74, watermarked crown and C C, perforated 14, 3p brown, 4p violet,
1sh green.
- 1884-87, watermarked crown and C A, 1p rose, 1sh gray, both specimen.

- 1888, 2c on 1p rose, type II, specimen, 3c on 3p brown, type II, specimen, 10c on 4p violet, Type II, specimen, 20c on 6p yellow, Type II, 50c on 1sh gray, Type II.
- 1891, 6c on 3p blue, specimen, 15c on 6c on 3p blue, 2c rose, 2c pale rose, specimen, 3c brown, 6c ultramarine, 6c pale ultramarine, specimen, 12c violet & green, 12c violet & yellow green, specimen, 24c yellow & blue, 24c pale yellow & pale blue, specimen.
- 1892, 1c on 1p green.
- 1895-98, 1c green, 5c ultramarine, 5c dull blue, specimen, 10c violet & green, 10c dull violet & green, specimen, 25c red brown & green, specimen.
- 1899, 50c green & carmine, 50c dull green & carmine, \$1 green & carmine, \$1 dull green & carmine, \$2 green & ultramarine, \$2 dull green & ultramarine, \$5 green & black, \$5 dull green & black, all specimen.
- 1900, 5c gray black & ultramarine on blue, specimen.
- 1901, 10c violet & green, specimen.
- 1902-04, 1c gray green & green, 2c violet & black on red, 5c gray black & ultramarine on blue, 20c dull violet & violet, all specimen.
- 1904-06, multiple watermark, 1c gray green & green, 1c green, 2c violet & black on red, 5c black & ultramarine on blue; also 10c violet & green, 25c violet & orange, 50c green & carmine, 50c dull green & carmine, \$1 green & carmine, \$2 green & ultramarine, \$2 dull green & ultramarine, \$5 green & black, and \$5 dull green & black, all specimen.
- 1909, 2c carmine, 5c ultramarine, both specimen.
- 1911, 25c black on green, specimen.
- 1913, 1c green, 2c scarlet, 5c ultramarine, 10c dull violet & olive green, 25c gray & black on green, 50c violet & ultramarine on blue, \$1 black & scarlet, \$2 green & dull violet, \$5 violet & black on red, all specimen.
- 1915, Burele overprint, 1c green, 2c scarlet, 5c ultramarine, all specimen.

(To be continued.)

THE CONFEDERATE STATES OF AMERICA.

A HISTORY OF THE GENERAL ISSUES.

BY BERTRAM W. H. POOLE.

(Continued.)

Right pane.

No. 12.—There is a small uncolored dot between the letters AG of POSTAGE.

No. 32.—A large circular uncolored flaw entirely covers the mouth and chin.

No. 34.—There is a small circular uncolored flaw on the background close to the right edge opposite the third spike-shaped ornament.

No. 37.—There is a prominent uncolored flaw on the background to the right of the mouth.

No. 52.—There is an uncolored circular flaw on the left frame by the top of the second spike-shaped ornament, and the colored centre of the first spike at the right extends into the line of the white circle.

No. 53.—There is a large colored dot outside the right frame close to the top of the right lower spandrel.

No. 68.—There is an uncolored flaw on the edge of the background by the second spike-shaped ornament at the right side.

No. 74.—There is a large uncolored circular flaw above the numerals "10" in the upper right spandrel.

No. 80.—There is a colored line through the centre of the letters AMER of AMERICA.

No. 81.—There is a large uncolored flaw on the right frame below the numerals "10" of the upper spandrel.

This 10c stamp shows considerable variation in shade, and judging by dated specimens, the deep shades represent earlier printings than the pale ones.

Although, as I shall show later, the color of this stamp was changed to red at least as early as May, 1862, and in the following July or August a change of printers was made, yet specimens of this stamp, which are unquestionable Hoyer & Ludwig productions, printed in blue and with cancellations of the later months of 1862 and early months of 1863 are not uncommon. Most of these stamps are in pale blue tints and from a worn state of the stone. This is not invariably the case, however, for I have seen copies used within a few days of each other in September 1862, one being dark and the other pale blue. I have also seen a dark blue one dated November 4th, 1862 and a pale one, of a very nice sharp impression, dated January 15th, 1863. It is a little difficult to account for these in a satisfactory manner. It is hardly possible that Hoyer and Ludwig printed any stamps later than August, 1862, when the printing contract was awarded to J. T. Paterson & Co., nor does it seem very likely that Hoyer & Ludwig printed any blue 10c stamps after the color had been changed to red in May, 1862. Dated copies are, unfortunately, of little assistance in helping to solve the many vexed problems which still envelop these stamps excepting insofar as they prove early date of use. Possibly the specimens with late dates referred to above are from sheets which were stored in the Post-office Department under the newer supplies received from the printers' instead of being issued to the post-offices in a sequence agreeing with the printers' deliveries. In many cases too, no doubt, they are isolated specimens retained by inadvertence and used months after they were purchased. It must be remembered that none of these stamps were ever demonetised by the Confederate Government so that the earliest stamps issued were good for postage at any time during the life of the Confederacy.



The 2 cents, Green.

Some time after the issue of the 5c and 10c values a 2c stamp appeared. As is unfortunately the case with so many of the stamps of the Confederate States the actual date of issue is not known. Mr. Corwin was informed that the 2c appeared about a month later than the 10c and he thereupon places its issue as January 1st, 1862. From a Postmaster's Report, dated February 28th, 1862, which was evidently not available to Mr. Corwin, it seems certain that the 2c denomination was not issued until some time in March, 1862. In this Report it is stated "Two Cent stamps have been very much needed, and it is believed the Department will be able to supply them soon." This proves that the stamps were certainly not issued before March 1st, though we may probably take it for granted that they were on sale shortly after that date. Although this 2c value was needed for prepaying the rate on drop letters and also represented the rate for newspapers and other printed matter weighing not more than 3 oz., as is shown in the official document previously quoted, it seems to have been used but sparingly. Consequently used copies are quite scarce—indeed, much rarer than catalogue quotations indicate—and I have seen none with fully dated cancellations.

The design shows a three-quarter face portrait of Andrew Jackson, with head to right, on an oval with background of horizontal and vertical lines. On a semi-circular label around the upper portion of the portrait medallion the inscription "C. S. A. POSTAGE" is shown in small uncolored capitals. The value, "TWO CENTS" is shown in colored letters on a ribbon scroll

extending across the base of the stamp; "TWO" is shown reading downwards at the left and upwards at the right on each side; and scroll and floriate ornamentation complete the design, which is, roughly, upright rectangular in shape. As with the other denominations from the Hoyer and Ludwig establishment the general effect of the design was spoiled by indifferent workmanship, the finer lines being lost in a blur of color. The color chosen for this denomination was green and variation in shade is so slight that, as Major Evans remarks, "we may safely conclude that there were very few printings of this value."

This value was evidently printed in sheets of 200 divided into two panes of 100 each (ten horizontal rows of ten) placed side by side, as was the case with the 5c and 10c denominations. The largest "piece" I have seen is a full pane of 100 in Mr. Klemann's collection. This has fairly large margin at right and narrower margin on the left, and on one part of this a minute portion of a curved line can be traced on the extreme left. This appears to be part of the design of one of the end stamps of the left hand pane and if my surmise is correct it proves the full pane to be the right hand half of a sheet and the full sheet to contain 200 impressions. The same method was followed in making up the stone as was used for the other values, i. e. the stamps were transferred in a group of fifty in five horizontal rows of ten. Unfortunately the details of the design are so indistinct that it is not possible to "reconstruct" the fifty stamps in this group of transfers but that such a group was used is proved by the presence of two rather prominent peculiarities. Between the fourth and fifth stamps of the first row there is a large smudge of color level with the base of the two small tablets containing "TWO." On the first stamp of the third row (#31) a large smudge or blot of color is shown above the upper left hand corner. The two transfer blocks forming the right hand pane are spaced about 1mm. apart—a little narrower than the space between the horizontal rows of the group of fifty designs—while on the left pane the two transfers are so close that they almost touch. I have only seen part of the left pane and on this there appear to be no flaws but on the right hand pane the following call for special mention:—

No. 2.—There is an uncolored flaw on the background in front of the nose.

No. 10.—There is an uncolored flaw between the top of the head and the O of POSTAGE, and a smaller flaw is shown at the back of the head below the T of the same word.

No. 30.—The right side of the design is badly damaged. The upper spandrel is little better than a smudge of color, and the lower one is so misshapen that the scroll ornamentation has disappeared and only the letters CE of CENTS are visible. The word TWO in the centre of the frame is quite indecipherable.

No. 40.—The ornamentation in the upper and lower right hand corners is badly misshapen.

No. 41.—An uncolored flaw removes the top of the ornamentation in the left lower spandrel.

No. 50.—There is an almost circular uncolored flaw on the color above the A of C. S. A.

No. 60.—There are two uncolored flaws on the background to the right of the portrait.

No. 66.—There is an uncolored flaw on the back of the hair in line with the O of TWO.

Nos. 91-100. (The bottom row) The "TWO CENTS" tablet at base is partly removed on each of these stamps and on #100 has almost entirely disappeared.

It is believed that there was no manufacturer's imprint on the sheets of this denomination but absolute proof is not at present forthcoming for no strips with wide bottom margin appear to be known.

The 5 Cents, Blue.

We now come to one of the most perplexing problems of any that confront the student of the postal issues of the Confederacy—the probable date at which the 5c and 10c were changed in color. A reference to any

catalogue will show that the 5c was changed in color from green to blue and the 10c from blue to red, but when these changes took place is a point concerning which no authoritative statement is forthcoming. It is generally agreed the changes took place "early in 1862" and it is also known that at a later date in the same year the 10c was again changed in color, reverting to its original tint of blue.

Mr. Corwin's theory was as follows:—

The authorities were compelled to use such ink as they could secure and in obtainable quantities as well. When the green ink, in which the first 5c stamp was printed, became exhausted, recourse was had about March 1st, 1862, to the remaining stock of blue ink. This stock in turn showed symptoms of exhaustion, and, at that time, the demand for 5c stamps being far more important than for those of 10c, it was determined to print the 5c in blue, and to utilize a supply of red ink for the 10c value, which determination was accordingly put in operation about April 1st, 1862. The arrival, however, of the typographed 5c stamps of the manufacture of Thomas De La Rue & Co., from England, a short time thereafter, enabled the printers to abandon the use of the red ink, which was very expensive and scarce, and to revert to the blue ink, which was accordingly done about August 1st, 1862."

The above reads as though the writer had based his theory on some official data, but Major Evans states this was not the case. The hypothesis that the color of the 5c was changed owing to the exhaustion of the green ink rests on nothing more substantial than conjecture, while the approximate dates at which the various changes took place are based on single dated copies—a particularly unsafe guide in the case of Confederate stamps as so few of them are legibly dated, and of these few fewer still show the year of use.

That Mr. Corwin's theory is incorrect in many respects is obvious in the light of later information. Before, however, attempting to controvert any of these statements it will be interesting to quote the theory put forward by Major Evans, viz:—

A 5 cents, **blue**, having been received from England, it would be natural enough to use **green** for the 2 cents, and when the first English supply was exhausted, and the lithographic stone of the 5 cents was again brought into use, it would be equally natural to print stamps from it in **blue**—both because that was the color of what was to be the permanent issue of that value, and because there was another value being printed in **green**. I think we may safely assume that the color of the 10 cents was changed at the same time, so as to avoid having two stamps of about the same size printed in the same color. Later still, when a further supply of the small 5 cents was received, together perhaps with a plate for printing them from, it would be safe to return to **blue** for the 10 cents, because the difference in size, and in the general appearance of the two stamps, was sufficient to prevent confusion.

Reverting again to the Postmaster's Report of February 28th, 1862, we read:—

The Department has just received from Europe * * * * 2,150,000 five cent stamps. * * * * This number, together with those being furnished by the printer in this city, will enable the Department, in a very short time, to furnish every office with a full supply.

From this we learn that the 5c De La Rue stamps arrived some time in February and that the lithographed labels were still being printed as expeditiously as possible locally. I have already shown that the 2c green was issued sometime in March and it is, therefore, only reasonable to suppose that the change of color of the 5c took place about this time and was in no way due to the exhaustion of the supply of green ink. The earliest dated specimen I have seen bears the date May 10th, 1862, so it is probable much earlier dates will be discovered. Mr. Corwin, indeed, records some as dated March 5th but as he does not state whether this shows the year or not too much reliance cannot be placed on it.

In the paragraph quoted from Major Evans' article above it is inferred that these blue 5c stamps were printed from the lithographic stone previously employed in the production of the green stamps. Mr. Melville makes a positive statement on the point, viz:—"The same stones were, of course, used as for the stamps in their original colors". I can find no evidence at all in support of this contention; on the other hand everything seems to point to an entirely new stone having been used. It is possible there may have been printings in blue from the old stone but diligent search has not resulted in the discovery of even one stamp as evidence of this possibility.

(To be continued.)

BELGIUM: LINE-ENGRAVED STAMPS.

Notes on Classification.

By DEREK INGRAM,
(Editor of *Stamp Collecting*.)

(Continued from page 268.)

Second Type.

The United States Government Collection of postage stamps is undoubtedly a magnificent one, as witness Mr. Joseph B. Leavy's exhaustive list in the *Philatelic Gazette*, but it is somewhat disappointing to find that the Post Office Department has purchased no unused examples of the earliest line-engraved stamps of Belgium. With the heavy obliterations that were used on practically all the early Belgian examples which did postal service, one is at a great disadvantage in studying the fine lines of the graver and the beauty of the impression.

Classification of the Second Type of Belgium opens up an enormous vista of philatelic possibilities, involving grouping of paper, colors, and re-touches. The first value to be mentioned is the 40 centimes issued in October 1849, which was concurrent with the 10c and 20c of the First Type until the two latter were followed by the medallion design in August 1850.

Die Proofs of Second Type.

The die engraved by Jacques Wiener for the 40 centimes soon after the issue of the First Type, had no inscription of value until after it had been officially approved. As, however, it is practically certain that the die proofs of the subsequent 10c and 20c in the medallion design were struck after the respective values had been added, it is in that case fairly safe to regard all the "blank" die proofs (i. e. proofs without denomination) as having been from the original die for the 40 centimes.

These are:—

- In black, on laid white paper
- In black, on wove white paper
- In black, on white card
- In red on laid white paper
- In red on wove white paper

With the figures and words of value added, die proofs of the 40c appear to be confined to impressions in black and in carmine on India paper,—the medium usually selected for final proof impressions from the die.

Color Trials of 10c & 20c. Second Type.

On India paper.

- 10c deep green, blue
- 20c blue, carmine, deep red, yellow, violet, orange, yellow green.

Die Proofs of 10c & 20c—Second Type.**On India paper.**

Original die—10c black, deep brown, struck in 1850 and 1866.

Original die—20c black, deep blue, struck in 1850, 1866 & 1898.

New die—10c black, deep blue, struck in 1898.

The difference between the original die and that made in 1898 is chiefly in the relation of the "D" of "DIX" to the leaves of the ornament and in the expression of the portrait.

Before leaving the subject of proofs, reference should be made to the "blank" die proof signed across the lower right corner "H. Robinson, Sc", with an added note below to the effect that the proof shows the size of the steel block upon which the postage stamps are engraved. This die proof was described and illustrated in the *Philatelic Journal of Great Britain*, November 1914 and up to the present, no explanation is forthcoming as to its status. Investigation into such a philatelic mystery is naturally a matter of extreme difficulty under existing circumstances especially as the descendant of Jacques Wiener, who is probably the only person who might be able to elucidate this mystery, is now in Bulgaria. The question, as asked by the owner of this curious proof is, "Who was this Mr. H. Robinson? Did he really engrave the die and was he in the service of Messrs. Perkins, Bacon & Co. or De La Rue & Co. and did either of these firms produce this die for Wiener and not the latter himself?"

It is to be hoped the matter may be cleared up when circumstances render it possible.

The next subject to come within the table of classification is that of plate proofs, but these are conspicuous by their absence,—at any rate, so far as access to them by philatelists is concerned. My own conviction is that proof sheets were taken of the two panes—that is one hundred impressions each, and if only these could be brought to light the discoverer would render an inestimable service to philately by making it possible to classify the numerous retouches of the plates of 10c and 20c stamps. These retouches were illustrated by Mr. Joseph B. Leavy in the *Philatelic Record*, some years ago and I cannot do better than attempt a description based on those exhaustive articles. Their position on the plate cannot, of course, be determined until we have access to the plate proofs—if such or the plates themselves still exist.

Another important point still awaiting settlement is whether the various retouches occurred before the plates were put to press or whether they were done during a later stage of the printing, owing to worn state of the plate. Mr. Leavy appears to hold the latter view, but as the retouches of Holland—also the work of Jacques Wiener—were cut before the plates were inked, it is quite likely the same thing applies to the Belgian examples. On a satisfactory settlement of this moot point depends the question of classification of the retouches according to paper and watermark.

Mr. Leavy's catalog of retouches is based on examples having the watermark without frame and if the retouches are entirely confined to this watermark, that alone, of course, is proof that the worn state of the plate necessitated the recutting.

In any case, it will be seen from the lists which are to follow that recutting was done at various stages of printing.

Retouches of Plate of 10c.

The six following are from Mr. Leavy's list:—

- (1) Outline of flames in upper corner re-cut, also of leaves above the "D" in lower corner.
- (2) Complete redrawing of leaves in lower corner (most conspicuous in third leaf from the bottom).
- (3) Complete change in the design of the leaves above the "D".
- (4) Complete redrawing of entire ornamental designs on left side of the stamp.
- (5) Leaves and flames re-cut, slightly changing outlines of each.
- (6) Complete re-cutting of outline of ornaments on right of the stamp.

The nineteen following are as noted by myself at various times.

- (7) Outer frame lines re-cut.
- (8) Outer frame lines re-cut, also re-cutting of leaves in all corners.
- (9) Outer frame lines re-cut, also re-cutting of leaves in top left corner.
- (10) Outer frame lines re-cut, also re-cutting of leaves in top right corner.
- (11) Deep extra line at left and right, outside normal line.
- (12) The same, also as per retouch No. 1.
- (13) The same, also as per retouch No. 2.
- (14) The same, also as per retouch No. 3.
- (15) The same, also as per retouch No. 4.
- (16) The same, and complete retouch of all the floral ornaments.
- (17) Lines of background deepened.
- (18) Other background lines deepened in the same way.
- (19) Ornament at foot, right, having slight line through the leaf pointing to corner.
- (20) Ornament at top, right, redrawn.
- (21) Ornament at top, right, with deep frame lines just outside the normal frame at both sides.
- (22) Inner frame lines re-cut at corners (Printing of August 1851).
- (23) The flame under the numeral at left slightly re-cut.
- (24) The same, with re-cut inner frame line.
- (25) The same, with re-cut inner frame line at corner, left only.

The list can, of course, be augmented according to individual discovery.

Retouches of the Plate of 20c.

Most of the examples of retouch on this value are practically certain to have been the result of work done over the plate before it was put to press.

Mr. Leavy states he has found seventy-five examples of retouches of the 20c and has illustrated several which answer to the following description:—

- (1) Middle portion of the leaf design in lower corner re-cut, also the inner vertical line of the frame for nearly the entire length of the stamp.
- (2) Slight re-cutting of the middle portion of the leaf design in lower corner only.
- (3) The same, with minor differences.
- (4) The same, with minor differences.
- (5) The same, with minor differences.
- (6) Outer frame line re-cut at top and bottom and the inner vertical frame line re-cut for the entire length at right.
- (7) Pronounced re-cutting of the leaf design in lower corner, also an outline re-cutting of the flames in the upper corner.
- (8) Leaves in lower corners re-cut.
- (9) The same, modified.
- (10) The same, modified.
- (11) The same, modified.
- (12) The same, modified.
- (13) The same, also retouch of the leaves close to portrait oval; background at extreme lower corner strongly re-cut.

It is impossible to tabulate all the other minor varieties, due to retouch, and there again classification must be left to the philatelist's own discretion.

Retouch of Plate of 40c.

Upper inside corner re-cut round about the circles of value. (Vide G. A. Higlett, *Philatelic Journal of Great Britain*, Nov. 1914).

Retouch of Plate of 1c.

Practically every impression, owing to weak original entry of the transfer roller.

(To be continued.)

UNITED STATES LOCAL STAMPS.

A Concise History and Memoranda.

COMPILED BY HENRY C. NEEDHAM.

(Continued.)

AMERICAN EXPRESS COMPANY.

New York City.

This Local Post was not, and is not the Express Company of that name now doing business throughout the United States and elsewhere. It was established by the firm of Smith & Dobson in the year 1856.

There was apparently considerable litigation over the name of the Company, and its life was short; so short, in fact, that the stamp issued by it is of extreme rarity.

Early in 1857 Mr. Dobson retired from the business which was thereafter, for a short time, conducted under the name of Smith's City Express Post, which later, and about November, 1858, ceased to exist on account of the Government's activity against Local Posts and the using of streets, avenues and roads contrary to the law in such case made and provided.

Various stamps have appeared as emissions of this Company. We hesitate to illustrate or acknowledge any one specimen as an authentic issue, as the counterfeits are so voluminous and of such varied type or types. The catalogue illustrates two types of the stamp but we are unable to authenticate either. We have never seen the stamp properly cancelled on cover. We note the variety below with considerable reservation, although this is the stamp claimed by Mr. J. K. Tiffany of St. Louis to be the only authentic issue of this post.

AMERICAN EXPRESS COMPANY.

Type I.

2c Green surface colored glazed paper.

AMERICAN LETTER MAIL COMPANY.

Independent Mail Route.

The proprietors of this Post were the most independent, progressive and aggressive of all the owners of the early Local Posts. They stood on the principle that any Government statute giving sole control of the postal business to the United States was unconstitutional. Mr. Lysander Spooner, the principal proprietor, before starting his business, informed the Postmaster General of the United States, so it is claimed, of his intention so to do, and added at the end of his letter: "I shall be ready at any time to answer to any suit which you may think it your duty to institute."

In the House of Representatives at Washington, on or about March 30, 1844, in replying to an inquiry addressed to the Postmaster General as to what steps had been taken for punishing infractions of the law of this Government prohibiting the establishment of private Posts or Mails, the Postmaster General referred to Mr. Spooner as follows: "One Lysander Spooner, at the head of what he has been pleased to denominate 'The American Letter Mail Company' openly established his headquarters in New York, and commenced the business of transporting letters between that City, Baltimore and other points. He proposed to do this business openly, defied the existing laws and invited a prosecution to test their constitutionality and (as he supposed generously) offered to admit all facts necessary to establish his guilt, &c., &c."

This report is on file in the general archives, and clearly shows the position of the Post in its relation to the Government.

In January, 1844, Mr. Spooner published a pamphlet of twenty pages, in which he set forth an argument as to the unconstitutionality of the laws of Congress prohibiting private mail.

On July 1st, 1845, the Government postal rates were so reduced on account of the competition of the Local Posts as to render such private competition almost unremunerative.

In 1851 appeared a pamphlet in which Mr. Spooner was referred to as the "Rowland Hill" of America, and claimed that it was mainly through his efforts that the Government reduced its postal rates in 1845 and again in 1851.

The small stamp, Type I, hereinafter noted, was engraved in sheets of 20—5 horizontal and 4 vertical. There were remainders of this stamp which later came on the market, and it is claimed that the plate is still in existence. This plate is so corroded that it would be practically impossible to produce sheets therefrom without plainly showing their re-print origin. This plate is now, or recently was, in the hands of a Boston stamp dealer.

The stamp, Type II, blue on grayish wove paper (1845) is exceedingly rare, but few copies being known to exist at this late date.

Proofs of Type I are occasionally seen and in various colors.

The cancellation used by the Post was usually by pen marks, by red blotchy hand stamps, or by the word "Paid". They used a circular hand stamp about 32½ mm. in diameter, bearing the words Forwarded by American Mail Company, date, from, and then the address of the point of origin, all within several curved lines. The point of origin, above mentioned, may have been Philadelphia, Baltimore, New York, or other points.

Type II is often found cancelled not only with manuscript lines but with the initial or name of the clerk or manager at the office of origin.



Type I



Type II

AMERICAN LETTER MAIL COMPANY.

Type I. 1844.

- 5c parchment like paper.
- 5c white wove paper.
- 5c soft porous paper.
- 5c gray wove paper.
- 5c thick heavy gray paper.

Type II. 1844.

- No value, white wove paper.
- No value, grayish wove paper.

Type II. 1845.

- No value, blue on grayish wove paper.
- (To be continued.)

THE PHILATELIC GAZETTE

Published the 15th day of each month

J. KLEMMANN, Jr., Editor.

CLIFTON A. HOWES, Special Contributing Editor.

JOHN A. KLEMMANN, Managing Editor.

Staff Writers.

CHARLES LATHROP PACK

J. MURRAY BARTELS

A. E. OWEN

B. W. H. POOLE

J. B. LEAVY

VICTOR M. BERTHOLD

DR. CARROLL CHASE

W. B. SPRAGUE

VAN DYK MACBRIDE

A. HATFIELD, Jr.

SUBSCRIPTION **\$1.00 A YEAR, SINGLE NUMBERS 10c.**

Advertising Rates

| | 1 mo. | 3 mos. | 6 mos. | 9 mos. | 12 mos. |
|--------------|--------|--------|--------|---------|---------|
| 1 inch | \$1.50 | \$4.00 | \$7.75 | \$11.50 | \$15.00 |
| ¼ p. | 5.00 | 13.50 | 26.25 | 38.00 | 50.00 |
| ½ p. | 8.50 | 23.00 | 44.50 | 65.00 | 85.00 |
| 1 page | 15.00 | 40.50 | 78.75 | 114.75 | 150.00 |

NASSAU STAMP CO., Publishers, 118 NASSAU ST., NEW YORK.

VOL. V, No. 12.

NEW YORK, DECEMBER, 1915.

WHOLE No. 76.

EDITORIAL.

Another volume of the GAZETTE is completed with this number and we cannot help but look back with considerable satisfaction upon our efforts to maintain the high standard of this publication since its inception; this too, in a year which has been more than usually disastrous to publishers of philatelic papers.

During the two years we have published the GAZETTE we have gained many ideas in regard to what a philatelic publication should be and it is our purpose to put these ideas in operation as soon as we conveniently can but it all depends on the support we receive from our readers on the one hand, and advertisers on the other. For the coming year we would like to see at least several more pages of advertising matter. We will give this subject considerable thought, and the probabilities are, we will be able to offer our readers something additional along these lines. In order, however, to accomplish this, it is necessary that advertisers obtain results and that they do we know from our own experience as well as that of others who have used our pages.

We also need an increased circulation. This, we know is the usual cry among publishers whose chief idea is to make a publication pay huge profits. This however is not our idea in the main, so far as the GAZETTE is concerned. Our purpose is to produce a publication of original articles on timely subjects giving the latest and best information and results of original research in philately.

Why not help us increase this circulation—each subscriber getting another—for only as our circulation increases can we enlarge our publication and bring it up to the standard to which we aspire.

We wish all our readers a most happy Christmas and prosperous New Year.

SHORT NOTES AND NEWS.

John A. Klemann of the Nassau Stamp Co. sailed for England on November 22nd for the purpose of bringing over the Crawford Collection which was recently purchased by them.

Mr. R. H. Mower, who recently returned from a trip to Australia writes us as follows:

South Australia—1855-60, 6d.

The best catalogs list the 6 pence London print in one shade only. In the lot found in South Australia, there were three shades on two papers—thick and thin. Naturally a worn plate and a shifted die appeared to round out that issue.

In the Adelaide print the catalogs list one shade imperf. and two rouletted.

The slate blue comes in marked shades and on two papers imperforate and rouletted. The violet blue or second local printing comes imperforate as well as rouletted and is very scarce in the former state. It was issued late in 1853. This local print also comes in a blue shading to ultramarine on very thin paper.

This common cancellation is of a circle of parallel bars with a small circle or diamond in the center. Black is commonest and blue a little scarce. Dated cancellations are scarce also as they were supposed to follow the envelope and the killers on the stamp. Blue and black about equal in the dated cancellations.

In the article on "Notes on Die Proofs etc." on page 269 our attention was called to the 2c shield type, Jamestown and St. Louis issues; also the Philippines, first colors from 2c to 10 pesos including the blue special delivery as being in the Government collection; also to the existence of another similar book.

ENVELOPE NOTES AND CHRONICLE.

BY J. M. BARTELS.

Most envelope collectors are familiar with the two new watermarks under the 1915 contract, which were illustrated on page 188 of the Philatelic Gazette. Another variety similar to 19 and 20 is now in use. The year date 1915 appears horizontally at the bottom of the monogram. It has only been seen on manila envelope and wrappers, and in all probability will be used on manila exclusively, thus giving its manufacturer a distinguishing watermark. It has been assigned No. 21.

NEW ISSUES & DISCOVERIES

| B.No. | Denom. | Die | Type | Size | Paper | W | mk. | Kn. |
|-------|--------|-----|------|------|--------|---|-----|--------------|
| 91aa | 3c | — | 14 | 2 | Buff | | 1 | 7 |
| 147ii | 2c | D | 34 | 3 | Orange | | 1 | 11 |
| 2612 | 2c | D | 5 | 3 | White | | 17 | 92 |
| 2647 | 1c | D | | 5 | Amber | | 18 | 87 |
| 2670B | 2c | B | | 5 | Buff | | 18 | 87 |
| | 1c | A | | 13 | Buff | | 19 | 89 |
| | 1c | C | 1 | 8: | Amber | | 19 | 59 |
| | 1c | D | | 5 | Amber | | 19 | 87 |
| | 2c | A | | 7 | Blue | | 19 | 51 |
| | 2c | A | | 14 | Amber | | 19 | 93 (new kn.) |
| | 2c | E | | 13 | Buff | | 19 | 89 |
| | 5c | B | | 5 | Amber | | 19 | 87 |
| | 1c | A | | 8 | White | | 20 | 91 |
| | 2c | A | | 14 | White | | 20 | 86 |
| | 2c | A | | 14 | Amber | | 20 | 93 |
| | 2c | C | | 8 | White | | 20 | 91 |
| | 2c | E | | 5 | Amber | | 20 | 87 |
| | 1c | A | | 6: | Manila | | 21 | 75a |
| | 1c | A | WR. | | Manila | | 21 | WR. 5 |

BOLIVAR.

The Stamps of 1879-1899.

By A. HATFIELD, JR., and BERTRAM W. H. POOLE.

(Continued.)

VIII.—The 1884 Issue.

The issue for 1884 does not appear to have been chronicled until quite late in the year, so it is hardly likely the stamps were on sale before September. In design the stamps are precisely similar to those of 1883 with the single exception of the date. With the change of date a return was made to the sheets of fifty only—at least, all we have seen are of that size. While it is possible the same method was followed in laying down the lithographic stones, i. e. the use of two transfers, we have been unable to find any evidence in support of this supposition so far as the 10c, 20c, 80c and 1 peso values are concerned. Any differences which may exist have quite eluded our vigilance though for the 5c and 40c denominations two transfers were undoubtedly used.

1884

5 centavos

40 centavos



5 centavos

1885

40 centavos



The 5 centavos.

The two types of this value may be distinguished by the following small differences:—

Type 1.—The upper and lower frame lines of the left hand shield are broken at their left ends where they should join the vertical frame line, and the double frame lines, adjacent to this shield, are closed making a point of the ends.

Type 2.—The lines of the shield are not broken.

The two types are arranged on the sheets as follows:—

| | | | | | | | | | |
|---|---|---|---|---|---|---|---|---|---|
| 1 | 1 | 1 | 2 | 2 | 2 | 2 | 2 | 2 | 2 |
| 2 | 2 | 2 | 2 | 2 | 2 | 2 | 2 | 2 | 2 |
| 1 | 1 | 1 | 1 | 1 | 1 | 1 | 2 | 1 | 2 |
| 1 | 1 | 1 | 1 | 2 | 2 | 2 | 2 | 2 | 2 |
| 2 | 1 | 1 | 1 | 1 | 1 | 1 | 1 | 2 | 1 |

There are, thus, 23 of type 1 and 27 of type 2 in each sheet—a proportion not found on any of the values of the preceding issue.

The 40 centavos.

The two types of this value differ as follows:—

Type 1.—There is a widening of the white space between the background and the fine circular line of color at the sixth line above the right upper corner of the left shield. The lower right line of this shield is generally missing, though sometimes a faint dotted line is shown and this extends to below the lower point of the shield.

Type 2.—There is no defect in the background as in type 1, and the line at the lower right of the left shield shows more plainly although it is generally more or less broken.

The sheet arrangement of the types is as follows:—

| | | | | | | | | | |
|---|---|---|---|---|---|---|---|---|---|
| 1 | 1 | 1 | 2 | 1 | 2 | 1 | 2 | 2 | 1 |
| 2 | 2 | 2 | 2 | 2 | 1 | 1 | 1 | 2 | 1 |
| 2 | 1 | 1 | 1 | 2 | 2 | 2 | 1 | 1 | 2 |
| 2 | 2 | 1 | 1 | 1 | 1 | 1 | 2 | 1 | 2 |
| 2 | 2 | 1 | 2 | 2 | 2 | 1 | 1 | 2 | 2 |

Each sheet of the 40c, therefore, contains 24 specimens of type 1 and 26 of type 2.

Paper.

All the stamps of this series were printed on ordinary white wove paper.

Perforation.

Evidently the same perforating machines continued in use for we find all six values perforated 12 all round and also with the compound perforation of 16 by 12 as in the case of the preceding issues of similar design. The 5c perf. 16 by 12 is known in horizontal pairs imperforate between.

Imperforate varieties.

The 5c and 1 peso are both known entirely imperforate and, as in the case of similar unfinished stamps of Bolivar we have no reason to imagine they were ever sold for use in this condition.

IX.—The 1885 Issue.

Although the authorities responsible for Bolivar's stamp production started out with the "laudable" idea of having a new series every year; distinctively dated, they managed to get a little behindhand, for, as we have already shown, the 1883 and 1884 sets did not appear until quite late in those years respectively. However, the State made up for this procrastination with the issue now under notice, for the 5c of 1885 was in use at least as early as May, 1884, and the 10c was issued in October of the same year.

When the balance of the set appeared is a moot point, for these date differences seem to have been one too many for the new issue chroniclers of the period. Lithography was again the method employed in the manufacture of these stamps and a study of the sheets is rather interesting for some contain fifty and some forty stamps as in the issue of 1883.

The 5 centavos.

This value exists in two distinct settings. One of these, consisting of fifty stamps to the sheet shows no type varieties while the other, containing forty stamps, shows that two different transfers were used in its makeup. These differ as follows:—

Type 1.—The shield at right is properly outlined, while there is no outer frame line where the left shield touches the border.

Type 2.—The shield at right is broken at top and bottom so that the white circular band runs through it; the frame at left is complete, and there is a curious colored flaw above the N of CINCO.

The two types are distributed in the sheets as follows:—

| | | | | | | | | | |
|---|---|---|---|---|---|---|---|---|---|
| 1 | 1 | 2 | 2 | 1 | 2 | 2 | 2 | 2 | 2 |
| 2 | 1 | 1 | 2 | 2 | 2 | 2 | 2 | 2 | 1 |
| 2 | 1 | 2 | 2 | 2 | 2 | 2 | 2 | 2 | 1 |
| 1 | 1 | 1 | 1 | 1 | 1 | 1 | 1 | 1 | 1 |

Each sheet therefore contains 18 specimens of type 1 and 22 of type 2. The sheets of fifty are all of type 1.

The 10 centavos.

The 10c value is also found in sheets of fifty and forty. Both were printed from the same stone, but in printing the smaller sized sheets the lower row of designs was partly covered or removed. Possibly two transfers were used but we can only find evidence of one. Every stamp on each sheet shows the following small peculiarities: A dot on the "0" of "10" at the base of that numeral; a smudge of color below the third star, and a dot in front of the sixth; two dots, like a widely spaced colon, between the letters "EZ" of "DIEZ"; while a colored, but not continuous line extends from below the E of CORREOS across the shading to a point in front of the eye.

The 20 centavos.

The 20c denomination may also be found in sheets containing both forty and fifty stamps and, like the 10c, there appears to be but one type.

The 40 centavos.

Sheets of both fifty and forty exist for this value both being printed from the same stone which was made up from two different transfers. These may be distinguished as follows:—

Type 1.—The left side of the left shield is distinctly double lined, and the lower right outline is broken. The line at the top of the same shield projects through the left hand border. There is a colored dot above the "5" of the date.

Type 2.—The left hand shield is normal and there is no dot above the "5".

The disposition of the types in the sheet is shown on the following diagram:—

| | | | | | | | | | |
|---|---|---|---|---|---|---|---|---|---|
| 2 | 1 | 2 | 2 | 1 | 1 | 2 | 2 | 1 | 1 |
| 1 | 2 | 2 | 1 | 2 | 2 | 1 | 1 | 1 | 2 |
| 1 | 1 | 1 | 2 | 2 | 1 | 2 | 2 | 2 | 1 |
| 2 | 2 | 1 | 1 | 1 | 1 | 2 | 1 | 2 | 1 |
| 1 | 2 | 2 | 1 | 2 | 2 | 2 | 1 | 2 | 1 |

In the sheets of fifty there are, therefore, exactly 25 varieties of each type, while in the smaller sized sheets there are 21 of type 1 and 19 of type 2.

The 80 centavos.

So far as we can discover there is only one type of this value and it exists in both the fifty and forty sized sheets.

The 1 peso.

This value also exists in but one type and we have only found it printed in sheets of fifty.

Paper.

All the stamps of this issue were printed on ordinary white wove paper as in the case of the earlier series of the same type.

Perforation.

The two sorts of perforation—12 all round, and 16 by 12—are also found in connection with all six denominations of this set.

Imperforate varieties.

All six values are found entirely imperforate. Sheets of the 5c from both settings are known in this condition; the 10c imperforate is known in both fifty and forty stamp sheets; an entire sheet of the fifty printing is known of the 20c and we have blocks showing sheets of the smaller size which must also have existed imperforate; entire sheets of both fifty and forty stamps are known of the 40c; no imperforate sheet of the 80c seems to be known but we have seen a block which undoubtedly came from the forty sized sheet; and the 1 peso is known in an entire sheet of fifty imperforate.

Proofs of the 1882-3-4-5 issues.

We have seen a number of proofs of these issues and as they were evidently all printed at the same time it is best to describe them together rather than in connection with the separate issues. These proofs are found in purple, brown, carmine, blue, green, and yellow, some of these colors occasionally varying in tint. Though we have not seen all values of each issue in every one of these six colors we are positive they exist or did exist from the manner in which the proofs were printed. In our experience the proofs in blue and yellow are the scarcest.

Though absolute proof is at present lacking we are fairly confident that the proofs of all values and dates were printed from one special proof stone. We possess or have seen a number of strips and blocks, in various colors, from the left hand side of a sheet showing that the denominations were printed in the order 10c, 40c, 80c, 1 peso, 20c, and 5c in each vertical row, while the stamps in the first of these rows were dated 1885, those in the next row 1884, and those of the third row 1883. In addition we have pairs or blocks of four showing the same vertical arrangement of values, but with the same dates (1882 or 1883) side by side. For example we have a block of four in red all dated 1883, the two top stamps being of the value 10c and the two lower ones 40c. A comparison of the left hand stamp of the pair of 40c shows it corresponds exactly with the 40c stamp of the same date in the third vertical row of the larger blocks already referred to, thus proving that the fourth vertical row of the proof sheet, like the third, was dated 1883. Then, as we have pairs of different denominations dated 1882 and we have found 1882 and 1883 in combination, we are of the opinion that the complete proof sheet consisted of six vertical rows of six stamps each the stamps in the two last rows all being dated 1882. None of the values of 1884 or 1885 are known in horizontal pairs but only those of 1882 and 1883, which fact gives additional strength to our theory. If our surmise is correct, therefore, the sheet arrangement of these proofs was as follows:—

| Dated | Dated | Dated | Dated | Dated | Dated |
|--------|--------|--------|--------|--------|--------|
| 1885 | 1884 | 1883 | 1883 | 1882 | 1882 |
| 10c | 10c | 10c | 10c | 10c | 10c |
| 40c | 40c | 40c | 40c | 40c | 40c |
| 80c | 80c | 80c | 80c | 80c | 80c |
| 1 peso | 1 peso | 1 peso | 1 peso | 1 peso | 1 peso |
| 20c | 20c | 20c | 20c | 20c | 20c |
| 5c | 5c | 5c | 5c | 5c | 5c |

These proofs are generally found on a distinctly toned paper.

Essays.

We know of no essays of the stamps of the issues of 1882-3-4 and 5.

(To be continued.)

BULGARIA.

BY C. A. HOWES.

(Continued from page 262.)

At last in October 1, 1901, (Old Style) the long-heralded new issue with the portrait of Prince Ferdinand made its appearance. The stamps form a handsome and striking set, all being printed in two colors, the portrait medallion being kept in dark shades of blue, green or brown and in black. They were manufactured in Petrograd (St. Petersburg), it is said, by the Cartographic Bureau of the Russian War Department. They appear to be typographed and come in sheets of 100, divided into four panes of 25 stamps each—five by five. The paper is a somewhat thin white wove and the perforation is $12\frac{1}{2}$ done by a comb machine. The gum is very thin, transparent, smooth and shiny.

This issue remained in use for some ten years and doubtless quite a number of printings were made of some values. This is evident from the variations in shade which are found in numerous cases. As nearly as may be the following list gives the colors of the stamps as first issued, taken from a set received soon afterward. The color of the frame is given first. The figures appended are supposed to have been the supply of each value for the first order; the figures for subsequent orders, unfortunately, do not seem to be available.

October 1, 1901. Perforated $12\frac{1}{2}$.

| | | |
|----|------------------------------------|------------|
| 1 | stotinka, violet & slate | 30,000,000 |
| 2 | stotinki, slate green & blue black | 5,500,000 |
| 3 | “ orange & black | 5,000,000 |
| 5 | “ emerald green & dark brown | 15,000,000 |
| 10 | “ rose red & black brown | 5,400,000 |
| 15 | “ red lilac & slate | 15,000,000 |
| 25 | “ blue & black | 5,000,000 |
| 30 | “ bistre brown & slate | 2,500,000 |
| 50 | “ deep blue & dark brown | 1,000,000 |
| 1 | lev', salmon red & dark green | 500,000 |
| 2 | leva, carmine & black | 50,000 |
| 3 | “ gray & red brown | 50,000 |

In July, 1902, a notice went the rounds of the chronicles in various stamp papers that the frame of the 2 leva had been changed in color from “red to deep carmine in order to avoid confusion with the 1 lev’”. As the two values were not at all similar in shade in the first place, according to the unimpeachable testimony of the early set spoken of above, which is still in the writer's possession, it has always seemed evident that there was a mistake somewhere in this statement. The 2 leva stamp in my collection left Bulgaria in January, 1902, but three months after the set was issued, and is in the usual carmine color! As Bulgaria's use of her high values is not very great, as is shown by the previous sets, there is no doubt that this carmine stamp was of course one of the first order of 50,000. Nor is there much more doubt that the 2 leva stamps in use in June, 1902, were all of the same first order, as otherwise a use of 75,000 or more per year would be indicated, which is not borne out by facts at all. The result of this reasoning would seem to show that the stamp “similar in color to the 1 lev’” and the “deep carmine” stamp were both in the first order of 50,000 and that indications point to the carmine stamp (it is hardly a deep carmine) as having been the first issued and original color.

Where, then, does this leave the 2 leva catalogued as “red and black”? Answer—just where one would expect to find it: an error printed in the color of the 1 lev’. That this must be so, seems evident from these facts: the 2 leva was first issued in carmine and that continued to be its proper color for ten years; the “error” came in the first order of this value and

was issued with the regular color; the color of the "error" is identical with deeper shades of the 1 lev', the normal color of the latter being a salmon red and the color of the 2 leva "error" being a little deeper—in fact, almost a brown-orange; the "error" is a very scarce stamp, apparently much more so than its catalog price would indicate. And, lastly, the fact that the stamp was first chronicled as "red" or "scarlet" and the 1 lev' as "vermillion", "salmon" and "pale red", shows that the two were not so near alike in color as to be confused, and that the 2 leva was at first a red, as is my stamp, though nearer carmine than scarlet. The proper listing of the stamp would therefore, seem to be:—

1902 Perforated 12½

Error, frame in shade of 1 lev', 2 leva brown orange and black.

Another variety in this issue was noted in 1907, when it was found that the 1 lev' was being supplied with the figures "1" in the upper corners that belonged to the 1 stotinka previously issued. The peculiarity of the original "1's" on the 1 lev' was that they had a little horizontal line or serif at the right of the top of the figure; the 1 stotinka had the usual style with sloping "serif" at the left only, and this plate was evidently used for the 1 lev', probably by mistake as the variety seems not to be as common as three year's use would make it, if it had been employed continuously from the time of its discovery to the close of the issue.

1907 Perforated 12½.

Variety, figures of 1 stotinka
1 lev', salmon-red and dark green.

Having begun, Bulgaria found it hard to cease commemorating, so in 1902, at the celebration of the twenty-fifth anniversary of the battle of Shipka Pass, another modest set of three values appeared, but the modesty of numbers was made up for in size and bizarre appearance. On this vignette of crude design are seen the Bulgarians hurling down rocks upon the Turks. The picture is well calculated to give an idea of the fierceness of the struggle which a small nation had to sustain in revolting against the abominable Turkish rule. The fight at Shipka was only one incident in the war which troubled the Balkans from 1876 to 1878 and which ended in the treaty of San Stefano, the first step in the political partition of Turkey.

The war was brought on by the frightful Turkish massacres in Bulgaria, which led Russia to take up the cause of her co-religionists in the Balkans in April 1877. The Turks had only 186,000 men in Bulgaria and 1,000 in Bosnia and Herzegovina, but they were under the orders of a very able general, Osman Pasha. The Russians numbered 750,000 men commanded by Grand Duke Nicholas and re-enforced by 60,000 Rumanians. It was at Plevna that the issue between the two armies was decided. To raise the Russian siege of the city, the Turks had to get through the Shipka Pass; but here they met a valiant little troupe that heroically defended the defile. It was composed of only one Russian regiment and five battalions of Bulgarian volunteers. For five days (Aug. 21st to 25th) Gen. Gurko, assailed by Sulleman Pasha, succeeded in repulsing his attacks. The two adversaries exhausted every means of fighting. While the Turkish soldiers filled up the trenches with their dead in order to cross for assault, the defenders crushed them with fragments of rocks from above. The Turks could not get through. On August 31st Osman Pasha abandoned Plevna; on November 10th he surrendered. At Turkey's request hostilities ceased and negotiations ended in the treaty of San Stefano, which was later revised by the Congress of Berlin.

Speaking only of Bulgaria, the war resulted in making it an autonomous Principality, tributary to the Sultan; while Eastern Rumelia, which seven years later joined itself without serious opposition to Bulgaria, was made a separate Province under a Christian governor. The heroic defense of Shipka had thus indirectly permitted the erection of a new Christian state in Turkey, and we may readily allow the Bulgarians to feel that its importance was worthy of proper celebration.

Around the frame of the stamps we find the names and dates of three important battles in the Turko-Russian war. At the top, naturally, is SHIP-

KA 11 AUGUST"; at the left STARA-ZAGORA 31 YULII (July); and at the right SHEINOVO 29 DEKEMVRII. At the bottom is B'LGARIA and in the upper corners the commemorative dates 1877 and 1902. The stamps were lithographed in Budapest, according to report, in sheets of 100, ten rows of ten, on unwatermarked paper. They were perforated $11\frac{1}{2}$ by guillotine machines. Mr. Poole finds two varieties of each stamp, but the differences are very slight.

The stamps were issued on September 13, 1902, the day of the arrival of the Russian officers who were to be present as guests during the manouevres at Shipka Pass in commemoration of the battle. They were valid for postage not only in Bulgaria but to Russia and Serbia, but were not supposed to be used otherwise in the Postal Union mails. It was stated somewhat indefinitely, that 300,000 or 400,000 of each value were issued.

September 13, 1902. Perforated $11\frac{1}{2}$.

| | |
|----|--------------------|
| 5 | stotinki, rose-red |
| 10 | " blue-green |
| 15 | " blue |

A sudden shortage of 10 stotinki stamps evidently took place in October, 1903, for the 15 stotinki stamps of the regular issue were surcharged with a large "10" at the bottom in black. The surcharge occurs inverted, doubly printed and in a pair with one stamp lacking the surcharge. In the case of the double print the second impression is found in the right upper corner of the stamp. The 10 stotinki stamp also occurs with the surcharge "10" as it is said "one or two sheets were inadvertently (?) mixed with the sheets of 15 stotinki."

October 1903. Perforated $12\frac{1}{2}$.

Surcharged in black.

"10" on 15 stotinki, red-lilac and slate

Varieties—

Inverted surcharge

Double surcharge

Pair, one without surcharge.

Error—

"10" on 10 stotinki, rose-red and black-brown.

After a lapse of five years, another commemorative opportunity presented itself, this occasion being the twentieth anniversary of Prince Ferdinand's accession to the throne of the Principality, which he assumed on August 14, 1887, in succession to Prince Alexander, who had abdicated nearly a year previously. A newspaper paragraph, quoted by Mr. Poole, announced that "The Director of Posts and Telegraphs of Sofia has just been sent by M. Stoyanovich to Budapest, where he is to superintend the manufacture of these stamps, which are likely to be very artistic". Though not as bad as the Shipka Pass "atrocities", they were nevertheless, far from being things of beauty. The main feature of the design is two miniature portraits of Prince Ferdinand, presumably at the dates "1887" and "1907", which are shown above them. Between the vignettes is a winged female figure upholding the Princely Crown. In each lower corner are large plain numerals of value, and arabesques fill in most of the rest of the design. There are no explanatory inscriptions save the two dates, the remainder being the usual B'LGARSKA POSHTSHA and STOTINKI.

The stamps were said to have been produced by a process known as "spitzertype" which is stated to be "an autographic etching process with new grained ground." The description reads very much like the "half-tone" process that we employ so much for magazine illustrations, but the stamps do not possess the "grained" appearance of this process to any extent, and the impression has the flat appearance of a lithograph. There seems to be a wash of very pale color underlying each stamp and extending beyond its frame. They were printed on white unwatermarked paper in sheets of 224, sixteen horizontal rows of fourteen stamps each, which with the large size of the stamps made a huge and ungainly sheet to handle. The perforation is $11\frac{1}{2}$ by a guillotine machine, very likely the one that operated upon the Shipka Pass issue.

It is stated that 500,000 each of the 5 and 10 stotinki were printed and 200,000 of the 25 stotinki. They were issued on Aug. 15th N. S. (August 2nd, O. S.) the anniversary of the accession.

Mr. Poole states that there are two minor varieties of each value, but the differences are very trivial.

- August 15, 1907. Perforated 11½.
- 5 stotinki, dark olive green
 - Variety—imperforate
 - 10 stotinki, reddish brown
 - Varieties—imperforate
 - Vertical pair, imperf. between
 - 25 stotinki, deep blue
 - Varieties—imperforate
 - Imperforate vertically
 - Vertical pair, imperf. between

In connection with the perforation varieties, it is interesting to note the description by "Der Philatelist" of a sheet of the 25 stotinki which had the upper five rows perforated horizontally only, and all the rest of the sheet imperforate.

(To be continued.)

NEW ISSUE NOTES.

We are indebted to Mr. J. B. Leavy for the copy of the circular sent out by the Director of the Universal Postal Union under date of October 23rd, announcing the October distribution, which we print herewith.

- 1st. **United States of America:** Postage stamp of 11 cents;
- 2nd. **Belgium:** Postage stamps of 1 centime, 2, 5, 10, 15, 20, 25, 35, 40, 50 centimes, 1 franc, 2, 5, and 10 francs; Postal cards of 5, 5+5, 10, and 10+10 centimes; Letter cards of 10 and 25 centimes (these values were placed in use on 15 October current and the previous issues retired from circulation on the same date);
- 3rd. **Brazil:** Postage stamps of 50 and 200 reis (these stamps were placed in circulation on May 9th last);
- 4th. **Costa Rica:** Postage due stamps of 2, 4, 8, 10, and 20 centimos of a colon (these values were placed in circulation August 1st last);
- 5th. **French Colonies: Oubangui-Chari-Tchad:** Postage stamps of 1 centime, 2, 4, 5, 10, 20, 25, 30, 35, 40, 45, 50, 75 centimes, 1 franc, 2 and 5 francs, of Middle Congo, bearing in surcharge the mention "Oubangui-Chari-Tchad";
- 6th. **Great Britain:**
 - British Post Offices in Morocco:** Postage stamp of 12 pesetas over 10 shillings;
 - British Guiana:** Postage stamp of 96 cents;
 - Hong-Kong:** Postage stamp of 50 cents;
- 7th. **Nicaragua:** Postage stamp of 6 centavos of a cordoba, bearing in surcharge the mention "Vale—5 cts.—de Cordoba—1915" (this value was placed in circulation August 15th last);
- 8th. **New Zealand:** Postage stamps of ½ penny, 1½ penny, 2, 2½, 3, 4, 4½, 6, 7½, 9 pence and 1 shilling, with the likeness of King George;
- 9th. **Portugal:** Relief postage stamps of 1 centavo and 2 centavos for use in Portugal (including Madeira); of 1 centavo and 2 centavos for use in the Azores (these stamps replace those of which 3 specimens were distributed with circular No. 5281-224 of December 6th, 1912).

NOTES.

Brazil. Current type in new shades. 50 reis gray green, 200 reis bright blue.

Costa Rica. Postage due of new design lithographed by the American Bank Note Co. Rectangle with disc bearing the numeral of value in white, fancy scroll supports at each side of disc, oblong label above bearing the inscription, in three lines, MULTA REPUBLICA DE COSTA RICA, the bottom of the disc cut by a band bearing the word of value, below

a label containing the word CENTIMOS.

| | |
|-------------------|--------------------|
| 2 centimos orange | 8 centimos green |
| 4 centimos blue | 10 centimos violet |
| 20 centimos brown | |

Hong Kong & British Guiana. Colored through.

New Zealand. Profile head of King George in fancy rectangular frame having numerals of value in upper corners, four stars in lower corners, a crown in the middle of the top frame just over head, at bottom Postage & Revenue in small letters over NEW ZEALAND in large capitals. The ½ penny lithographed, other values engraved, watermarked single line N Z over small star.

| | |
|-----------------------|-----------------------|
| ½ penny yellow green | 4 pence deep yellow |
| 1½ pence dark gray | 4½ pence myrtle green |
| 2 pence bright purple | 6 pence bright rose |
| 2½ pence slate blue | 7½ pence red brown |
| 3 pence deep brown | 9 pence pale olive |
| 1 shilling vermilion | |

Portugal. Charity stamps. Large allegorical figure, hooded and draped, enclosing within the drapery held in outstretched arms, the figures of a mother and child, at left, and an old man, at right, all on solid background of color, above REPUBLICA PORTUGUESA, below PARA os POBRES, both in colored letters on white ground, to the left of the large figure on the solid background CORREIO in white letters, to the right of the head of large figure um centavo in white letters in two lines. The other value is the same in all respects except that instead of CORREIO appears the word TELEGRAFOS, and dois centavos for um centavo. 1 centavo dull rose red, 2 centavos dull violet.

BELGIUM. The 1, 2, 5, 10, 15, 20, and 25 centimes cheap typographs, similar in design to the small kings head red cross. Other values large oblong stamps with various fancy framed designs and different central pictures, engraved by Waterlow Co. 35 centimes, town hall at Ipres. 40 centimes, bridge at Dinant. 50 centimes, library at Louvain. 1 franc, harbor at Antwerp. 2 francs, allegorical design, Belgium protecting the Congo. 5 francs, King Albert presenting a flag to his troops from the steps of the town hall at Furnes. 10 francs, central oval with portrait of King Albert, flanked by slightly smaller ovals, the one at left containing portrait of King Leopold I, that at the right portrait of King Leopold II.

| | |
|--------------------------|-----------------------------------|
| 1 centime orange. | 25 centimes dull blue. |
| 2 centimes brown. | 35 centimes orange brown & black. |
| 5 centimes yellow green. | 40 centimes yellow green & black. |
| 10 centimes carmine. | 50 centimes lake & black. |
| 15 centimes purple. | 1 franc violet. |
| 20 centimes red violet. | 2 francs greenish slate. |
| | 5 francs dark slate blue. |
| 10 francs light brown | |

At the present time I can see no reason to classify these stamps other than Charity Stamps.

The National Philatelic War Fund of Great Britain.

Second List of Stamp Donations.

We are now able to announce a second list of fifty donations of stamps for the National Philatelic War Funds Auction which is to be held early in the New Year in aid of the British Red Cross Society and the Order of St. John of Jerusalem. Stamps for the sale should be sent to Mr. L. L. R. Hausburg, Heathside, Weybridge, Surrey.

Appended to the acknowledgments of stamps, we give a first list of the contributions of philatelic literature. All who can send books on stamps, philatelic journals, etc., are requested to send them to Mr. W. Corfield, 27 Longton Grove, Sydenham, S. E.

At an early date it is hoped to issue a first list of cash donations. It is desired to draw the attention of the societies to this section of the Fund. In the case of the smaller societies, where it is difficult to secure gifts of stamps, the members can subscribe in cash, and the sums collected should be forwarded to the Hon. Treasurer, Mr. C. E. McNaughtan, 4 Southampton Row, W. C.

STAMP DONATIONS (Second List).

- B. Pinner. South Australia high values, overprinted "Specimen"; and Sudan Army Official 1 piastre, block of 4.
- Col. S. P. Peile. Four entires of Mexico and Venezuela, and various Fiscals.
- N. H. Chapman. Various modern Siam, etc.
- W. C. Stone. Block of six Natal 2½ d. on 4d.
- F. E. Horton. Two vertical pairs U. S. A. 1855 10c., imperf., mint.
- Ralph Wedmore. Valuable collection of Queensland.
- J. O. B. Saunders. India 1854 4 annas "inverted head," cut to shape; pane of 80 India R1., 1874; various valuable mint Natal, Seychelles, Zanzibar, and British India overprinted for Native States.
- B. W. H. Poole (second donation). 20c Bolivar 1879 green, error of color, and other rare stamps.
- C. E. McNaughtan. 2½ d on 2s Sierra Leone, type F, used.
- Miss E. A. Hurst. Collection started in 1870.
- S. D. Timms. ½ d and 1d "R. H." Official, used.
- C. S. Warbrick (second donation). Pair of 2d Sydney Views, plate I.
- Ross O'Shaughnessy. Various valuable used and unused British Colonial and other stamps.
- A. F. Wiren. Various New Zealand, Australian, etc.
- A. J. France (per W. Bull). Reconstructed sheet of 1d red Great Britain, imperf.; pane of twenty 4½ d; and other British stamps.
- H. P. Ereaud. Block of four Natal Telegraph 1s., imperf.; pair 30c Ceylon 1893, imperf.
- Miss Lucy Dickson. Various.
- Victor G. Loly. Various mint blocks.
- W. Patterson. Various unused and used.
- J. R. M. Albrecht. Four Mulready's, various Registration envelopes, and other entires.
- Miss C. W. Mackintosh. Collection.
- Miss Mary D. Robson. An old collection.
- Nevile Stocken. New Zealand 1d, first type, watermarked N. Z., rouletted; set of Togo, overprinted "Anglo-French Occupation", on entire; and other scarce stamps.
- Miss Lee. Ceylon, mint blocks of fifty 20c green 1884, and forty-nine 3c brown and green, and 50 envelopes.
- Mrs. Keen. Hospital stamps.
- J. W. Hall. Togo, mint "Anglo-French" and "Franco-Anglaise" occupation stamps, in singles and pairs.
- J. R. W. Piggott. A valuable lot of British East Africa, 21 used and unused of the earlier issues, including three of the scarce manuscript varieties, and a stamped envelope.
- J. Jellyman. A valuable lot of mint U. S. A.; and others, used and unused.
- F. C. Henderson. Dominica 1s C. A., mint.
- J. W. Kayton-Schofield. Various used and unused South Africa, Transvaal, and Orange River Colony.
- L. L. R. Hausburg. Reconstructed sheet of Victoria 2s blue on green, 1864; collection of old issues of Victoria; a set of Trinidad surcharged "9d" by the Postmaster on the occasion of the visit of H. R. H. the Duke of York (now H. M. King George V.) to the island, and presented by H. R. H. to the Boer War Fund Auction—only one block of four of each denomination was thus surcharged.
- J. Chamberlain. Set of South Australians, issued to commemorate the opening of the Australian Commonwealth Parliament by H. R. H. the Prince of Wales (now H. M. King George V.).

- Sir C. Stewart-Wilson. Twenty-three proofs of U. S. A. on India paper; mounted on large cards, including the 1894-5 issue; Special Delivery, Postage Dues, and Newspaper Stamps of 1895.
- G. Ginger. Various Labuan, North Borneo, St. Christopher, Jamaica and Tobago, including scarce varieties.
- Mrs. E. Blackman. Various modern stamps.
- Stanley Gibbons, Ltd. A very fine and valuable lot (catalogued at £300) of rare stamps only, including early issues St. Lucia, in mint blocks of four; Cape of Good Hope Triangulars, in singles, mint. Among the used are copies of the blue and green circular British Guianas. Among the foreign stamps are the 10 pen. error of Finland, various tete-beche Egypt, France 20c blue tete-beche, blocks of Venezuela, and some very rare Swiss, including an unused strip of four of the "Poste Locale," the central cross with black frame, and a mint copy of one of the great rarities, the 2½ rappen "Poste Locale," the central cross being without frame.
- Walter Scott, J. P. Cape Triangulars, block of four 1d on blue paper; Victoria "Queen on Throne," pair of the 2d, one being the variety "TVO"; Virgin Islands ½d 1899, block of six containing both errors.
- W. Allan Harmer (second donation). Great Britain 10s cobalt, Queen, I. R. Official, used.
- Miss Walter. Mint set Australian Commonwealth, up to and including 10s. Anon (Oxted). A quantity of envelopes, etc., from the front.
- G. P. D. Versey. Various stamps and entires.
- M. Giwelb. Labuan, sheet of 6c on 8c; Mauritius, half sheet of 2c green; Tasmania, sheet of ½d on 1d, containing varieties; Straits Settlements, 2c on 5c blue (two vertical strips of three).
- Bridger & Kay. Various scarce stamps.
- D. Field. India, pair of 4 annas 1854 red and blue, "Specimen," with red wavy lines; 4 annas 1854, sheet of twelve, one with inverted head; ½ anna 1854, strip of eight types, in blue, with "Specimen" on back; ditto, ½ anna red; Belgium, King Albert, sheets of 300 each of the 5c and 10c.
- E. B. S. Benest. Brazil, a large number of mint blocks and sheets, including entire sheets of the 1899 50r on 20r green, 100r on 50r green, 300r on 200r violet, said to be unique; also two entire sheets of Argentine Republic.
- H. J. Glover. An old collection.
- D. Pattison. Large quantity of used and unused Peru, Chile, and other countries.
- Frank Barker. Modern unused Indian and Convention States.
- "H3." Various Cape Triangular and other stamps, used and unused.
- Captain England. An old collection, also 13 Sydney Views, West Australia 6d., litho, and other old and scarce British Colonials.

LITERATURE DONATIONS (First List).

- B. Gordon Jones. "Indian Convention States" (6) and "Fiscal and Telegraph Stamps of Ceylon" (3), all signed copies.
- W. E. Imeson. "The Stamp Fiend's Raid," and "Illustrated Music Titles."
- W. Allan Harmer. Various volumes "Gibbons' Stamp Weekly," "Ewen's Weekly Stamp News," and "Philatelic Journal of Great Britain."
- Dr. J. N. Keynes. "London Philatelist," 1892-1912 (21 vols.).
- E. J. Reed. Parcel of books and periodicals.
- Gerald Coles. "Africa" (Part III.).
- Fred. J. Melville. "Norges Frimerker 1855-1914," "Stamps of the Steamship Companies," "Our Boys and Girls" (U. S. A.), with stamp department, etc.
- W. J. Ferens. "College Stamps."
- Mrs. A. C. Hine. "British Isles."
- Major S. M. Castle. Delhi Durbar Postal Guide, India (five copies).
- Wilnot Corfield. "Indian Convention States," "Fiscal and Telegraph Stamps of British India," and "More Dak Dicta" (two copies of each work).
- Anon. "New Zealand," "Fiji," and "British Isles."

FRED J. MELVILLE.

REVIEW.

Yvert & Tellier Catalogue, 1916.

This catalogue, better known as Champion's Catalogue, made its appearance as advertised and followed the Scott Catalogue within a week.

The style of the publication is uniform with former issues and the standard of excellence is maintained throughout with reference to the illustrations and printing.

Prices, which are net, are generally high, and if these can be obtained from collectors generally it speaks well for conditions as they are and promises better for the future.

The pricing throughout is also very thorough, and what is most noticeable is that there are very few items, comparatively, which have no price appended.

Catalogue des Timbres-poste.

Published by Yvert & Tellier, Amiens, Belg.

Theodore Champion & Co., Paris, France.

XXXII + 835 + 62 pp. octavo.

Bound in cloth, 4 Fr.

UNITED STATES CONFEDERATES Locals and Carriers

What Have You to Offer?

JOHN A. KLEMANN
118 Nassau St., NEW YORK

WANTED FOR CASH

Bolivar No. 2

Pairs, strips and blocks. Send
at your lowest cash price.

Bolivar, Philatelic Gazette
118 Nassau St., New York

C. G. DIETRICH,

212 Broadway, New York, N. Y.

Member A. P. S., Dresden Philatelic Society, Berlin & Vienna Dealers Association, offers his superb stock of medium and rare stamps of all countries. Moderate Prices—Fine copies only.

SPECIALTIES

British—British Colonials—used and unused.
19th & 20th Century.

—Send Want Lists—

Approval selections sent to responsible Collectors.

Scott's No.

Reunion.

*151 Black Cross Error \$6.00

Togo on Gold Coast.

95-98, 100, used ½, 1, 2, 2½, 6p

Set .75

99 used, 3p, white back 1.25

Samoa—surch. G. R. I.

101 ½p on 3pf 2.00

102 ½p on 5pf 2.00

103 1p on 10pf, fine, used on

piece 4.00

104 2½p on 20pf, fine, used on

piece 2.00

108 6p on 50pf, fine 3.00

New Britain.

* 2 1p on 5pf 2.75

* 3 2p on 10pf 2.50

* 4 2p on 20pf 2.50

* 5 2½p on 10pf 12.50

* 6 2½p on 20pf 12.50

* 7 3p on 25pf 16.50

* 8 3p on 30pf 16.50

* 9 4p on 40pf 12.50

* 10 5p on 50pf 21.00

*201 O. S. 1p on 3pf 2.50

*202 O. S. 1p on 5pf 5.00

201 O. S. 1p on 3pf 2.50

202 O. S. 1p on 5pf 5.00

Marshall Islands—surch. G. R. I.

* 31 1p on 5pf 4.00

* 32 2p on 10pf 1.25

* 33 2p on 20pf 1.25

* 36 4p on 40pf 18.50

Togo—Anglo-French Occupation

* 55 10pf, used or unused 15.00

Togo Occupation, Franco-Anglaise.

83 5pf 12.50

84 10pf 12.50

Colombian Republic.

*566 1910, A. R., 5c .40

Turkey—War Charity.

* Surcharged star and crescent,
10, 20pa, 1 pia. Set .40

Foreign Revenues.

Whether you collect them or not you need a **REVENUE CATALOGUE**. Very often a revenue stamp worth dollars is thrown away or exchanged for a few cents. **Forbin's Revenue Catalogue** is the only catalogue giving illustrations, descriptions and prices of the revenue stamps of all countries. Price **\$1.50**. Dealers supplied.

VAHAN MOZIAN,
140 Nassau St., New York City.

DO YOU RECEIVE OUR MONTHLY BULLETIN?

Samples free, or for 12 cents (to cover cost of postage) it will be mailed for one year. Volume II (just concluded) consisted of 128 pages of news items and special offerings.

November Issue Contains
Large list of War Issues
Large offerings of U. S. Plate Number Strips
U. S. Blocks and Complete Sheets
Complete list current Revenues on both papers.

Don't Miss It.

ECONOMIST STAMP CO.
87 Nassau St. New York City

NE PLUS ULTRA.



Made in America

Interchangeable Leaves

BLANK ALBUMS - \$4.00 and up
STOCK BOOKS - \$2.00 and up

Used by the foremost Collectors and Dealers
Complete price list free on request



"Ne Plus Ultra" Watermark Revealer
Price 50c. Postage 10c. extra

All "Ne Plus Ultra" supplies manufactured exclusively by
SCOTT STAMP & COIN CO.
127 Madison Ave. New York City

PREPAREDNESS

is a much discussed subject. We have not only believed in it but practiced it in the past. The result is that we are prepared to meet the demands of out of town collectors in a surprising way. Our finest stock is kept in such shape that it can be submitted on approval at a moment's notice. Our much admired

PINK LIST

fully describing over 100 different selections of **U. S.** and **300 Foreign** is a revelation to many a collector.

Fine, clean stamps free from surplus hinges, neatly mounted. Reasonable prices.

Write for the above list or a
Specialized Selection

of your favorite country.

The above books are frequently remade and much new stock added.

—

J. M. BARTELS CO.

99 Nassau Street,

New York, N. Y.

Up & index

1915
Vol. V

JANUARY, 1915

No. 1

THE PHILATELIC GAZETTE

v. 5
1915

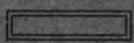

| | Page |
|---|------|
| The United States Government Collection of Postage Stamps | 1 |
| The Postal Issues of Austria | 5 |
| New Plate Numbers | 11 |
| A Detailed History of the General Issues of United States Postage Stamps from 1847 to 1890 | 13 |
| Editorial | 14 |
| Short Notes and News | 15 |
| New Issues | 17 |

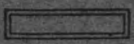

NASSAU STAMP COMPANY
118 Nassau Street
NEW YORK

NASSAU STAMP CO.

MEXICO:—Our sales books have been remounted with many important additions—If you collect this country, it will pay you to look them over.

HAYTI:—We can supply all the issues from A to Gl. O. Z., including varieties. *Send us your list.*

UNITED STATES:—The largest stock in America. *We make a specialty of filling WANT LISTS.* If you have had difficulty in the past, send your list to us and be convinced how pleasant it is to get what you want, when you want it.

NEW ISSUES:—We hold a good stock of 20th Century Stamps including most of the rare ones.

SPECIAL OFFER:—*Portuguese Colonies.* Last lot of 108 surcharges, mint -----\$11.75

Belgian Congo—Both surcharges, printed and hand-stamped; send us your list of wants.

Mexico.—Victoria de Torreon—very rare. Scotts numbers 355 to 360 inclusive.

| | | | |
|-----------------|--------|------------------|------|
| 1c deep blue | \$5.00 | 5c gray green | 1.50 |
| 2c yellow green | 5.00 | 10c red | 5.00 |
| 4c blue violet | 5.00 | 20c yellow brown | 5.00 |

U. S. 1908, 1c green, complete sheet of sixty stamps issued by the Department to use up sheets from which the central eight rows had been taken for stamp affixing machines—very rare -----\$10.00

We will send anything we have on approval against first class commercial references.

118 Nassau St., New York, N. Y.

89th SALE

JANUARY 26th, 1915

Original Covers—Mr James R. White
Hawaii—Mr. W. Herbert Dole

90th SALE

FEBRUARY 2, 1915

Balance of Collection—Mr. J. R. White
20th Century—Mr. Andres Barral
Catalogue mailed on request.

J. C. Morgenthau & Co.

87 Nassau St., New York City.

Volume IV. of
THE COLLECTORS' JOURNAL
(of Chicago)

with index, unbound, 75c. Bound, \$1.50. Volume V. began with the August issue. Have you seen it? Several improvements in the new volume together with added features, places this publication in the lead of Philatelic Magazines, and if you do not receive it regularly YOU ARE THE LOSER.

By subscription, 50c. Sample copy 5c
Send 15c for a bunch of back numbers.

H. L. LINDQUIST, Editor,

700 E. 40th St., Chicago.

U. S. BIGGEST PHILATELIC PAPER

Send 10c. for three months, 300 pages, the oldest, largest and best collectors' monthly for all kinds of Hobbies—Coins, Stamps, Weapons, Old Pistols, Curios, Relics, Old Books, Minerals, Sciences, Post Cards, Rarities and New Finds for all kinds of Collectors. Over 12,000 ads past 2 yrs.

The Philatelic West, Superior, Nebr., U. S. A.

75c. entitles you to a year's subscription and a free 20-word exchange notice in the largest exchange department extant. Or send \$1.25 for Lincoln fine English catalog. Has U. S. stamps illustrated and include the West for 1 year.

This **Illustrated 100 Page Monthly** was established in 1895, and has the largest circulation of any collectors monthly in the world, and in size has no rival. More ads, in the West than any two other American Philatelic monthlies combined. The best paying medium for advertisers. Rates small, results large. 3 cents per word; 3 times at price of 2. Sample copy free. Try 6 months and see.

Locals and Carriers

What have you to offer?

Send at your lowest cash price.

JOHN A. KLEMANN

118 Nassau St. New York

THE NEW ENGLAND PHILATELIST

Edited by Russell L. Stultz

Mr. Collector!

Are you aware that you can get more real news of what is going on in the stamp world in **The New England Philatelist** than you can in any two other philatelic publications? Send for a sample copy and see for yourself. **The New England Philatelist** has been termed the newspaper of philately and truly it is. The most complete report of the S. P. A. Convention will be found in its October issue. Send for a sample copy.

Subscription 50c per year.

THE ESSEX PUBLISHING CO.

Box 115a

LYNN, MASS.

United States Specials

| | | |
|---|-------|--------|
| 1847, 5c, two copies on cover | | \$3.50 |
| 5c, vertical pair on cover | | 5.00 |
| 10c, on cover | | 5.00 |
| 1851, 1c type II and IV in pair | | 4.00 |
| 1857, 5c brown type I, vertical strip of three | | 7.50 |
| 10c type II pair, dated town cancellation | | 2.50 |
| 10c type II strip of three | | 4.00 |
| 1861, 12c pair | | 1.25 |
| 1909, 2c Lincoln, mint imperforate center block | | 1.00 |

Collection of low priced stamps nearly complete up to \$5 catalogue value in United States album, ready to send on approval. Every stamp in superb condition. Reference please.

New Arrivals—All Mint:

| | | |
|---|-------|-----|
| German Morocco 1905, 5c on 5p of 1900 issue by error (Scotts No. 721a \$1.50) | | .50 |
|---|-------|-----|

War stamps issued to assist widows and orphans:

| | | |
|--|-------|-----|
| Austria 7h and 12h | | .12 |
| Bosnia 7h and 12h surcharged on 1906 issue | | .14 |
| Hungary 7f and 12f surcharged on Flood issue | | .16 |

EUGENE KLEIN

142 So. 15th Street

Philadelphia, Pa.

BROWN'S BULLETIN —OF— 20th CENTURY

The following 50 items are random selections from my regular counter books. They are not special advertised prices but my regular every day prices. I have one NET price on all my stamps. The fact that it is on your want list or not, does not affect my price! Think this over!

| | |
|---|--------|
| Australian Commonwealth, 1902, 5sh | \$2.40 |
| " " " 10sh | 8.50 |
| Austrian Levant, 30pi green | 1.60 |
| Azores, 1910, 50 rose, error | 4.50 |
| Barbados 2sh6d, CA | 1.40 |
| Br. Central Africa 6d CAC | 3.25 |
| Br. Guiana 1905, 96c | 1.40 |
| Br. Honduras, \$5.00 George | 6.10 |
| Cayman, 1sh, brown CAC | 1.40 |
| Chile, 1910, 5 peso | 2.20 |
| China, 1913 Republic, complete | 8.70 |
| China, 1914 Dues, complete | .60 |
| Dahomey, 1914 complete to 5F | 3.33 |
| Fiji, 1903, 5sh CA | 1.90 |
| Gambia, "one Penny" on 3sh | 2.70 |
| German China, 2½ Dollar | 1.75 |
| Hong Kong, 1902, 12c blue | .90 |
| " " 1911, \$2.00, red center | 2.00 |
| India, "George" 1R service | .60 |
| Kiaochu, 2½ Dollar | 1.55 |
| Labuan \$1.00 crown | 2.10 |
| Lagos, 5sh CAC | 1.90 |
| Luxemburg, page complete, 2 sets | 6.80 |
| Mauritius, George 25c yellow | .20 |
| Montserrat, 2sh6d CA | 1.60 |
| " " 5sh 1910, Edward | 1.90 |
| Netherland, Jubilee, 1910, 10G. (list \$12.00) | 8.50 |
| North Borneo, 1909, 18c, scarce | .80 |
| Papua, 2sh6d rose (1910) | .80 |
| Portuguese Colonies, have practically all Republica "Vasco" and new design sets complete. | |
| Portuguese Congo, 500 and 700, 1901 | 2.10 |
| Rhodesia, 1909 or 11 10 3sh | .95 |
| Roumania, 1903 5L violet | 1.60 |
| Russia, 1913 "Romanof" complete | 11.45 |
| " " China, 1907, 10R | 6.70 |
| " " Trebizonde, set of 6 | 1.00 |
| St. Vincent, 1906 5sh on yellow | 2.10 |
| Spain, 1910, 10p yellow | 2.70 |
| Straits, 1902, \$1.00 CA | 2.10 |
| " " \$2.00 CAC | 2.60 |

No matter what stamp you may want in the 20th Century—you should write me. I do not sell stamps for less than I think they are worth but sell them at what I think.

Fair, Honest Prices.

FRANK P. BROWN CO.

325 Washington St., Boston, Mass.

My Enthusiasm

runs along the line of philatelic journalism. It has found

Expression

for over 4 years in the publication of

'Everybody's Philatelist'

Not for gain—mere money. No. No. I'm hammering at the permanent up-building of philately and its development in new fields, and I've been told that I've accomplished something tangible along these lines.

Are you interested?

28 page monthly, 50 cents a year.

John M. Holt, M. D.

U.S. Marine Hospital San Francisco, Cal.

GAMBIA (Unused o. g.)

These beautiful stamps are from a specialized collection and every copy selected with reference to its superior condition. This is a rare opportunity for lovers of this country to get the best there is.

| | Price | | Price |
|----------------|--------|----------------|--------|
| 1886 No. 12 ¼p | \$.04 | 1898 No. 20 1p | \$.06 |
| " 13 1p | .10 | " 21 1p | .10 |
| " 14 2p | .12 | " 22 2p | .12 |
| " 14A 2p | .18 | " 23 2½p | .15 |
| " 15 2½p | .12 | " 24 3p | .45 |
| " 15A 2½p | .15 | " 25 4p | .45 |
| " 16 3p | .18 | " 26 6p | .50 |
| " 17 4p | .22 | " 27 1sh | 1.00 |
| " 18 6p | .30 | | |
| " 19 1sh | .45 | | |

1886 set complete as above ¼p to 1sh (including 14A and 15A) 10 var. \$1.75.

1898 set complete as above ½p to 1sh 8 varieties, \$2.75.

Can supply blocks of four at four times price of each of Nos. 12, 13, 14, 15, 16, 17.



Would be pleased to send a selection of the above and many of the earlier issues of which we have a limited supply. Orders for less than 50c must include return postage.

CLARKE STAMP CO.
Round Lake, Illinois

THE PHILATELIC GAZETTE



| | Page |
|---|------|
| The United States Government Collection of Postage Stamps | 21 |
| The Kansas City Roulette | 25 |
| The Postal Issues of Austria | 26 |
| A Detailed History of the Several Issues of the United States Postage Stamps from 1847 to 1890 | 30 |
| New Issue Notes | 31 |
| United States | 32 |
| The U. S. Experimental Papers with 3 mm. Spacing | 33 |
| Editorial | 34 |
| Short Notes and News | 35 |
| The 1 cent Green, 1910, in Sheets of Sixty | 36 |
| Communications | 37 |
| Society Notes | 38 |
| Auction Report | 38 |

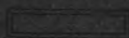

NASSAU STAMP COMPANY
118 Nassau Street
NEW YORK

NASSAU STAMP CO.

U. S. PERF. 10—We can supply all values including the \$1.00 and Special at 10% over face.

HAYTI:—We can supply all the issues from A to Gl. O. Z., including varieties. *Send us your list.*

UNITED STATES:—The largest stock in America. *We make a specialty of filling WANT LISTS.* If you have had difficulty in the past, send your list to us and be convinced how pleasant it is to get what you want, when you want it.

NEW ISSUES:—We hold a good stock of 20th Century Stamps including most of the rare ones.

SPECIAL OFFER:—*Portuguese Colonies.* Last lot of 108 surcharges, mint \$11.75

Belgian Congo—Both surcharges, printed and hand-stamped; send us your list of wants.

Mexico.—Victoria de Torreon—very rare. Scotts numbers 355 to 360 inclusive.

| | | | |
|-----------------|--------|------------------|------|
| 1c deep blue | \$5.00 | 5c gray green | 1.50 |
| 2c yellow green | 5.00 | 10c red | 5.00 |
| 4c blue violet | 5.00 | 20c yellow brown | 5.00 |

U. S. 1908, 1c green, complete sheet of sixty stamps issued by the Department to use up sheets from which the central eight rows had been taken for stamp affixing machines—very rare \$10.00

We will send anything we have on approval against first class commercial references.

118 Nassau St., New York, N. Y.

THE PHILATELIC GAZETTE



| | Page |
|--|------|
| The United States Government Collection of Postage Stamps..... | 41 |
| United States | 46 |
| New Issue Notes | 47 |
| Bolivar | 49 |
| The Kansas City Roulettes | 51 |
| United States—1851 Issue | 53 |
| Editorial | 54 |
| Garfield-Perry Stamp Club | 55 |
| Washington Notes | 58 |
| Falsification of the Stamps of 20 Pesos, Green, Issue 1891 of the Argentine Republic | 60 |
| Auction Reports | 61 |
| Society Notes | 63 |
| Review | 66 |



NASSAU STAMP COMPANY
118 Nassau Street
NEW YORK

NASSAU STAMP CO.

U. S. PERF. 10—We can supply all values including the \$1.00 and Special ----- at 10% over face.

HAYTI:—We can supply all the issues from A to Gl. O. Z., including varieties. *Send us your list.*

UNITED STATES:—The largest stock in America. *We make a specialty of filling WANT LISTS.* If you have had difficulty in the past, send your list to us and be convinced how pleasant it is to get what you want, when you want it.

NEW ISSUES:—We hold a good stock of 20th Century Stamps including most of the rare ones.

SPECIAL OFFER:—*Portuguese Colonies.* Last lot of 108 surcharges, mint ----- \$11.75

Mexico.—Victoria de Torreon—very rare. Scotts numbers 355 to 360 inclusive.

| | | | |
|-----------------|--------|------------------|------|
| 1c deep blue | \$5.00 | 5c gray green | 1.50 |
| 2c yellow green | 5.00 | 10c red | 5.00 |
| 4c blue violet | 5.00 | 20c yellow brown | 5.00 |

U. S. 1908, 1c green, complete sheet of sixty stamps issued by the Department to use up sheets from which the central eight rows had been taken for stamp affixing machines—very rare ----- \$10.00

We will send anything we have on approval against first class commercial references.

118 Nassau St., New York, N. Y.

THE PHILATELIC GAZETTE



| | Page |
|---|------|
| United States Government Collection of Postage Stamps | 69 |
| New South Wales Two Pence Laureate, Plate II of 1853 | 72 |
| A Detailed History of the General Issues of United States Postage Stamps from 1847 to 1890 | 73 |
| The Postal Issues of Austria | 75 |
| New Issue Notes | 79 |
| New Plate Numbers | 80 |
| Chronicle of U. S. Envelopes | 81 |
| Editorial | 82 |
| United States Local Stamps | 84 |
| Auction Report | 86 |
| Society Notes | 87 |
| Communications | 89 |
| Review | 90 |



NASSAU STAMP COMPANY
 118 Nassau Street
 NEW YORK

NASSAU STAMP CO.

We have just purchased the

United States Collection of Mr. C.E.Chapman

which was awarded

Gold Medal, Class B, Section I

Gold Medal, Class B, Section II

New York Exhibition, 1913.

We now have it priced ready for sale and would like to hear from collectors who would be interested.

WANT LISTS. We make a specialty of filling them. If you have had difficulty in the past send yours and be convinced how pleasant it is to get what you want when you want it. If you have never done business with us, send us first-class commercial references, and we will send you anything we have, on approval.

UNITED STATES. We have the largest stock in America.

NEW ISSUES. We hold a good stock of 20th century stamps including most of the rare ones.

SPECIAL OFFER

Portuguese Colonies—last lot of 108 surcharges, due in a few days, \$11.75.

118 Nassau St., New York, N. Y.

THE PHILATELIC GAZETTE



| | Page |
|---|------|
| Special Printing of Die Proofs for the San Francisco Exposition | 117 |
| The Postal Issues of Austria | 125 |
| New Issue Notes | 128 |
| United States Local Stamps | 131 |
| New South Wales | 132 |
| Historical Discovery of the Date of Issue of United States Stamped Envelopes | 132 |
| Check List of U. S. Stamp Books | 136 |
| U. S. Envelopes 1911-15, 1c Die C, 2c Die D | 137 |
| Editorial | 138 |
| The Hobby of Stamp Collecting | 139 |
| Bolivar | 140 |
| A Detailed History of the General Issues of United States Postage Stamps from 1847 to 1890 | 143 |
| Short Notes and News | 145 |
| Auction Report | 148 |
| Society Notes | 149 |



NASSAU STAMP COMPANY
118 Nassau Street
NEW YORK

NASSAU STAMP CO.

We have just purchased the

United States Collection of Mr. C.E. Chapman

which was awarded

Gold Medal, Class B, Section I

Gold Medal, Class B, Section II

New York Exhibition, 1913.

We now have it priced ready for sale and would like to hear from collectors who would be interested.

WANT LISTS. We make a specialty of filling them. If you have had difficulty in the past send yours and be convinced how pleasant it is to get what you want when you want it. If you have never done business with us, send us first-class commercial references, and we will send you anything we have, on approval.

UNITED STATES. We have the largest stock in America.

NEW ISSUES. We hold a good stock of 20th century stamps including most of the rare ones.

SPECIAL OFFER

Portuguese Colonies—last lot of 108 surcharges, \$11.75.

Canal Zone—1915—Pictorial
Panama—1915—Pictorial
U. S.—10 perfs. } 15% over face.

118 Nassau St., New York, N. Y.

THE PHILATELIC GAZETTE



| | Page |
|---|------|
| The United States Government Collection of Postage Stamps | 205 |
| The Postal Issues of Austria | 209 |
| Bolivar—The Stamps of 1879-1899 | 213 |
| Editorial | 216 |
| Short Notes | 217 |
| The Universal Postal Union | 217 |
| Washington Notes | 221 |
| New Plate Numbers | 222 |
| Chronicle of U. S. Envelopes | 223 |
| New Issue Notes..... | 223 |
| British North Borneo | 224 |
| Society Notes | 225 |

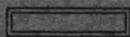

NASSAU STAMP COMPANY
118 Nassau Street
NEW YORK

NASSAU STAMP CO.

THE HENRY J. CROCKER COLLECTION United States

and fourteen (14) other countries have been added to our purchase of

THE CHAPMAN COLLECTION Unparalleled opportunity to complete.

SEND YOUR WANTS.

Prompt reply insures early choice.

WANT LISTS. We make a specialty of filling them. If you have had difficulty in the past send yours and be convinced how pleasant it is to get what you want when you want it. If you have never done business with us, send us first-class commercial references, and we will send you anything we have, on approval.

UNITED STATES. We have the largest stock in America.

Special—1847—5c, good copies, while they last...\$1.00

NEW ISSUES. We hold a good stock of 20th century stamps including most of the rare ones.

SPECIAL OFFER

Portuguese Colonies—last lot of 108 surcharges, \$11.75.

New lot of 20 surcharges, \$9.60

Canal Zone—1915—Pictorial
Panama—1915—Pictorial
U. S.—10 perfs. } 15% over face.

118 Nassau St., New York, N. Y.

THE PHILATELIC GAZETTE



| | Page |
|---|------|
| The United States Government Collection of Postage Stamps | 257 |
| Bulgaria | 261 |
| Chronicle of U. S. Envelopes | 263 |
| The Postal Issues of Austria | 263 |
| Belgium: Line-Engraved Stamps | 266 |
| Notes on Die Proofs of the United States and Colonies | 269 |
| New Plate Numbers | 269 |
| Editorial | 270 |
| Short Notes and News | 271 |
| The Confederate States of America | 272 |
| Cancellations—The Wesson Device | 275 |
| Auction Report | 278 |
| New Issue Notes | 279 |
| The National Philatelic War Fund of Great Britain | 281 |
| Review | 288 |



NASSAU STAMP COMPANY
118 Nassau Street
NEW YORK

THE NASSAU STAMP CO.

begs to announce

the purchase

of

The Celebrated

CRAWFORD COLLECTION

of

UNITED STATES ISSUES

including

Postmasters, Carriers,

Proofs and Essays.

NASSAU STAMP CO.

118 Nassau St.

New York, N. Y.

THE PHILATELIC GAZETTE



| | Page |
|---|------|
| The United States Government Collection of Postage Stamps | 285 |
| The Confederate States of America | 289 |
| Belgium: Line-Engraved Stamps | 293 |
| United States Local Stamps | 296 |
| Editorial | 298 |
| Short Notes | 299 |
| Envelope Chronicle | 299 |
| Bolivar—The Stamps of 1879-1899 | 300 |
| Bulgaria | 304 |
| New Issue Notes | 307 |
| The National Philatelic War Fund of Great Britain | 308 |
| Review | 311 |

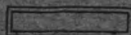

NASSAU STAMP COMPANY
118 Nassau Street
NEW YORK

THE NASSAU STAMP CO.

Purchased in 1915

THE UNITED STATES COLLECTIONS

OF

Mr. Clarence E. Chapman

Mr. Henry J. Crocker

The Earl of Crawford

Finest and largest stock of these issues in
the world.

Want lists filed and filled in the order of
their receipt.

JOHN A. KLEMANN, Pres.

118 Nassau St.,

New York, N. Y.

FOR 6 MARKS AND POSTAGE I WILL SEND

161 good stamps cataloguing M147.30, Sent 1915 Catalog.

The lot includes 50 English and French Colonials, several Roumanian, Ajutor and Silistrian stamps; complete sets of Europe, also one each, Balkan, Cuba on U. S., Hungarian and Canadian War Stamps, Belgium (Albert), China (Revolution), Chile, Swiss provisional, Azores, including Republica, new Austrian dues, Liberia, (complete set) &c &c.

Alfred Kurth—Colditz in Sachsen, Germany.

A new Swiss 3fr or 5fr with every 3 packages.

Biggest Philatelic Paper

Send 10c for four months, 400 pages, the oldest, largest and best collectors' monthly for all kinds of Hobbies—Coins, Stamps, Weapons, Curios, Relics, Old Books, Minerals, Sciences, Illustrated Souvenir Post Cards, Rarities and New Finds for all kinds of collectors. Over 11,000 ads. past two years.

The Philatelic West Superior, Neb.

U. S. A.

75c entitles you to a year's subscription and a free 20-word exchange notice in the largest exchange department extant.

This illustrated 100-Page Monthly was established in 1895, and has the largest circulation of any collectors' monthly in the world, and in size has no rival. More ads. in the

WEST

than in all other American Philatelic monthlies combined. The best paying medium for advertisers. Rates small, results large. 3 cents per word; 3 times at price of 2. Sample Copy Free.

BOUND VOLUMES

of

The Philatelic Gazette

- Vol. I\$3.00 net
- Vol. II 2.50 "
- Vol. III 2.50 "
- Vol. IV 2.00 "

NASSAU STAMP CO.

118 Nassau St., New York, N.Y.

If you are not a subscriber or have not seen a recent sample copy of

EVERYBODY'S PHILATELIST

You have missed something of the philatelic

Joy of Living

and have not had all "what's coming to you." We aim to be a constructive force in upbuilding philately.

4 mos. trial 10c; A year 50c; Three years \$1.00; Life subscription, \$5.00.

Ad rates 75c per inch on contract. No false claims. No exaggeration about circulation.

DR. HOLT,

Marine Hospital, San Francisco, Cal.

United States Stamps

are featured in the authoritative articles of Mr. William L. Stevenson in each issue of

The Collectors' Journal,

besides the snappy news notes and distinctly READABLE articles. Keep abreast of the times by reading it regularly. A sample for 5c. The May issue illustrating the secret mark on the 30c Continental for 10c. A year's subscription for 50c.

H. L. LINDQUIST, Editor,

700 E. 40th St.,

Chicago.

NASSAU BLANK ALBUMS.

The Nassau Album.

A blank, loose leaf album gotten up regardless of expense, in the best possible manner and at the lowest price consistent with the production of a superior article.

This album can be had with either method of fastening, peg type or spring back, bound in maroon or green morocco leather, with protecting sheets of Japan or "glass" paper, the latter especially adapted for the chalky British Colonials. Size of pages, 10 3/8 x 8 5/8 inches.

Price in any quantity \$7.00 net. Additional pages, 8c each.

The Popular Blank Album.

The cheapest blank album on the market, contains 60 pages, 11 1/8 x 8 1/2 inches, linen hinged, quadrille ruled, handsomely bound in green cloth with spring back and the latest patented devices for preventing the leaves from slipping to the bottom when the album is kept in an upright position.

Price\$3.50 net.
Additional pages can be supplied at 3c each.

The Larger Popular Blank Album.

Similar in every respect to our Popular Blank Album above described but containing 50 leaves, 14x10 1/2 inches of heavier quality. This album is especially desirable for complete and reconstructed sheets of stamps.

Price\$3.75 net.
Additional pages can be supplied at 5c each.

PHILATELIC ACCESSORIES.

A full line of these necessary articles always on hand.

Watermark detector, 20c

Compass & divider, \$1.50

TWEEZERS.

Seven different kinds to select from to suit every touch.

| | | | |
|------------------------------------|-----|------------------------------------|-----|
| No. 1, the cheapest | 15c | No. 4, narrow rounded points | 50c |
| No. 2, narrow rounded points | 30c | No. 5, narrow rounded points | 50c |
| No. 3, broad square points | 35c | No. 6, broad rounded points | 50c |
| | | No. 7, broad rounded points | 50c |

These are all highly finished, nickel plated with rough finger grip and smooth points. Leather sheath for any of the above supplied at 5c.

Hinges.

The Nassau hinge, a perfect peelable hinge on thin white transparent paper, pure and tasteless gum. In envelopes of 1,00010c.
In tin boxes with utility watermark detector on the bottom15c

Add 5c postage for accessories ordered by mail.

NASSAU STAMP CO.

118 Nassau St.

New York, N. Y.

80 1111 1111

